

REV	ECO	REV BY	DATE	APPD	DATE
E	0025584	J.AGUILERA	04-26-2012	R.RASCON	04-26-2012

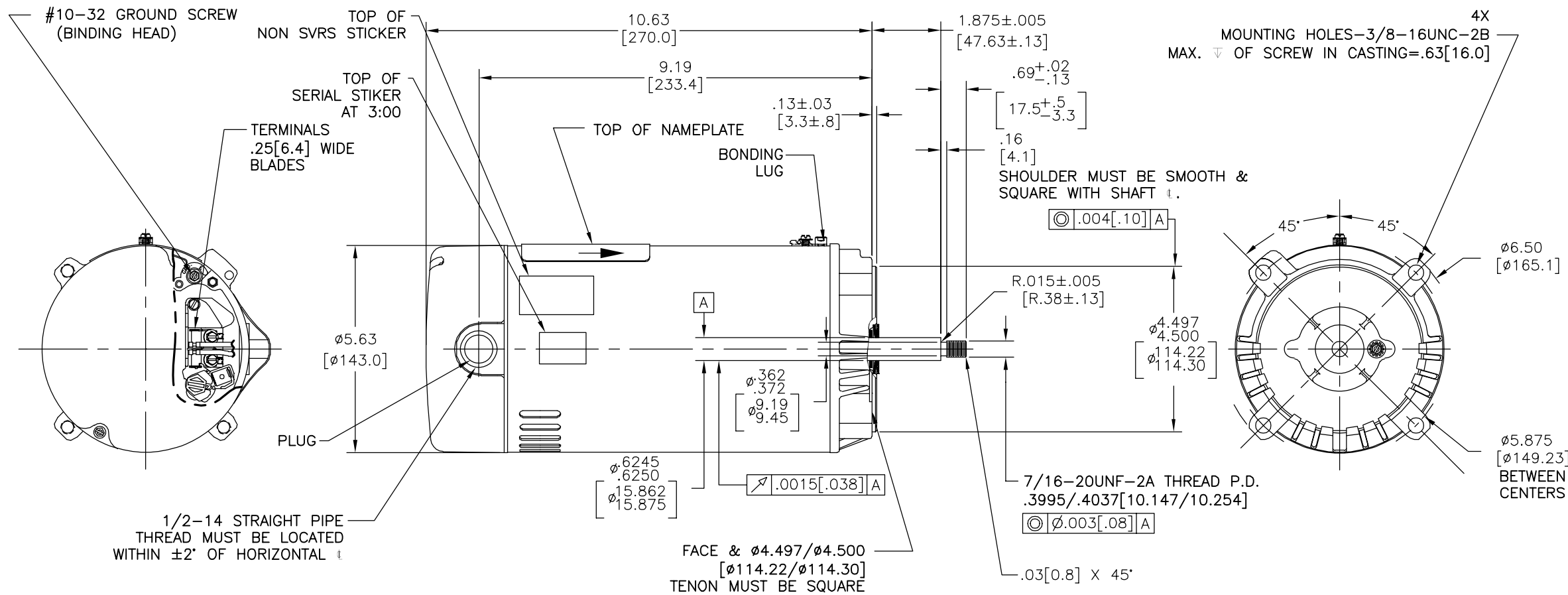

NAMEPLATE DATA	EXTERNAL CONNECTION DIAGRAM	NOTES
MODEL: C48J2N131C1C CUST PN: UST1072 HP: 3/4 SF: 1.0 ROT: CCWPE RPM: 3450 TYPE: UAC CODE: H FORM: FRAME: 56J VOLTS: 115/230 AMPS: MAX AMPS: 10.6/5.3 SF AMPS: - PH: 1 HZ: 60 INS: B AMB: 50 DUTY: CONT ENCLOSURE: ODP THERM. PROT.	<p>GRD GREEN (GROUND)</p> <p>HIGH VOLTAGE SHOWN. ROTATE DIAL CCW TO 115 FOR LOW VOLTAGE.</p> <p>USE COPPER CONDUCTORS ONLY. INSTALL MOTOR WITH VENTS DOWN.</p> <p>ACCEPTABLE FOR FIELD WIRING</p>	<ol style="list-style-type: none"> 1. FINISH PAINT TO BE SATIN BLACK. 2. .44[11.1] WRENCH FLATS ON SHAFT-FOR ACCESS TO THIS WRENCH FLAT REMOVE END COVER. 3. STAINLESS STEEL SHAFT EXT. 4. LIMITS ON AMPLITUDE OF VIBRATION MEASURED AT BEARING HOUSING = .001[.03]. 5. DUAL VOLTAGE MOTORS ARE TO BE CONNECTED FOR HIGHER VOLTAGE. QUICK VOLTAGE CHANGE PLUG INCLUDED ON THE TERMINAL BOARD.

PERFORMANCE CURVE	APPROVED SAMPLE	GEOMETRIC CHARACTERISTICS & SYMBOLS □ FLATNESS - STRAIGHTNESS ∟ ANGULARITY ⊥ PERPENDICULARITY (SQUARENESS) // PARALLELISM ○ ROUNDNESS (CIRCULARITY) ∅ CYLINDRICITY △ PROFILE OF ANY SURFACE ∩ PROFILE OF ANY LINE ↑ RUNOUT ⊕ TRUE POSITION ⊙ CONCENTRICITY = SYMMETRY	UNLESS OTHERWISE SPECIFIED DIM. TOLERANCES ARE AS FOLLOWS: INCH X XX XXX XXXX ±.1 ±.02 ±.005 ±.0005 mm ±0.5 ±0.13 ±0.013 ANG. ±.50 DEG REMOVE BURRS & BREAK SHARP EDGES: INCH .003-.015 mm 0.1-0.4 CORNER FILLETS TO: INCH .020 mm 0.5 MACHINE SURFACES: INCH 125 mm 3.2	DR BY: Richard.Pan	REGAL-BELOIT CORPORATION DESCRIPTION: MODEL-PFHP-48FR OUTLINE SIZE: C DWG NO: UST1072 SCALE: NONE SHEET: 1
C48J2W34	CSA			APPD: THIRD ANGLE PROJECTION EDS DATE 11-11-2011 FORMAT REV G CONFIDENTIAL: THIS DRAWING AND ITS INFORMATION ARE THE EXCLUSIVE AND CONFIDENTIAL PROPERTY OF REGAL-BELOIT CORPORATION AND ARE NOT TO BE DISCLOSED, DUPLICATED, DISTRIBUTED OR OTHERWISE USED WITHOUT THE WRITTEN CONSENT OF REGAL-BELOIT CORPORATION. -ALL RIGHTS RESERVED.	
UL COMPONENT	FILE#	CCN#	FILE#	GUIDE#	
E25022	XEWR2	LR43341	4211-01		
CUSTOMER	DISTRIBUTION SERVICES				

4

3

2

1

REVISION:	ECO	REVISADO POR:	FECHA:	APROBADO POR:	FECHA:
E	0025584	J.AGUILERA	04-26-2012	R.RASCON	04-26-2012

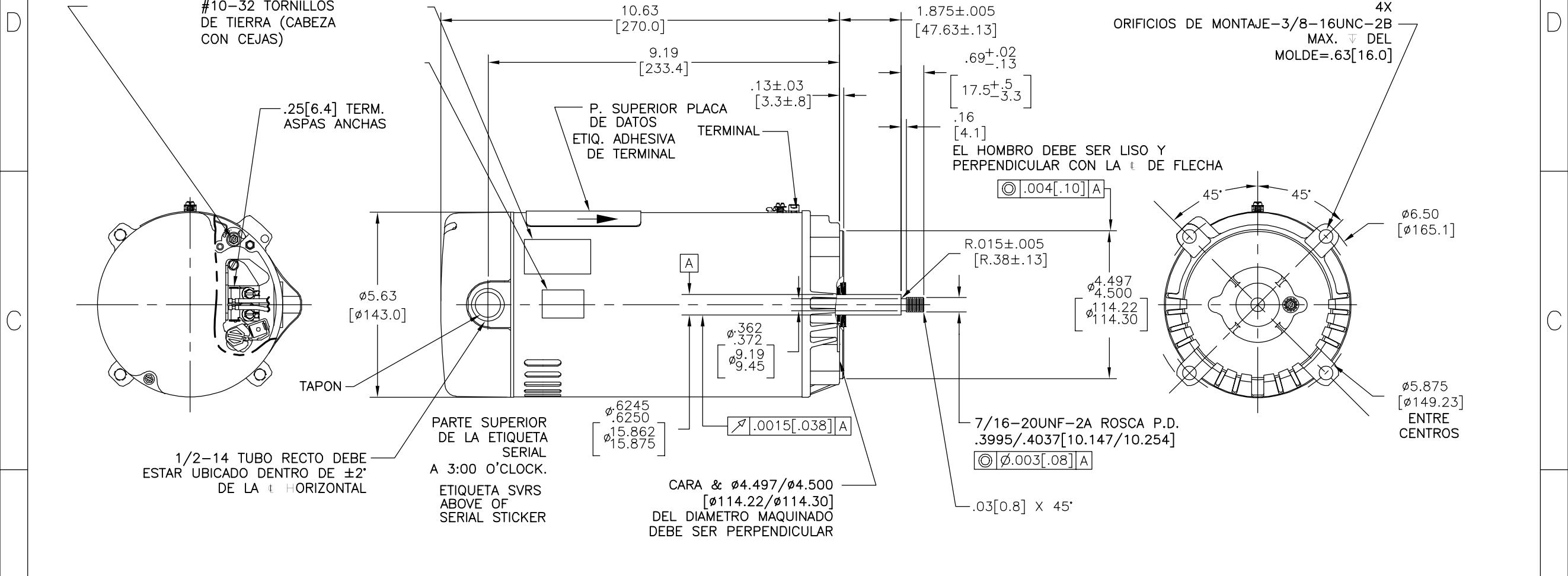

NAMEPLATE DATA	EXTERNAL CONNECTION DIAGRAM	NOTES
MODEL: C48J2N131C1C CUST PN: UST1072 HP: 3/4 SF: 1.0 ROT: CCWPE RPM: 3450 TYPE: UAC CODE: H FORM: FRAME: 56J VOLTS: 115/230 AMPS: MAX AMPS: 10.6/5.3 SF AMPS: - PH: 1 HZ: 60 INS: B AMB: 50 DUTY: CONT ENCLOSURE: ODP THERM. PROT.		<ol style="list-style-type: none"> 1. PINTURA DE ACABADO ES EL SATIN NEGRO. 2. PLANOS DE .44[11.1] PARA LLAVE EN LA PARA TENER ACCESO A ESTE PLANO DE LLAVE RETIRAR CUBIERTA. 3. EXTENSION DE FELCHA DE ACERO INOXIDABLE. 4. LIMITES DE AMPLITUD DE MEDICION DE VIBRACION EN LA CAVIDAD DEL BALERO = .001[.03]. 5. MOTORES DE DOBLE VOLTAJE SE VAN A CONECTAR PARA ALTO VOLTAJE. CLAVIJA PARA CAMBIO RAPIDO DE VOLTAJE INCLUIDA EN LA TABLILLA DE CONEXIONES. 6. ATENUADOR DE SOPORTE ESTA EMPACADO CON CADA MOTOR. 7. ENSAMBLE DE REFERENCIA DEL MOTOR: 617158-008

PERFORMANCE CURVE	APPROVED SAMPLE	CARACTERISTICAS DE GEOMETRIA Y SIMBOLOS	A MENOS QUE SE ESPECIFIQUE DE OTRA MANERA, LAS TOLERANCIAS DE LAS DIMS; SON LAS SIGUIENTES:	DIBUJADO POR: Richard.Pan	FECHA EDS: 11-11-2011
C48J2W34	CSA	□ PLANICIDAD - RECTITUD < ANGULARIDAD ⊥ PERPENDICULARIDAD (A ESQUADRA) // PARALELISMO ○ REDONDEZ (CIRCULARIDAD) ∅ CILINDRICIDAD △ PERFIL DE CUALQUIER SUPERFICIE ∩ PERFIL DE CUALQUIER LINEA † VARIACION ⊕ POSICION REAL ⊙ CONCENTRICIDAD = SIMETRIA	PULG ±.1 ±.02 ±.005 ±.0005 mm ±0.5 ±0.13 ±0.013 ANG. ±.50 GRADOS ELIMINAR REBABAS Y ORILLAS FILOSAS DEL BORDE. PULG .003-.015 mm 0.1-0.4 FILETEAR ESQUINA: PULG .020 mm 0.5 MAQUINAR SUPERFICIES PULG 125 mm 3.2	APROBADO POR:	REV. FORMATO: G
UL COMPONENT	CSA	ASME Y14.5M 1994	DIMS METRICAS MOSTRADAS [PARENTESIS]	TERCER ANGULO DE PROYECCION	CONFIDENCIAL: ESTE DIBUJO Y SU INFORMACION SON PROPIEDAD DE USO EXCLUSIVO Y CONFIDENCIAL DE REGAL-BELOIT CORPORATION. Y NO DEBERAN SER REVELADOS, DUPLICADOS, DISTRIBUIDOS O USARSE DE OTRA MANERA SIN EL CONSENTIMIENTO ESCRITO DE REGAL-BELOIT CORPORATION. -TODOS LOS DERECHOS RESERVADOS.
FILE#	CCN#	FILE#	GUIDE#	DESCRIPCION:	MODEL-PFHP-48FR OUTLINE
E25022	XEWR2	LR43341	4211-01	TAMAÑO:	C
CUSTOMER	DISTRIBUTION SERVICES			NUMERO DE DIBUJO:	UST1072
				ESCALA: NONE	HOJA: 1

4

3

2

1

版本	ECO	编制	日期	批准	日期
E	0025584	J.AGUILERA	04-26-2012	R.RASCON	04-26-2012

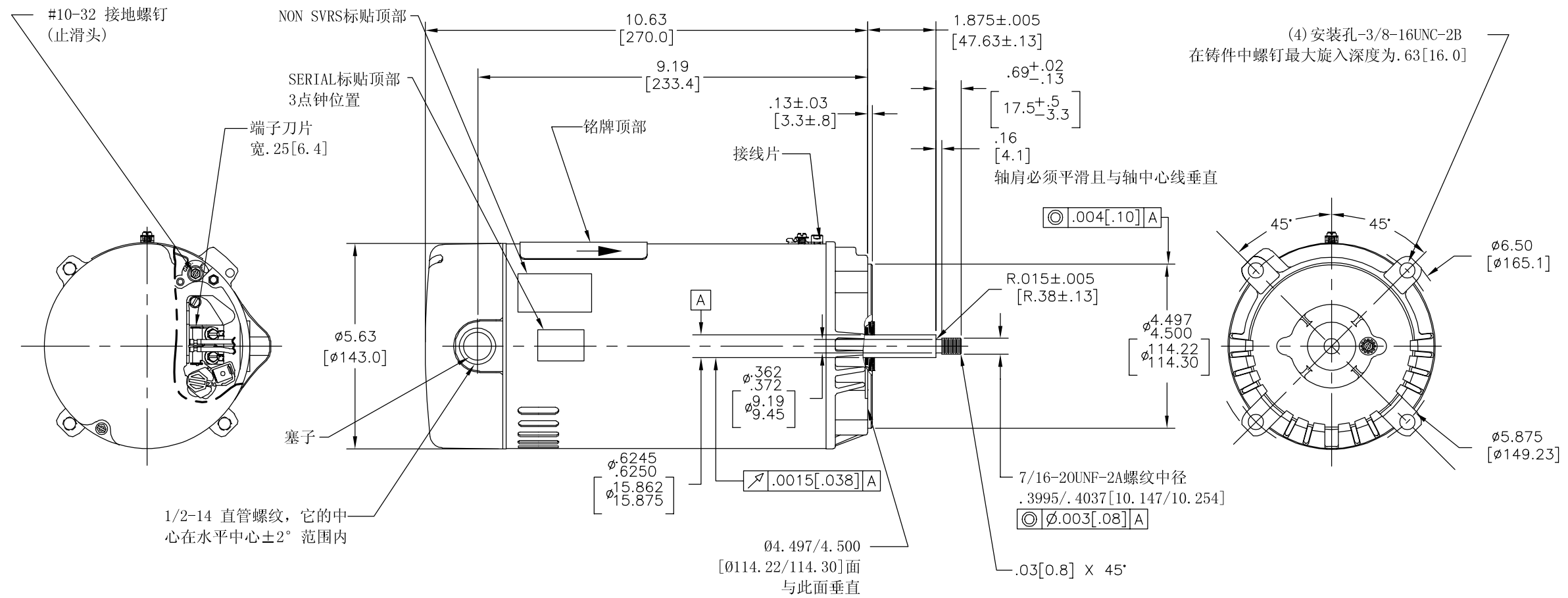

NAMEPLATE DATA	EXTERNAL CONNECTION DIAGRAM	NOTES
MODEL: C48J2N131C1C CUST PN: UST1072 HP: 3/4 SF: 1.0 ROT: CCWPE RPM: 3450 TYPE: UAC CODE: H FORM: FRAME: 56J VOLTS: 115/230 AMPS: MAX AMPS: 10.6/5.3 SF AMPS: - PH: 1 HZ: 60 INS: B AMB: 50 DUTY: CONT ENCLOSURE: ODP THERM. PROT.		<ol style="list-style-type: none"> 表面处理喷黑漆。 移去后盖可见.44[11.2]的扁身。 不锈钢轴伸。 在轴承室测量的振动值最大振幅=.001[.03]。 电机接高电压。 端子板上包括快速改变电压的插销。

PERFORMANCE CURVE	APPROVED SAMPLE		
C48J2W34			
UL COMPONENT	CSA		
FILE#	CCN#	FILE#	GUIDE#
E25022	XEWR2	LR43341	4211-01
CUSTOMER	DISTRIBUTION SERVICES		

形位公差
 □ 平面度
 — 直线度
 < 倾斜度
 ⊥ 垂直度
 // 平行度
 ○ 圆度
 ⊙ 圆柱度
 △ 面轮廓度
 ∩ 线轮廓度
 ↗ 圆跳动
 ⊕ 位置度
 ⊗ 同轴度
 ≡ 对称度

ASME Y14.5M 1994

除另有注明
尺寸公差如下:

英寸	X	XX	XXX	XXXX
毫米	±.1	±.02	±.005	±.0005
角度	±.50			

清理毛刺和尖棱
英寸 .003-.015 毫米 0.1-0.4

内圆角
英寸 .020 毫米 0.5

表面粗糙度
英制 125 米制 3.2

米制尺寸显示在 []

绘图: Richard.Pan

批准:

第三角投影

图纸格式发布日期 11-11-2011
图纸格式版本 G

机密: 本图纸及相关信息所有权归REGAL-BELOIT CORPORATION. 未经REGAL-BELOIT CORPORATION书面授权, 不得泄露、复制、传播或作其他用途。一版权所有

REGAL-BELOIT CORPORATION

名称: MODEL-PFHP-48FR OUTLINE

图幅: C 图号: UST1072

比例: NONE 页号: 1