

Clean & Clear™ Filter System Owner's Manual

**IMPORTANT SAFETY INSTRUCTIONS
READ AND FOLLOW ALL INSTRUCTIONS
SAVE THESE INSTRUCTIONS**

Table of Contents

SECTION I.	PUMP SAFETY INSTRUCTIONS	2
SECTION II.	HOW YOUR FILTER WORKS	2
SECTION III.	CHECK VALVE INSTALLATION INSTRUCTIONS	3
SECTION IV.	INSTALLATION	4
SECTION V.	INITIAL START-UP AND RESTART INSTRUCTIONS.	6
SECTION VI.	CLEANING THE FILTER	6
SECTION VII.	WINTERIZING THE FILTER	8
SECTION VIII.	CLEANING THE HIGH FLOW MANUAL AIR RELIEF VALVE	8
SECTION IX.	TROUBLE SHOOTING	9
SECTION X.	PUMP INSTRUCTIONS	9
SECTION XI.	TECHNICAL DATA	11
A.	FILTER AND TANK	11
B.	MAXIM PUMP	12
C.	DYNAMO PUMP	13

Important Notice



Attention Installer. This manual contains important information about the installation, operation and safe use of this product. This information should be given to the owner/operator of this equipment.

⚠ WARNING

Before installing this product, read and follow all warning notices and instructions accompanying this filter. Failure to follow safety warnings and instructions can result in severe injury, death, or property damage. Call (800) 831-7133 for additional free copies of these instructions.

SECTION I. PUMP SAFETY INSTRUCTIONS

When installing and using this electrical equipment, basic safety precautions should always be followed, including the following:

1. READ AND FOLLOW ALL INSTRUCTIONS.
2. WARNING - To reduce the risk of injury, do not permit children to use this product unless they are closely supervised at all times.
3. WARNING - Risk of Electrical Shock. Connect only to a grounding type receptacle protected by a ground-fault circuit-interrupter (GFCI). Contact a qualified electrician if you cannot verify that the receptacle is protected by a GFCI.
4. Do not bury the electrical cord. Locate the cord to minimize the abuse from lawn mowers, hedge trimmers, and other equipment.
5. WARNING - To reduce the risk of electrical shock, replace damaged cord immediately.
6. WARNING - To reduce the risk of electrical shock, do not use an extension cord to connect unit to electric supply; provide a properly located outlet.
7. CAUTION - For continued protection against possible electrical shock, this unit is to be mounted to the base in accordance with the installation instructions.
8. SAVE THESE INSTRUCTIONS.

SECTION II. HOW YOUR FILTER WORKS

 WARNING	
	To reduce the risk of electrical shock, Only connect to a GFCI protected receptacle. Failure to do so could result in an electrical shock to pool users, installers, or others which can result in serious personal injury or death.

Your cartridge filter is designed to produce clear, sparkling water and operate for years with a minimum of maintenance when installed, operated and maintained in accordance with these instructions.

Your filter uses a cartridge element to remove dirt particles from the water. Dirt is collected in the filter by the cartridge element as water flows through the filter. Water enters the filter through the filter inlet port and is distributed evenly through the cartridge element. The dirt is removed by the cartridge fabric and the clean water flows through the filter outlet port and is returned to the pool through the piping or hoses.

After a period of time, dirt will accumulate in the filter causing a resistance to the flow of water through the filter. This resistance results in a diminished flow of water and a rise in the filter pressure. Eventually the filter will have removed so much dirt and the filter pressure risen to such a point that it will be necessary to clean your filter, see SECTION VI. CLEANING FILTER.

The filter's function is to remove suspended matter from the water and does not sanitize the water. For sparkling clear water, the water must be sanitized as well as balanced. Pool chemistry is a specialized area, and you should consult your local pool service specialist for specific details. In general, proper pool sanitation requires a free chlorine level of 1 to 2 PPM and a PH range of 7.2 to 7.6.

WARNING

Failure to operate your filter system or inadequate filtration can cause poor water clarity obstructing visibility in your pool. Poor water clarity may obscure objects in the water which while swimming and diving could cause severe personal injury and death. Never swim in a pool with poor water clarity.

SECTION III. CHECK VALVE INSTALLATION INSTRUCTIONS

WARNING



THIS FILTER OPERATES UNDER HIGH PRESSURE. WHEN ANY PART OF THE CIRCULATING SYSTEM (e.g., LOCK RING, PUMP, FILTER, VALVES, ETC.) IS SERVICED, AIR CAN ENTER THE SYSTEM AND BECOME PRESSURIZED. PRESSURIZED AIR CAN CAUSE THE LID TO BE BLOWN OFF WHICH CAN RESULT IN SEVERE INJURY, DEATH, OR PROPERTY DAMAGE. TO AVOID THIS POTENTIAL HAZARD, FOLLOW THESE INSTRUCTIONS.

1. BEFORE REPOSITIONING VALVES AND BEFORE BEGINNING THE ASSEMBLY, DISASSEMBLY, OR ADJUSTMENT OF THE LOCK RING OR ANY OTHER SERVICE OF THE CIRCULATING SYSTEM: (A) TURN THE PUMP OFF AND SHUT OFF ANY AUTOMATIC CONTROLS TO ENSURE THE SYSTEM IS NOT INADVERTENTLY STARTED DURING THE SERVICING; (B) OPEN AIR RELIEF VALVE; (C) WAIT UNTIL ALL PRESSURE IS RELIEVED.
2. WHENEVER INSTALLING THE FILTER LOCK RING FOLLOW THE CLEANING FILTER INSTRUCTIONS EXACTLY.
3. ONCE SERVICE ON THE CIRCULATING SYSTEM IS COMPLETE FOLLOW INITIAL START SYSTEM RESTART INSTRUCTIONS EXACTLY.
4. MAINTAIN CIRCULATION SYSTEM PROPERLY. REPLACE WORN OR DAMAGED PARTS IMMEDIATELY (e.g., lock ring, pressure gauge, relief valve, O-rings, etc.).
5. BE SURE THAT THE FILTER IS PROPERLY MOUNTED AND POSITIONED ACCORDING TO INSTRUCTIONS PROVIDED.

A. INSTALLATION

1. Turn the pump off, shut off any automatic controls to assure that the system is not inadvertently started during servicing.
2. Open the High Flow™ manual air relief valve.
3. Plug the suction line by inserting a rag into the skimmer port, or if equipped with a valve close it at this time to prevent water from siphoning from the pool during servicing.
4. If possible, plug the return line to prevent siphoning. If this can not be done, disconnect the union fitting from the outlet port of the filter and quickly place the return hose into the pool.
5. Remove the drain cap to empty the water from the filter.

6. Insert the Check Valve into the outlet port approximately 3/4" to 1" deep making sure the rubber diaphragm facing outward (towards you), see Diagram 1.
7. Reconnect the return hose to the outlet port and tighten the union fitting.
8. Replace the drain cap.
9. Remove the rag from the skimmer or open the valve on the suction line.
10. If the return line was plugged, unplug it at this time.
11. With the High Flow™ manual air relief valve in the open position, start the filter pump, after a steady stream of water appears close the High Flow™ manual air relief valve.
12. Your system is now in operating order.

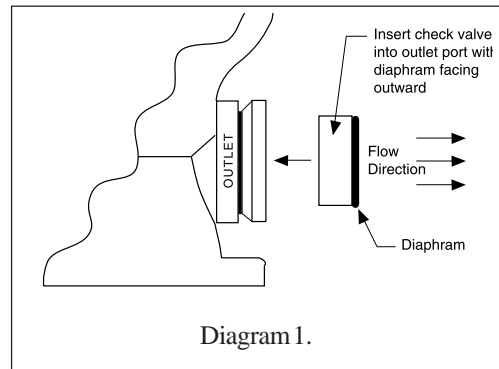

SECTION IV. INSTALLATION

To install this filter system, you will need the following simple tools - a screwdriver, pliers, and wrench.

1. Carefully remove the equipment from the carton and check for any evidence of damage due to rough handling or shipping. If any of the equipment is damaged, immediately notify the organization where the equipment was purchased.
2. Position a tee-nut on the boss underneath the skid base. Screw a bolt with washer into the tee-nut from the top of the base. Continue screwing the bolt into the tee-nut until the tee-nut is flush with the boss. Unscrew the bolt. Repeat procedure for the remaining bosses.
3. This filter should be mounted on a level concrete slab, preferably concrete poured in a form or on a platform constructed of concrete block or brick.
4. Depending upon how your skimmer is positioned in relationship to the return fitting, see Diagram 3, either right or left of the skimmer, position the mounting base accordingly; see Diagram 3. Position the filter tank on the mounting base so the filter **inlet** port is oriented toward the pump similar to Diagram 2. Secure the filter to the mounting base using two bolt fasteners. Place the pump on the mounting base; see Diagram 2. Loosely attach the pump connector, see Detail A, to the pump and filter. This will align the pump to the correct set of mounting holes. Secure the pump to the base using two bolt fasteners. Tighten the union fittings on the plumbing connector by hand until tight. If water leakage occurs at these connections, adjust connections with a wrench making sure not to exceed 1/4 of a turn.

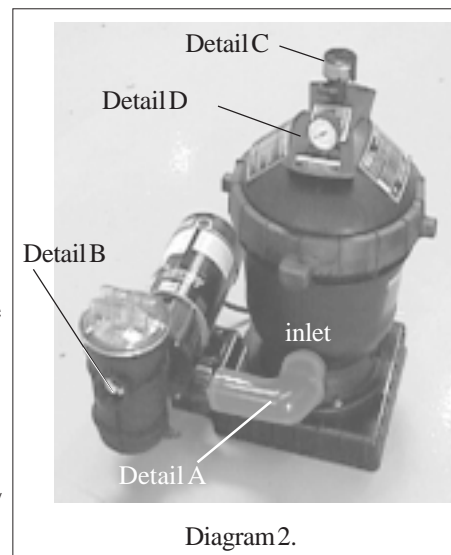

5. Do not mount electrical controls (on/off switches, timer, etc.) over the filter. You need to be able to stand clear of the filter when starting the pump.
6. Attach the hair and lint pot to the front of the pump. This is an O-ring seal fitting that requires hand tightening only. (OVER TIGHTENING CAN RESULT IN DAMAGE TO THE O-RING SEAL)
7. Install the threaded fitting, see Diagram 3 – Figure 1, into the suction port of the pump. This is an O-ring seal fitting that requires hand tightening only. (OVER TIGHTENING CAN RESULT IN DAMAGE TO THE O-RING SEAL)
8. Install the threaded return fitting into the filter outlet port, see Diagram 3 – Figure 2, making sure that the O-ring is in place in the filter body. Tighten this connection by hand until tight. If water leakage occurs at this connection after installation, adjust connection with a wrench making sure not to exceed 1/4 of a turn. (OVER TIGHTENING CAN RESULT IN DAMAGE TO THE FILTER)

9. Connect black hoses to the equipment and the pool with the clamps provided.
 - a. Connect the skimmer suction port from the pool to the pump inlet.
 - b. Connect the filter outlet port to the return fitting of the pool, see Figure 1.
 - c. Install the High Flow™ air relief valve, see Diagram 2 – Detail C, into the top of the filter tank lid. This is an O-ring seal that requires hand tightening only.
 - d. Install the pressure gauge, see Diagram 2 – Detail D, using the Teflon tape provided. Wrap the threads of the pressure gauge with three layers. Install the gauge into the top of the filter tank until tight.
10. Never install a pump in this system that exceeds the maximum pressure of this filter, see data label.

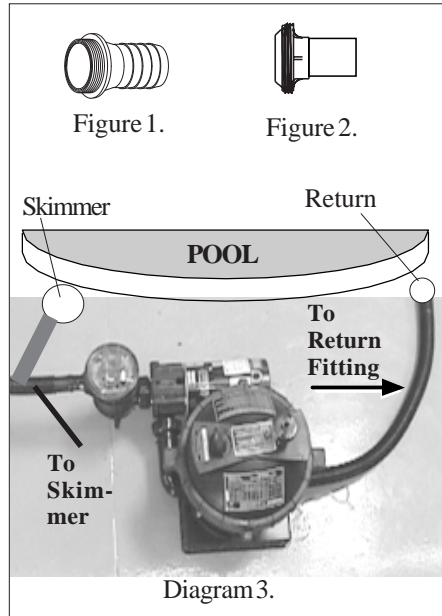

11. If using the optional **Chlorinator Base**, knockout the two slots on the system base with a hammer and screwdriver.
12. Slide the two tabs on the Chlorinator Base into the slots on the system base; see Diagram 4.

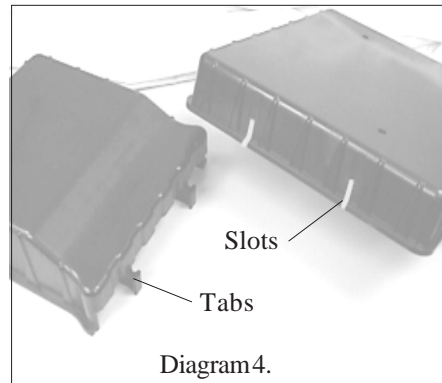

SECTION V. INITIAL START-UP AND RESTART INSTRUCTIONS.

1. Be sure all connections have been made and are secure.
2. Make sure the hair and lint pot of the pump is filled with water. (FAILURE TO FILL THE HAIR AND LINT POT WITH WATER WILL RESULT IN DAMAGE TO THE PUMP AND PUMP SEAL).
3. **OPEN THE HIGH FLOW MANUAL AIR RELIEF VALVE UNTIL IT SNAPS INTO THE FULL OPEN POSITION (THIS ONLY REQUIRES A 1/4 TURN COUNTERCLOCKWISE).**
4. **STAND CLEAR OF THE FILTER.** Start pump allowing the filter tank to fill with water. Close the high flow air relief valve after a steady stream of water appears.
5. Your filter has now started its filter cycle. You should check that the water is returning to the pool and take note of the operating pressure. My original starting pressure is _____ PSI with the filter clean.
6. Check the system for water leaks. If a leak is found, shut off pump before correcting the leak.

⚠ WARNING	
	This filter operates under high pressure. When any part of the circulating system (e.g., lock ring, pump, filter, valves, etc.) is serviced, air can enter the system and become pressurized. Pressurized air can cause the lid to be blown off which can result in severe injury, death, or property damage.

7. As the filter removes dirt and impurities from the pool water, the accumulation will cause the filter pressure to rise and the flow to diminish. When the pressure gauge reading is 8 to 10 PSI higher than the clean filter reading noted above, it is time to clean the filter's element grids, see SECTION VI. CLEANING THE FILTER, below.

SECTION VI. CLEANING THE FILTER

1. Cleaning frequency will vary from pool to pool and with other factors such as weather conditions, heavy rains, dust pollen, bather load and water chemistry. Check the pressure gauge reading on a regular basis and when the pressure gauge reading increases 8 to 10 PSI over the initial clean filter reading, it is time to clean your CARTRIDGE ELEMENT.
2. Turn the pump off, shut off any automatic controls to assure that the system is not inadvertently started during servicing.
3. Plug the skimmer port with a rag. This will prevent pool water from running out during servicing.
4. Open the filter High Flow™ manual air relief valve, and the filter drain plug.
5. Remove the hair and lint strainer pot lid and clean the basket. Replace the basket and secure the lid.
6. Remove the filter lock ring by depressing the two spring loaded locking blocks and rotating the ring counter clockwise until the ring is free from the filter body.
7. Remove the filter lid using the lifting handles on the lid.

8. Remove the CARTRIDGE ELEMENT assembly from the filter body by using the lifting handles and pulling straight up.
9. Remove the CARTRIDGE ELEMENT from the core assembly by placing your middle fingers into cloth area and using your thumbs on top of the lifting handles and pressing until the CARTRIDGE ELEMENT is loose and freely slides off the center core assembly.
10. Using a garden hose, direct water spray at the CARTRIDGE ELEMENT to dislodge and wash away any accumulated foreign matter and Diatomaceous Earth. Thoroughly clean the elements.
11. Clean and remove debris from the inside of the filter tank.
12. Replace the CARTRIDGE ELEMENT over the center core assembly making sure the end of the element with the wording 'This Side Up' is facing up.
13. Replace the CARTRIDGE ELEMENT into the filter tank body making sure the arrow on the top of the center core is aligned with the filter inlet port. You will be able to feel the assembly drop into and lock into place when in the proper position.
14. Clean any debris from the O-ring at the top of the filter tank. Apply a silicone lubricant to the O-ring. **DO NOT USE A PETROLEUM-BASE LUBRICANT ON THE O-RING.**
Failure to properly clean and lubricate the O-ring may result in water leakage.
15. Replace the filter tank lid making sure it is fully and firmly seated on the tank body.
16. Place the filter lock ring over the filter lid, and turn clockwise until the safety latches click and the lock ring hits the stops on the body.
DO NOT ATTEMPT TO OVER TIGHTEN THE FILTER LOCK RING AFTER THE SAFETY LATCHES HAVE ENGAGED.

⚠ WARNING



If the filter lock ring is damaged, replace it immediately.
This filter operates under high pressure. Replace locking ring if damaged or worn. Failure to replace locking ring can result in the lid separating from the filter which can cause severe injury or death.

17. Replace the drain cap hand tight only.
18. Follow Initial Start Up and System Restart Instructions; see Section V.

⚠ WARNING

Failure to operate your filter system or inadequate filtration can cause poor water clarity obstructing visibility in your pool. Poor water clarity may obscure objects in the water which while swimming and diving could cause severe personal injury and death. Never swim in a pool with poor water clarity.

SECTION VII. WINTERIZING THE FILTER

1. In areas that have freezing winter temperatures, the pool equipment must be winterized to protect it from damage.
2. With the pump turned off, open the High Flow™ manual air relief valve.
3. Remove the drain port cap, and allow the filter to drain completely.
4. Remove the drain port plugs on the pump and allow the pump to drain completely.
5. Drain all appropriate system piping.
6. It is recommended that the pump and filter be covered with a tarpaulin or plastic sheet to inhibit deterioration from the weather.
DO NOT WRAP THE PUMP MOTOR WITH PLASTIC.
7. Your filter system is now winterized.
8. See SECTION V. INITIAL START-UP AND SYSTEM RESTART, when pool is ready to be opened for the season.

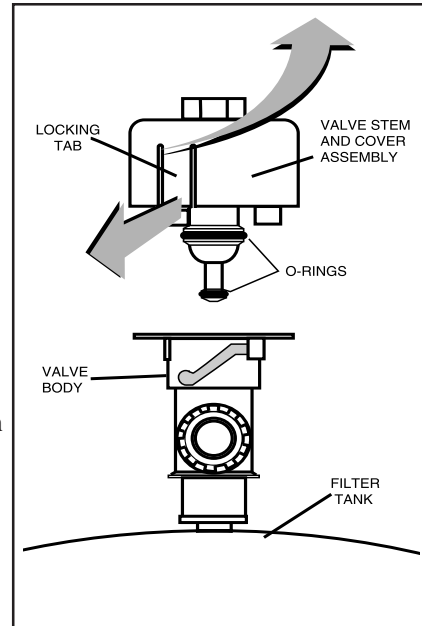

SECTION VIII. CLEANING THE HIGH FLOW MANUAL AIR RELIEF VALVE

1. Turn the pump off and shut off any automatic controls to ensure that the system is not inadvertently started during servicing.
2. **OPEN THE HIGH FLOW MANUAL AIR RELIEF VALVE UNTIL IT SNAPS INTO THE FULL OPEN POSITION, THEN WAIT UNTIL ALL PRESSURE IS RELIEVED.**
3. With the relief valve attached to the filter tank, pull out the locking tabs and remove the valve stem and cover assembly with a counter clockwise and lifting motion, see Figure 4.
4. Clean the debris from the valve stem and body. Verify that the filter tank's air passage is opened by inserting a 5/16" drill bit through the valve body. Verify that the O-rings are in good condition, properly positioned, and lubricated with a silicone base lubricant.
5. Reinstall the valve stem and cover assembly with a downward and clockwise motion until it snaps into position.

SECTION IX. TROUBLESHOOTING

Problem	Cause	Remedy
Pool water not sufficiently clean.	1. Pool chemistry not adequate to inhibit algae growth. 2. Inadequate turnover rate.	Maintain pool chemistry or consult pool service technician. Run system for longer time or consult dealer or pool service technician.
Higher filter pressure.	1. Insufficient cleaning of the filter element. 2. Partially closed valve or restriction.	Clean the filter element (see Cleaning Filter instructions). Open valve or remove obstruction in return line.
Short filter cycles.	1. Insufficient cleaning of filter element. 2. Pool chemistry not adequate to inhibit algae growth. 3. Flow rate too high.	Clean the filter element (see Cleaning Filter instructions). Maintain pool chemistry or consult pool service technician. Restrict flow to capacity of filter.
Return flow to pool diminished, low filter pressure.	1. Obstruction in the pump hair and lint pot. 2. Obstruction in pump. 3. Obstruction in suction line to pump.	Clean basket in strainer. Disassemble and clean pump. Clean skimmer basket. Remove obstruction in lines. Open valves in suction line.

SECTION X. PUMP INSTRUCTIONS

Systems are supplied with either the Maxim or the Dynamo Pump.

1. TO PRIME PUMP - (pump must be off).

Unscrew the lid from the pot and fill the pot with water to level of the suction line. Inspect O-ring, lubricate with silicone lubricant. Screw the lid into the pot, hand tighten, lid shoulder will come to rest on the pot surface. Turn the pump on, priming time will vary depending upon elevation above water level and horizontal distance of suction line. If the filter is installed, open the air relief valve (before turning the pump on) until a steady stream of water comes out, then close the air relief valve. The pump is now primed. If the pump is installed below water level, close the return line prior to filling the hair and lint pot with water. Line must be re-opened before turning the pump on.

 WARNING	
	To reduce the risk of electrical shock, only connect to a GFCI protected receptacle. Failure to do so could result in an electrical shock to pool users, installers, or others which can result in serious personal injury or death.

2. TO CLEAN BASKET - (pump must be off)

Follow the instructions above to prime the pump. After removing the lid, remove the basket and empty the debris. Replace the basket and proceed to fill the pot with water. It is important to visually inspect the basket, through the see through lid, at least once a week. A dirty basket will reduce the efficiency of your system, and can put an abnormal load on the pump which could result in costly repair bills.

3. SHAFT SEAL - (rotary seal). The shaft seal consists of two parts:
 - a. Rotating ceramic seal, press fitted into the impeller.
 - b. A stationary spring loaded seal, press fitted into the rear of the volute.
4. THEELECTRICMOTOR.
 - a. The electric motor should be protected from foreign matter, water splashing, hosing, and the weather. Enclosures should be well ventilated to prevent overheating. If a motor becomes wet, permit it to dry before running it. If a motor has been damaged by water or dirt, the warranty is void.
 - b. The motors used on these pumps are 48 frame through bolt motors. The through bolts are used to secure the volute to the motor. When replacing the motor, mark the end bells and the motor shell to indicate alignment. Remove the four nuts from the through bolts at the shaft end. Place the shaft through the back of the volute and locate the bolts in line with the brass inserts located in the four legs at the rear of the volute. Be sure the end bell and the shell marking line up. Securely fasten the motor to the volute.
 - c. Protect the motor from heat. Provide ample ventilation.

 **CAUTION**

The highly polished and lapped faces of the seal are easily damaged. Handle with care. This centrifugal pump requires little or no service, however the shaft seal will wear with normal use over the years and will require periodic replacement.

 **CAUTION**

DO NOT RUN PUMP DRY. If the pump is run dry, the mechanical seal will be damaged and external leakage will occur. When a seal is damaged, the seal must be replaced.

 **CAUTION**

ALWAYS MAINTAIN PROPER WATER LEVEL IN THE POOL. Water level must be half way up the skimmer opening. A low water level can cause the pump motor to run dry which will damage the mechanical seal and cause external leakage.

SECTION XI. TECHNICAL DATA

A. FILTER AND TANK

Replacement Parts

Find No.	Part No.	Description
1	98209800	High Flow Manual Air Relief Valve
2	53003201	Pressure Gauge
3	178553	Lid, 50/100 Sq./Ft.
3	178561	Lid, 75 Sq./Ft.
4	59052900	Locking Ring Assy.
5	87300400	Body O-ring
6	59016200	Air Bleed Sock Kit
7	59053500	Center Core, 50 Sq./Ft.
7	59053600	Center Core, 75 Sq./Ft.
7	59053700	Center Core, 100 Sq./Ft.
8	59054000	Cartridge Element, 50 Sq./Ft.
8	59054100	Cartridge Element, 75 Sq./Ft.
8	59054200	Cartridge Element, 100 Sq./Ft.
9	178562	Bottom, 50 Sq./Ft.
9	178554	Bottom, 75 Sq./Ft.
9	178563	Bottom, 100 Sq./Ft.
10	86202000	Drain Cap W/ O-ring
11	51005000	O-ring, Drain Cap
12	39104500	Union Nut "C" Clip
13	98212200	Union Nut
14	39102800	Union O-ring
15	178543	Pump Connector
16	39107400	Outlet Connector
17	51516100	Check Valve Kit
18	178540	System Base Assy.
19	178541	Chlorinator Base
20	79304700	Union, Body, for Chlorinator Attach.
	98200700	Bolt
	98317100	T-nut
	39201400	Pump Support

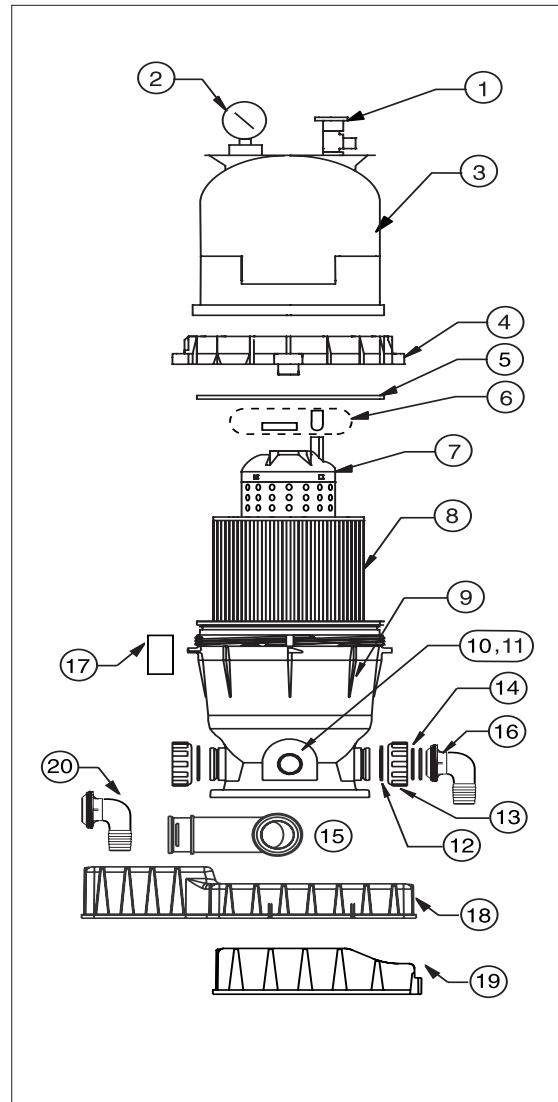

SECTION XI. TECHNICAL DATA (continued)

B. MAXIM PUMP

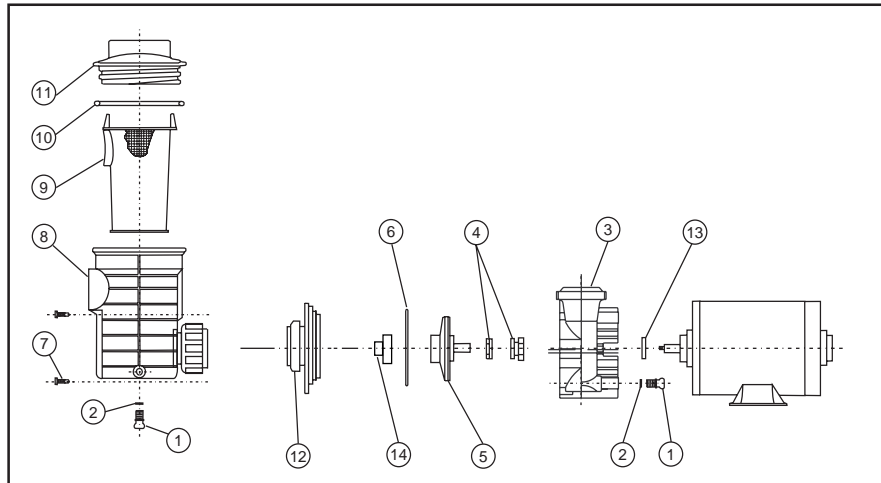

Replacement Parts

Find No.	Part No.	Description
1	98206400	Plug, ¼ in. with O-ring
2	57006500	O-ring
3	39102503	Volute, S Series, vertical
4	39701200	Seal, shaft
5	39104600	Impeller, ½ hp
5	39153100	Impeller, ¾ hp
5	39153200	Impeller, 1 hp
5	39153400	Impeller, 1½ hp
5	39153500	Impeller, 2 hp
5	39153100	Impeller, ½ hp, 50 cycle
5	39153200	Impeller, ¾ hp, 50 cycle
5	39153300	Impeller, 1 hp, 50 cycle
5	39153400	Impeller, 1½ hp, 50 cycle
6	39101500	O-ring, volute
7	98210400	Screw, faceplate, 8-32 x 5/8 in., S Series

Find No.	Part No.	Description
	98215000	No.10 lock washer, internal star
	98215200	Nut, hex, 10-24 Maxim pump
8	39106800	Pot, Union Nut, face plate, wear ring assy.
9	39101200	Basket
10	39101900	O-ring
11	39101100	Lid, clear
11	39101199	Lid, baquacil resistant
12	39502500	Face plate side
13	39102100	Slinger
14	39701800	Weir ring
	39102300	Body, Swivel Union
	39102400	Nut, Swivel Union

SECTION XI. TECHNICAL DATA, (continued)

C. DYNAMO PUMP

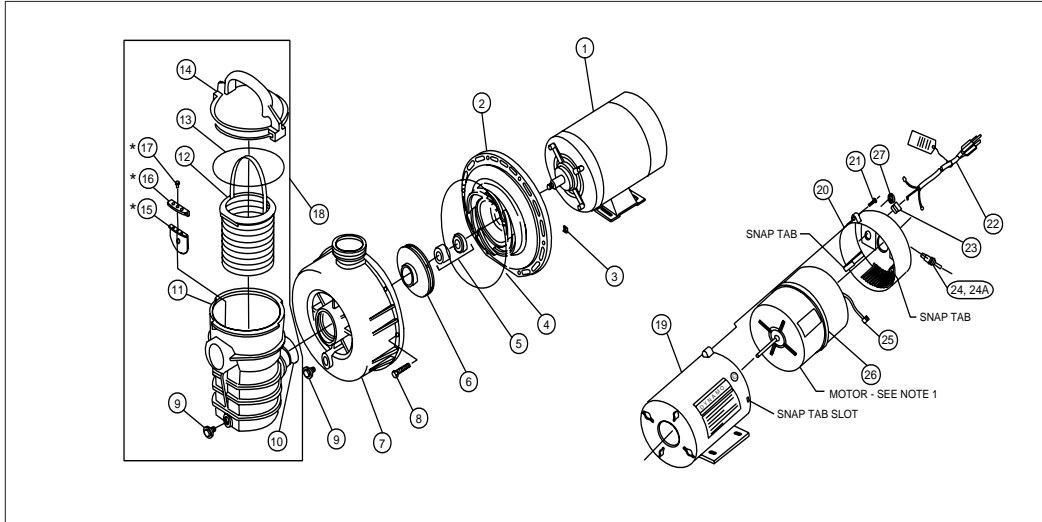

Replacement Parts

Find No.	Part No.	Description	Find No.	Part No.	Description
Motors					
1	35-6471	¾A std. 48 frame thru-bl 115 only	6	35-3002	Impeller - 1½ hp
1	35-6472	1A std. 48 frame thru-bl 115 only	6	35-4552	Impeller - ¾ hp
1	35-6469	1½A std. 48 frame thru-bl 115/230	6	35-5122	Impeller 1, 1½ HP
1	35-6481	¾ 2 spd std. 48 frame thru-bl 115 only	7	35-4630	Housing, body
1	35-6551	1hp 2 spd std. 48 frame thru-bl 115 only 23 lbs.	8	35-4541	Screw 10-24-1½ in. slotted hex, 6 req.
1	35-6486	1½ 2 spd std. 48 frame thru-bl 115 only	9	15-4481	Plug - ¼ in. drain, 2 req.
1	35-6438	¾ std. 48 frame thru-bl 115 only	10	27-3062	O-ring
1	35-6439	1 std. 48 frame thru-bl 115 only	11	35-4530	Pot
1	35-6440	1½ std. 48 frame thru-bl 115/230 23 lbs.	12	35-4548	Basket w/handle
1	35-6445	2 std. 48 frame thru-bl 115/230 28 lbs.	13	35-4533	O-ring, lid
1	35-6441	¾ 2 spd std. 48 frame thru-bl 115 only	14	35-4531	Lid - universal
1	35-6442	1 hp 2 spd std. 48 frame thru-bl 115 only	15	35-4547	Valve - check
1	35-6443	1½ 2 spd std. 48 frame thru-bl 230 only	16	35-4538	Bracket - check valve securing
2	35-4632	Diffuser - ¾ hp bracket	17	35-4540	Screw- 6-19 X 3/8 in. (obsolete)
2	35-4633	Diffuser - 1, 1½ hp bracket	18	35-4583	Adaptor, 1½ in. thrd.
3	35-4542	Nut - 10-24 s/s, 6 req.	19	35-2207	Adaptor, 1½ in. quick connect, 2 req.
4	35-4634	O-ring - 3/16 in. bracket diffuser	20	35-2206	Nut, 1½ in. quick connect, 2 req.
5	35-4545	Seal - 5/8 in. Mechanical	21	35-4571	O-ring, 2 req.
			22	35-4103	Pot assy.

(continued on next page)

SECTION XI. TECHNICAL DATA, (continued)

B. DYNAMO PUMP, (continued)

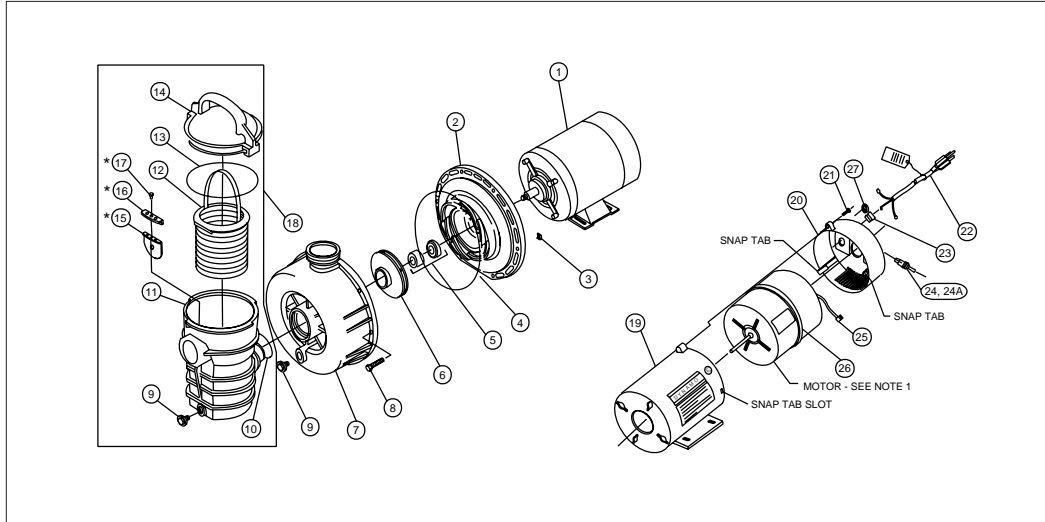

Replacement Parts

Find No.	Part No.	Description
	15-5118	25 ft. cord and plug
	15-5370	25 ft. cord and plug, CSA approved
	15-5234	3 ft. cord with twist lock plug
	35-2245	Strain relief bushing for cords
	15-5297	Photo sensor add-on
23	35-4650	Body - motor enclosure
24	35-4656	Cap - motor enclosure
25	15-4716	Screw - #10 self-tapping
26	15-5371	Cord - 25 ft.
27	35-4657	Bushing
28	15-5187	Switch - on/off TOGGLE
28a	35-6546	Switch - 3 pos. toggle
29	15-5193	Wire - 6 in. jumper
30	35-4658	Insulation - foam strip adhesive backing
31	35-4659	Window - light sensor

SAVE THESE INSTRUCTIONS.

