



# ZODIAC



## Nature<sup>2</sup> Pro G Plus Inground Sanitizer

### Vessel Installation and Operating Manual

**IMPORTANT**

**Pool Owner, save this manual!**

**Builders, leave this manual with the pool owner!**

Thank you for purchasing Nature<sup>2</sup>. This Nature<sup>2</sup> Pro G Plus Inground Vessel provides the housing for the G Inground Replacement Cartridge which is sold separately. Always refer to the owner's manual included with your cartridge for proper start-up procedures and the required low chlorine recipe. Remember, your authorized Zodiac Nature<sup>2</sup> dealer can provide professional advice and service.

**Contents**

	<b>Page</b>
Safety Instructions .....	1
Specifications .....	2
Installation .....	2
Bypass Installation .....	2
Split-Return Installation .....	3
Operation	
Replacing the Nature <sup>2</sup> Cartridge .....	3
Chlorine Tablets .....	3
Filtration/Circulation .....	3
Start Up .....	3
Parts List .....	4
Winterizing Your Pool .....	4
Troubleshooting .....	4
Warranty .....	5

## Safety Instructions - Important Information Please read prior to installation



**Failure to heed the following warnings can result in permanent injury, or drowning.**

**EQUIPMENT UNDER PRESSURE**

- Always turn pump off prior to installing or changing any Nature<sup>2</sup> vessel or cartridge or adding chlorine tablets. Your pump/filter system is operated under pressure and the pressure must be released before you begin work. Please see your pump/filter owner's manual for further instructions.

**PREVENT CHILD DROWNING**

- Do not let anyone, especially small children, sit, step, lean or climb on any equipment installed as part of your pool's operational system. Locate the components of your operational system at least 3 feet from the pool so children cannot use the equipment to access the pool and be injured or drown.

**CHEMICAL USE HAZARD**

- The Pro G Plus is designed to use only Trichloro-S-Triazinetrione tablets - slow dissolving type. NEVER MIX with other types of chlorine or chemicals. Explosion or fire may result.
- Exercise extreme caution when opening or servicing your feeder. Always shut off pump and available valves before opening. Do not inhale any fumes from any chemical feeder or container. Protect your eyes, skin and clothing from chemicals at all times.
- NEVER open chlorinator when pump is running.
- To prevent build up of gas in chlorinator, be sure pool return line valve(s) is kept open - except when opening/servicing unit.
- Always read label and carefully follow chlorine manufacturer's and dealer's recommendations for proper water conditioning and daily chlorine requirements for your particular pool and area.



*Mineral Sanitizers  
for Pools*

The Nature<sup>2</sup> Pool Sanitizer is designed for residential swimming pools only.

Nature<sup>2</sup> is a registered trademark of Zodiac Pool Care, Inc.

© Copyright 2002 Zodiac Pool Care, Inc.

# Specifications

**Capacity:** up to 45,000 gallons (Depending on cartridge size installed.)

**Dimensions:** 18" L x 18" H x 10" D

**Ports:** 2" PVC SKT inlet and outlet

**Weight:** 10 lbs

**Maximum operating pressure:** 45 psi

**Minimum flow rate:** 20 gpm

**Maximum flow rate:** 80 gpm

**Limited warranty:** Vessel - 2 years

**Replacement cartridge:** (sold separately)

**G25** 10,000 to 25,000 gallons

**G35** 25,000 to 35,000 gallons

**G45** 35,000 to 45,000 gallons

**Important:** The proper replacement cartridge model is indicated on the front label of your Pro G Plus.

**Chlorine:** (sold separately)

Use only Trichloro-S- Triazinetrione (Tri-Chlor) Tablets – Slow dissolving type

**Tri-Chlor tablet capacity:** 9 lbs.

## Installation

If you decide to install the Pro G Plus yourself, follow the instructions on this page. The letters in parentheses refer to a diagram on page 4 of this manual.

Under normal pump and filter pressure conditions on inground pool systems, the flow rate to the inlet side of the vessel is 20 to 80 gpm.

**Important:** If your pump system is designed to produce flow rates greater than 80 gpm or if plumbing is greater than 2", then your vessel must be installed in a bypass configuration (see Bypass Installation instructions).

### Installation

**1 Decide where** to install the Pro G Plus. It must be installed:

- on a concrete slab to support the weight of the vessel,
- as the last component on the pool return line **with the Nature<sup>2</sup> side as the inlet and the chlorine side as the outlet.**

**2 Locate the 2" socket inlet and outlet** connections on the vessel.

**Important:** Make sure the pump and filter are turned off prior to Step 3 of the installation process.

**3 Connect the outlet from the filter or heater to the vessel inlet port (E)** with the appropriate Schedule 40 PVC pipe\*; secure the connection with a pipe glue that is compatible with PVC. The Pro G Plus needs to be the last component on the return line.

**Note:** The Pro G Plus must be installed after the heater or heater damage will occur.

**4 Connect the vessel outlet port (K) to the pool's return line** with the same type of PVC pipe\*; secure the connection with the pipe glue.

**Important:** If the Pro G Plus is to be installed below the water level of the pool, precautions must be taken to prevent the pool from draining during installation and during cartridge change or chlorine tablet addition. A check valve should be installed to isolate the vessel for these situations.

**5 Allow sufficient time** for the glue to dry.

**6 Screw on the Locking ring (C)** until it is snug. *Do not overtighten.* Check that all connections are secure.

**Important:** Do not install the Nature<sup>2</sup> Cartridge yet.

**7 Start the pump**, check for leaks and repair any leaks you find.

**8 Refer to your Nature<sup>2</sup> Replacement Cartridge Owners Manual for cartridge start-up procedures.**

\*The Pro G Plus can be reduced to accommodate 1.5" plumbing by using reducing bushings. These bushings will have no effect on the operation of the Pro G Plus.

## Bypass Installation

The Pro G Plus may need to be installed in bypass to the filtration system if plumbing size is greater than 2" diameter or if flow rates are greater than 80 gpm.

If the Pro G Plus is to be installed below the water level of the pool, precautions must be taken to prevent the pool from draining during installation and during cartridge change or chlorine tablet addition. A check valve should be installed to isolate the vessel for these situations.

The Nature<sup>2</sup> vessel is installed on a bypass loop as the last component on the pool return line.

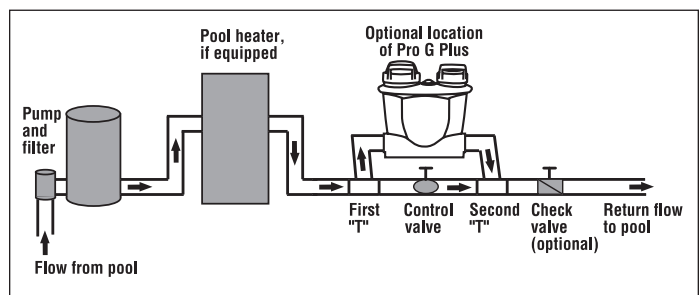

**Note:** Never install Pro G Plus feeder directly into copper plumbing as pipe damage may occur. If you have brass or bronze backwash valves, or other sensitive metallic components, consult your dealer for precautions or recommendations for your particular system.

### To create the bypass:

- 1 Install a "T" in the return line** to allow water to divert to the Pro G Plus. This "T" is then connected to the inlet of the vessel.
- 2 Install a control valve in the return line** after the first "T" and before the second "T".
- 3 Fully open any valves (including the control valve) that were closed.**
- 4 Start the pump** allowing water to pass through the newly plumbed system. The control valve in the return line between the two "T"s will control the flow through the vessel.
- 5 With the control valve open**, read the pressure on the filter gauge.
- 6 Adjust the control valve** until the filter gauge increases by 2-6 psi.
- 7 Check the vessel** for leaks and fix or replace any leaking fittings.
- 8 Follow the start up procedures** included with the Nature<sup>2</sup> replacement cartridge.

# Split-Return Installation

The Pro G Plus must be installed using this split-return installation for use with in-floor cleaning systems or damage to the vessel will occur.

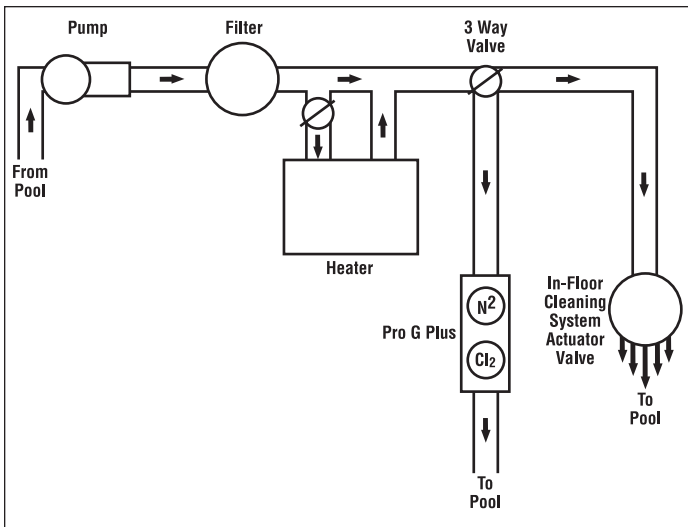

## To create the split-return:

- 1 Install a three-way valve in the return line** to allow water to divert to the Pro G Plus and to the actuator valve. This three-way valve *must be* connected so that water flow can be restricted to either the Pro G Plus or the actuator valve.
- 2 Fully open any valves that were closed.** This includes the three-way valve which should be opened so that there is no restriction to either the Pro G Plus or the actuator valve.
- 3 Start the pump** allowing water to pass through the newly plumbed system. The three-way valve in the return line will control the flow through the vessel and actuator valve.
- 4 With the three-way valve fully open,** determine if the in-floor cleaning heads are operating properly (popping up, rotating, not sluggish, etc.). See actuator valve operating manual for proper operation of the in-floor cleaning system. If so, do not adjust the valve. Proceed to step 6.
- 5 If the in-floor cleaning heads are not operating properly,** adjust the three-way valve by closing off the water flow to the Pro G Plus until the in-floor cleaning heads operate properly.
- 6 Check the vessel** for leaks and fix or replace any leaking fittings.
- 7 Follow the start up procedures** included with the Nature<sup>2</sup> replacement cartridge.

# Operation

## Nature<sup>2</sup> Cartridge

Use the month indicator ring (B) on the top of the unit to identify the date on which the cartridge should be replaced. A cartridge for the Pro G Plus lasts six months.

### To replace the cartridge:

- 1 Shut off your pool's pump and filter.**
- 2 Close any valves between the filter and pool** to prevent draining the pool.
- 3 Unscrew the locking ring (C)** counterclockwise and remove. Lift cap (A) straight off. You may need to gently rock back and forth to remove.
- 4 Remove the old cartridge.**
- 5 Insert the new cartridge.**
- 6 Place cap** so it rests flat on the housing base. **Important:** Make sure O-ring is secure in the groove on the vessel top and not on the underside of the cap (A). Screw locking ring clockwise until it locks: Do not overtighten.
- 7 Rotate the month indicator ring (B)** on the cap top to remind you when to change the cartridge.
- 8 Open any valves that were closed** to isolate the Pro G Plus.
- 9 Restart your pool's pump.** Check for leaks and fix any leaking fittings.
- 10 Follow the start up procedures** included with your Nature<sup>2</sup> replacement cartridge.

## Chlorine Tablets

Your Pro G Plus has a dial type control to regulate the rate of water flow through the chlorine chamber. This large capacity feature, under normal conditions, should provide a minimum of one month chlorination for large pools. By regulating the precision dial on top of the vessel between - and + and the amount of Tri-Chlor tablets you place in the feeder, you can easily adjust the chlorine feed rate that is necessary to maintain the proper chlorine residual for your pool.

**Please make sure you review the chemical use hazard instructions on the first page of this manual when opening the chlorine chamber.** Add the desired amount (up to 9 lbs.) of slow dissolving Tri-Chlor tablets. Screw locking ring (G) clockwise until it locks.

## Filtration/Circulation

### To manage: You need to:

- |                    |  |
|--------------------|--|
| <b>Circulation</b> | Follow the manufacturer's directions for keeping the circulating pump in good working order and <b>operate it at least six hours a day.</b> Consult your Nature <sup>2</sup> dealer for optimum run times. |
| <b>Filtration</b>  | Check the pool's filter periodically and clean it as recommended by the manufacturer.  |

## Start Up

- Before starting up a new Nature<sup>2</sup> cartridge, clean debris and algae out of the pool and pool equipment.

**Important:** *Do not install* the new cartridge until the pool water is clean and chemically balanced.

- Balance pool water before installing Nature<sup>2</sup> cartridge.
  - pH 7.4-7.8
  - Calcium hardness 200-400 ppm
  - Total alkalinity 80-150 ppm

Consult with your Nature<sup>2</sup> Dealer for specific water balance instructions.

## Parts List

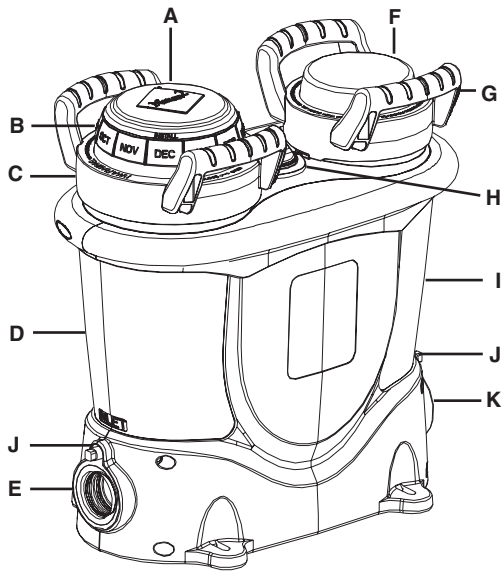

### Pro G Plus

#### Reference Letter Part

A	Nature <sup>2</sup> Cartridge Vessel Cap
B	Month Indicator Ring
C	Nature <sup>2</sup> Locking Ring
D	Nature <sup>2</sup> Cartridge Chamber
E	Inlet Port
F	Chlorine Dispenser Cap
G	Chlorine Locking Ring
H	Chlorine Regulator Dial
I	Chlorine Dispenser
J	Drain Plugs
K	Outlet Port

## Winterizing Your Pool

**If your area requires winterizing your pool and pool equipment, do the following:**

- 1 Remove the Nature<sup>2</sup> cartridge and discard with household trash.
- 2 Carefully remove any remaining chlorine tablets.

**Important:** Review chemical use hazard on page one of this manual before opening chlorine chamber.

- 3 Remove and save the 2 drain plugs (J).
- 4 Rinse out Pro G Plus thoroughly with water.
- 5 If blowing lines clear with air, set chlorine regulator dial to +.
- 6 After completing winterization, loosen locking rings.

### For Spring Start Up:

- 1 Replace the 2 drain plugs.
- 2 Start up your pool as normal.
- 3 After the water has been balanced, insert the new Nature<sup>2</sup> cartridge and chlorine tablets, follow the Nature<sup>2</sup> Start Up instructions.

## Troubleshooting Guide

Consult your Nature<sup>2</sup> Dealer for additional assistance or call 1-888-786-7797.

	Problem	What to look for	Treatment
<b>Equipment</b>	The vessel leaks	A. O-ring missing or improperly seated	Be sure O-ring is secure in the groove on the vessel top below the cap (A or F).
		B. Faulty plumbing	Repair source of leak in plumbing.
	No flow to vessel	Dirty filter (one indication: pressure is 8-10 psi higher than normal)	Clean or backwash filter to reduce pressure

# Limited Warranty

## **NATURE<sup>2</sup> PRO G PLUS VESSEL LIMITED WARRANTY**

The limited warranties contained within this document are the only warranties given with your Nature<sup>2</sup> Pro G Plus Vessel and supercede any prior warranties. **All other warranties, expressed or implied, including the implied warranty of merchantability or the implied warranty of fitness for a particular purpose are hereby disclaimed.** Our sole obligation under this warranty, and the purchaser's sole remedy, is limited to repair or replacement of the Nature<sup>2</sup> Pro G Plus Vessel, or one of its parts. The Nature<sup>2</sup> warranty applies to the original owner only.

## **THE LIMITED WARRANTIES OF THE PRO G PLUS VESSEL:**

The Nature<sup>2</sup> Pro G Plus Vessel you have purchased is warranted to be free of defects and materials and workmanship for a period of two years from the date of purchase. Your warranty registration card must be completed and mailed to Nature<sup>2</sup> to establish your installation date.

## **EXCLUSIONS FROM WARRANTY**

The Nature<sup>2</sup> Pro G Plus Vessel is designed for use on inground pools up to 45,000 gallons, dependent on replacement cartridge size. Installing the Nature<sup>2</sup> Pro G Plus **in-line** with an actuator valve **VOIDS THE WARRANTY**. The Nature<sup>2</sup> Pro G Plus Vessel can not be installed on portable spas. If the unit is used in any other application, the warranty is void, and the purchaser and/or pool owner releases the manufacturer from any and all claims related to the use of Nature<sup>2</sup>.

This warranty does not cover problems arising in whole or in part from purchaser's negligence, misuse or abuse, improper maintenance or storage, accident, improper installation, improper application, failure to follow all appropriate safety precautions, Acts of God, abnormal weather conditions, damage from plants or animals, and improper use of chemicals.

This warranty specifically excludes all incidental or consequential damages, except where state law requires them to be paid. This warranty gives you specific rights. You may have other rights that vary from state to state.

## **TO SUBMIT A CLAIM**

Report claims to Zodiac Pool Care, Inc. by calling 1-888-537-6657. Only the original purchaser may submit a claim under this limited warranty. All claims must be accompanied by an original purchase receipt.



Zodiac Pool Care, Inc.  
2028 NW 25th Avenue  
Pompano Beach, FL 33069  
1-800-YES-PURE  
[www.nature2.com](http://www.nature2.com)