

GOLDLINE VALVE ACTUATOR



Installation Manual

for model
GVA-24

IMPORTANT SAFETY INSTRUCTIONS

When using this electrical equipment, basic safety precautions should always be followed, including the following: Failure to follow instructions may result in injury.

READ AND FOLLOW ALL INSTRUCTIONS

1. Goldline Model GVA-24 must be installed by qualified personnel in compliance with all applicable electrical codes.
2. Disconnect electrical power before servicing unit. Replace all screws and covers before reconnecting unit to electric power.
3. **WARNING:** To reduce the risk of injury, do not permit children to use this product unless they are closely supervised at all times.
4. **CAUTION:** Low voltages are present inside the actuator cover, unless the power supply to the actuator has been shut off or disconnected. Use caution whenever working on the actuator when the cover is removed. **ATTENTION:** We highly recommend having a qualified professional install this product. Failure to do so could result in severe personal injury and/or void your warranty.

EFFECTS OF HYPERTHERMIA

Hyperthermia occurs when the internal temperature of the body reaches a level several degrees above the normal body temperature of 98.6°F. The symptoms of hyperthermia included an increase in the internal temperature of the body, dizziness, lethargy, drowsiness and fainting. The effects of hyperthermia include failure to perceive heat; failure to recognize the need to exit spa or hot tub; unawareness of impending hazard; fetal damage in pregnant women; physical inability to exit the spa or hot tub; and unconsciousness resulting in the danger of drowning. **WARNING -** The use of alcohol, drugs, or medication can greatly increase the risk of fatal hyperthermia.

SAVE THESE INSTRUCTIONS

Description

The GVA-24 Goldline Valve Actuator rotates 2-port and 3 port valves automatically. Use it with the Aqua Logic system or GL-235 Solar Controller to automate pool/spa operation, solar heating, cleaner operation, water features, or a variety of other uses. The industry standard configuration of the GVA-24 means that it is compatible with all major manufacturer's valves and pool automation systems. The unique cam setting feature ensures a quick and easy installation with the precise control of water flow.

Installation

Mounting Options

Three Port Valve

The Model GVA-24 Actuator may be mounted to the valve in four different positions (Fig. 1). Depending on the location of the common port (where water enters valve) and exit port (where water leaves valve), the cam settings may have to be changed. See diagrams/tables on the following pages to determine which configuration matches your system.

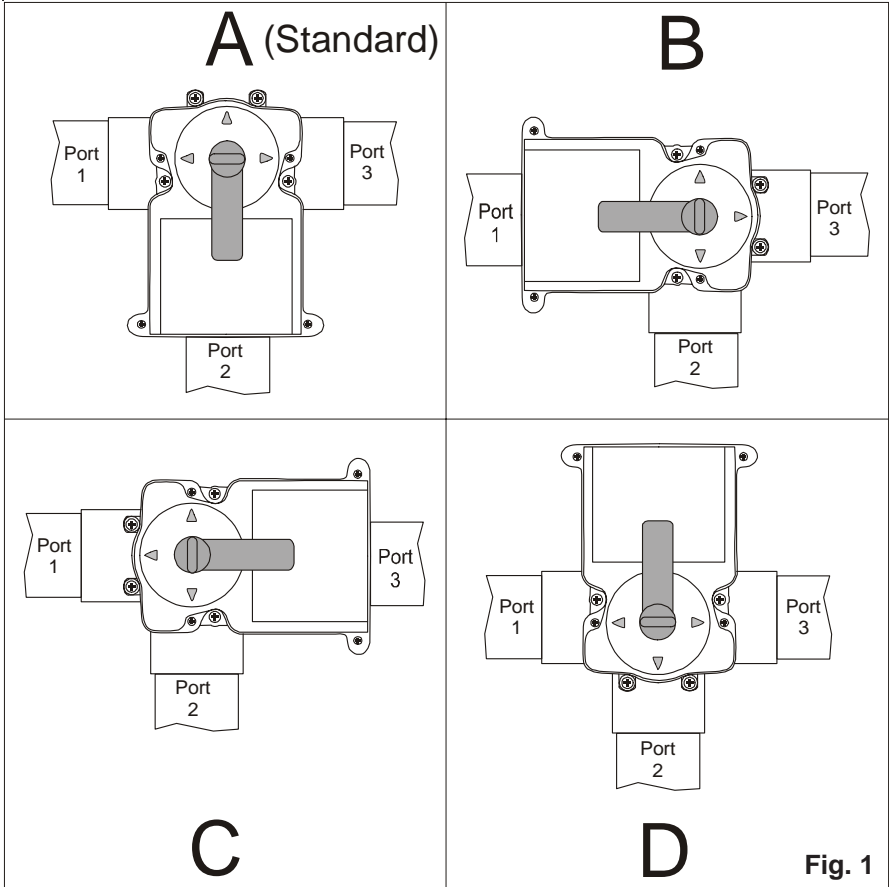

Fig. 1

Using the chart below to determine correct cam setting using standard clock positions. Refer to the "Cam Adjustment" section in this manual to change upper and lower cam positions if necessary.

GVA MOUNTING OPTION	PORT WHERE WATER ENTERS	CAM SETTING		PORT WHERE WATER EXITS	
		LOWER CAM	UPPER CAM	PORT	PORT
A (Standard)	1	6 o'clock	9 o'clock	2	3
	2 (std)	12 o'clock	12 o'clock	1	3
	3	3 o'clock	6 o'clock	1	2
B	1	9 o'clock	12 o'clock	2	3
	2	3 o'clock	3 o'clock	1	3
	3	6 o'clock	9 o'clock	1	2
C	1	3 o'clock	6 o'clock	2	3
	2	9 o'clock	9 o'clock	1	3
	3	12 o'clock	3 o'clock	1	2
D	1	12 o'clock	3 o'clock	2	3
	2	6 o'clock	6 o'clock	1	3
	3	9 o'clock	12 o'clock	1	2

Two Port Valve

The Model GVA-24 Actuator may be mounted to the valve in four different positions. In all cases, the cam settings are the same. Refer to the chart below for cam settings for 2 way valves.

CAM SETTING	
LOWER CAM	UPPER CAM
3 o'clock	6 o'clock

Mounting Instructions

If the valve is plumbed with Port 2 as the common port and the main body of the actuator is mounted over Port 2 (standard mounting), there is no need to adjust the actuator cams.

1. Remove Locking Knob and handle. Set aside for reinstallation later.
2. Remove four (4) screws from the valve. Refer to Fig. 1 (mounting positions) to determine which screws to remove.
3. On the back side of the actuator, align the smallest slot on the actuator shaft with the smallest slot on the valve diverter.
4. With the two shafts engaged rotate the actuator until holes on the actuator align with the screw holes on the cover.
5. Use four (4) ¼-14x1½" long screws (packaged with the actuator) to secure it in place. Do not overtighten - be careful if using a power screwdriver.
6. Place valve handle on actuator shaft and tighten Locking Knob.

Cam Adjustment

1. When changing the cam settings, move toggle switch at bottom of actuator to the OFF (center) position.
2. Unscrew and remove Locking Knob and handle from actuator shaft.
3. Remove the four (4) screws which hold the actuator cover on and remove cover.
4. The upper and lower cam are located on the actuator shaft. Slide the cams off the shaft splines and rotate to the desired position. Refer to the charts on the previous pages to determine the correct cam setting for your installation. Some installations may require settings not found on the chart (partial open, partial close, etc.) All settings are referenced from the small slot on the shaft, which is always 12 o'clock (Fig. 2). The upper cam effects the clockwise position stop point. The lower cam to effects the counterclockwise rotation stop point.

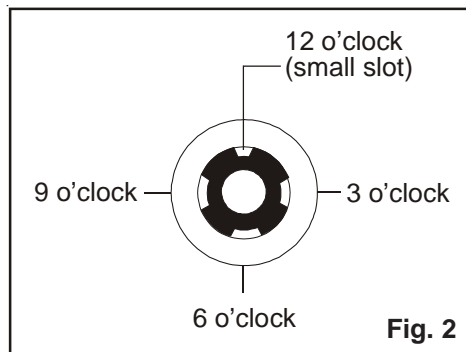

5. The toggle switch on the bottom of the valve actuator can be used to verify if the new adjustment is correct (flip between ON1 and ON2).
6. Replace cover and handle and tighten screws and Locking Knob.
7. Put toggle switch back to ON1 or ON2 position.

Synchronization Instruction

After installation of the actuator(s), they may need to be synchronized. Out of synchronization refers to the condition where one actuator is rotating incorrectly in relation to another actuator. To correct this, simply flip the toggle switch at the bottom of the actuator which is out of synchronization between the ON1 and ON2 position.

Manual Override

In the event of a power failure, you may need to move the valve position manually. Before performing this procedure, turn off pool filtration just in case power resumes. Follow the instructions below for manual override of the GVA-24 actuator.

1. Put the toggle switch in the OFF (center) position.
2. Unscrew the Locking Knob above the handle approximately 4 full turns (Fig. 3).
3. Push down on the Locking Knob. This will disengage the gear train and allow the handle and thus the diverter to be moved in any position.
4. To return the actuator to automatic position, pull up on the handle while turning it clockwise or counterclockwise until you feel the shaft slide up into the gear train. Screw the Locking Knob down until snug.
5. Put the toggle switch back in the ON1 or ON2 position.

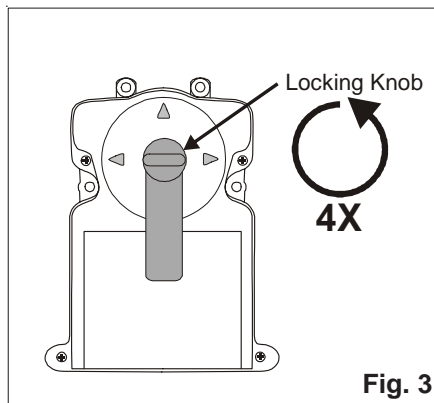

Maintenance

The GVA-24 has two seals which should be lubricated every year. These O-ring seals are located at the top and bottom of the actuator, where the shaft exits the actuator housing. The top O-ring requires the removal of the handle, and the bottom requires that the gear train is disengaged. Follow the procedure below for instructions on how to lubricate the O-ring seals. Before performing this procedure, turn off pool filtration.

1. Put the toggle switch in the OFF (center) position.
2. Remove the actuator from the valve. Remove the Locking Knob and handle.
3. Spread a small amount of Jacks 327 or other silicone based lubricant around the actuator shaft where it enters the cover.
4. Reinstall handle and Locking Knob but only tighten one (1) turn.
5. Push down on the Locking Knob to disengage the gear train. This will allow the handle and the shaft to be moved in any position.
6. Spread a small amount of lubricant around the actuator shaft where it protrudes from the bottom of the actuator enclosure.
7. Turn the handle once around to spread the lubricant.
8. Pull up on the handle, let it click into place and tighten Locking Knob.

Troubleshooting

If you believe your actuator is not operating properly or have questions regarding the operation, call the Goldline Technical Service Dept. from Monday through Friday, 8AM to 8PM EST at 888-921-7665.

1. Actuator handle oscillates.

This condition may happen when the GVA-24 O-ring seals are not lubricated sufficiently. See "Maintenance" section in this manual.

2. Actuator motor works but the valve diverter does not turn.

On a pool/spa combination, the symptom of this problem would be a draining or overflowing spa. This condition will occur if the actuator is in the manual position. To correct this, pull up on the handle while rotating the handle in any direction until it clicks, then tighten the Locking Knob.

3. Actuator motor does not turn

The motor will not turn if the switch is in the OFF position or if there is no power to the actuator. If the switch is in the OFF position, move to ON1 or ON2. To check power to the actuator, measure AC volts between the black (common) and each switch leg (red then white). If there is no AC volts on either leg, check the 24VAC power source.

Limited Warranty—Pool Automation & Chlorination Products 10/1/2004

This warranty statement is applicable to all pool automation and chlorination products manufactured by Goldline Controls, Inc. (Goldline) **on or after October 1, 2004**. See the appropriate warranty statement for other Goldline products or for pool automation and chlorination products produced prior to October 1, 2004.

Aqua Rite/Trol/Logic—Residential pools in USA or Canada:

Goldline warrants Aqua Rite, Aqua Trol, and Aqua Logic products (products with Goldline part numbers starting with AQ-RITE-, AQ-TROL-, AQ-LOGIC-, AQL-P-, AQL-PS-, or AQL-CL-) installed on private, residential swimming pools within the USA or Canada to be free from defects in material or workmanship, under normal use and service for **five years** from date of the initial system installation, provided it is installed in accordance with the Goldline installation instructions and specifications provided with the product. If written proof of the date of the initial system installation is not provided to Goldline, the manufacturing datecode on the Aqua Rite, Aqua Trol, or Aqua Logic electronics unit will be the sole determinant of the date of the initial system installation.

If a product is defective, in workmanship or materials and is removed and returned freight prepaid within three (3) years after the date of the initial system installation, Goldline Controls will, at its option, either repair or replace the defective product and return it freight prepaid. If the defective product is returned freight prepaid to Goldline more than three (3) years but within five (5) years of the date of the initial system installation, Goldline, at its option, will either repair or replace the defective product and will charge sixty percent (60%) of the current list price for such repairs or replacements, plus shipping charges. The costs incurred in removal and/or reinstallation of the product are NOT covered under this warranty.

Aqua Rite/Trol/Logic-- Commercial pools or any pool outside of the USA or Canada:

Goldline warrants Aqua Rite, Aqua Trol, and Aqua Logic products (products with Goldline part numbers starting with AQ-RITE-, AQ-TROL-, AQ-LOGIC-, AQL-P-, AQL-PS-, or AQL-CL-) installed on commercial pools anywhere or any non-private single family residential pool or any pool outside of the USA or Canada to be free from defects in material or workmanship, under normal use and service for **one year** from date of the initial system installation, provided it is installed in accordance with the Goldline installation instructions and specifications provided with the product. If written proof of the date of the initial system installation is not provided to Goldline, the manufacturing datecode on the Aqua Rite, Aqua Trol, or Aqua Logic electronics unit will be the sole determinant of the date of the initial system installation.

If a product is defective, in workmanship or materials and is removed and returned freight prepaid within one (1) year after the date of the initial system installation, Goldline will, at its option, either repair or replace the defective product and return it freight prepaid. The costs incurred in removal and/or reinstallation of the product are NOT covered under this warranty.

Accessory Products and Replacement parts—any pools, anywhere:

Goldline warrants any replacement parts or accessory products (any pool automation or chlorination product or part with a part number other than AQ-RITE-, AQ-TROL-, AQ-LOGIC-, AQL-P-, AQL-PS-, or AQL-CL-) to be free from defects in material or workmanship, under normal use and service for **one year** from date of the initial system installation, provided it is installed in accordance with the Goldline installation instructions and specifications provided with the product. If written proof of the date of the initial system installation is not provided to Goldline, the manufacturing datecode on the product or part will be the sole determinant of the date of the initial system installation.

If a product is defective, in workmanship or materials and is removed and returned freight prepaid within one (1) year after the date of the initial system installation, Goldline will, at its option, either repair or replace the defective product and return it freight prepaid. The costs incurred in removal and/or reinstallation of the product are NOT covered under this warranty.

Warranty exclusions:

1. Material supplied or workmanship performed by others in the process of installation
2. Damage resulting from improper installation including installation on pools larger than the product rating.
3. Problems resulting from failure to operate the products in accordance with recommended instructions contained in product's owners manual.
4. Problems resulting from failure to maintain pool water chemistry in accordance with recommended levels.
5. Problems resulting from tampering, accident, abuse, negligence, unauthorized repairs or alterations, fire, flood, lightning, freezing, external water, war, or acts of God.

THE EXPRESS LIMITED WARRANTY ABOVE CONSTITUTES THE ENTIRE WARRANTY OF GOLDLINE CONTROLS, INC. WITH RESPECT TO ITS POOLAUTOMATION AND CHLORINATION PRODUCTS AND IS IN LIEU OF ALL OTHER WARRANTIES, EXPRESSED OR IMPLIED, INCLUDING WARRANTIES OF MERCHANTABILITY OR FITNESS FOR A PARTICULAR PURPOSE. IN NO EVENT SHALL GOLDLINE CONTROLS, INC. BE RESPONSIBLE FOR ANY CONSEQUENTIAL, SPECIAL OR INCIDENTAL DAMAGES OF ANY NATURE WHATSOEVER.

NO WHOLESALE, AGENT, DEALER, CONTRACTOR, OR OTHER PERSON IS AUTHORIZED TO GIVE ANY WARRANTY ON BEHALF OF GOLDLINE CONTROLS, INC. THIS WARRANTY IS VOID IF THE PRODUCT HAS BEEN ALTERED IN ANY WAY AFTER LEAVING THE FACTORY.