

# Cristal-Flo™ II Filter Owner's Manual

**IMPORTANT SAFETY INSTRUCTIONS**  
*READ AND FOLLOW ALL INSTRUCTIONS*  
**SAVE THESE INSTRUCTIONS**

## Table of Contents

SECTION I.	How Your Filter Works .....	3
SECTION II.	Installation .....	4, 5
SECTION III.	Initial Start Up .....	5, 6
SECTION IV.	Cleaning Frequency .....	6
SECTION V.	Filter and Control Valve Functions .....	6
SECTION VI.	Filter Backwash Procedures.....	6, 7
SECTION VII.	Winterizing the Filter .....	7
SECTION VIII.	Troubleshooting .....	8
SECTION IX.	Technical Data .....	9, 10

### **WARNING**

Before installing this product, read and follow all warning notices and instructions accompanying this filter. Failure to follow safety warnings and instructions can result in severe injury, death, or property damage. Call (800) 831-7133 for additional free copies of these instructions.

### **Important Notice**



Attention Installer.

This manual contains important information about the installation, operation and safe use of this product. This information should be given to the owner/operator of this equipment.

**Pentair Water Pool and Spa, Inc**

1620 Hawkins Ave., Sanford, NC 27330 • (919) 774-4151  
10951 West Los Angeles Ave., Moorpark, CA 93021 • (805) 523-2400

 **Pentair**  
Pool Products®

**© 2009 Pentair Water Pool and Spa, Inc. All rights reserved.**

**This document is subject to change without notice**

1620 Hawkins Ave., Sanford, NC 27330 • (919) 566-8000  
10951 West Los Angeles Ave., Moorpark, CA 93021 • (805) 553-5000

Pentair Water Pool and Spa® is a registered trademark of Pentair Water Pool and Spa, Inc, and/or its affiliated companies in the United States and/or other countries. Unless noted, names and brands of others that may be used in this document are not used to indicate an affiliation or endorsement between the proprietors of these names and brands and Pentair Water Pool and Spa, Inc. Those names and brands may be the trademarks or registered trademarks of those parties and others.

## Section I. How Your Filter Works.

Your high rate sand filter is designed to produce clear, sparkling water and operate for years with a minimum of maintenance when installed, operated and maintained in accordance with these instructions.

Your filter uses special filter sand to remove dirt particles from the water. Dirt is collected in the filter by the sand bed as water flows through the filter. Water enters the filter through the valve on top of the filter and is distributed evenly downward across the sand bed. The dirt is removed by the sand and the clean water flows through the piping (laterals) at the bottom of the filter, up through the standpipe, back to the valve on top of the filter, where the clean water is returned to the pool through the piping or hoses.

### WARNING

This filter operates under high pressure. When any part of the circulating system (e.g., clamp, pump, filter, valves, etc.) is serviced, air can enter the system and become pressurized. Pressurized air can cause the lid or control valve to blow off which can result in severe injury, death, or property damage. To avoid this potential hazard, follow these instructions.

1. Before repositioning valves and before beginning the assembly, disassembly, or adjustment of the clamp or any other service of the circulating system: (a) Turn the pump off and shut off any automatic controls to ensure the system is not inadvertently started during the servicing; (b) Open manual air relief valve; (c) Wait until all pressure is relieved, pressure gauge must read zero (0).
2. Whenever installing the filter clamp, follow the **filter lid and clamp installation instructions** exactly.
3. Once service on the circulating system is complete, follow **system restart instructions** exactly.
4. Maintain circulation system properly. Replace worn or damaged parts immediately (e.g., clamp, pressure gauge, relief valve, o-rings, etc.).
5. Be sure that the filter is properly mounted and positioned according to instructions provided.

After a period of time, dirt will accumulate in the filter causing a resistance to the flow of water through the filter. This resistance results in a diminished flow of water and a rise in the pressure of the filter. Eventually the filter sand will have removed so much dirt and the filter pressure risen to such a point that it will be necessary to clean (backwash) your filter.

By setting the valve on top of the filter to the backwash position, the flow of water is automatically reversed through the filter so that the flow of water is directed to the bottom of the filter, up through the sand bed flushing, the dirt and debris out through the waste line. Once the backwash procedure is complete, the valve is manually returned to its filter position to resume normal filtration.

The filter's function is to remove suspended matter from the water. It does not sanitize the water. For sparkling clear water the water must be sanitized as well as balanced. Pool chemistry is a specialized area, and you should consult your local pool service specialist for specific details. In general, proper pool sanitation requires a free chlorine level of 1 to 2 PPM and a PH range of 7.2 to 7.6.

### WARNING

Failure to operate your filter system or inadequate filtration can cause poor water clarity obstructing visibility in your pool. Poor water clarity may obscure objects in the water which while swimming and diving could cause severe personal injury or death. Never swim in a pool with poor water clarity.

Your filtration system should be designed to meet your local health codes. As a minimum, you must be sure that your system will turnover the total volume of water in your pool at least twice in a twenty-four hour period.

### WARNING

Failure to operate your filter system or inadequate filtration can cause poor water clarity obstructing visibility in your pool and can allow diving into or on top of obscured objects, which can cause serious personal injury or drowning.

## Section II. Installation.

1. Read and understand all instructions before attempting to install, operate or maintain your pump and filter system. Due to the different models some instructions may not apply to your specific system or certain instructions may be duplicated in other component manuals.
2. Provide space and lighting for routine maintenance access. Locate the system close to the pool.

Do not mount electrical controls over the filter. One needs to be able to stand clear of the filter when starting the pump.

3. Remove all individual components from carton and inspect for any visible damage. If carton or parts are damaged contact seller or freight company.

### WARNING

Blockage of suction fittings can cause severe or fatal injury due to drowning. Small children using pool/spa equipment must always have close adult supervision. To reduce the risk of injury, do not permit children to use this product unless they are closely supervised at all times.

4. At this point you need to move the filter into its final position. The system must be placed on level solid earth. The filter filled with sand and water can weigh several hundred pounds.
5. Be certain to install the precise amount of filter sand listed on your filter nameplate. You must use only No. 20 standard silica sand having a uniformity coefficient of 1.75 or less. No. 20 silica sand has a particle size of .018-.022 inches (.45 to .55 mm). Before pouring the sand into the filter, look inside and check the lower underdrain for broken or loose laterals (or fingers), which may have been accidentally damaged by rough handling during shipment. Replace any broken parts if necessary.

6. Install the sand guide in the top of the filter and fill the tank about half full with water. Pour the sand into the top of the filter at a slow rate so that the weight of the sand does not damage the laterals. After filling to the proper level, remove and discard the sand guide. Wash away all sand around the opening at the top of the tank.
7. Be sure top of filter is free of any sand or debris and valve o-ring is in place on valve body. Install valve so that the port locations are in the desired final position. **Valve ports are labeled with the location of where they should be connected i.e. pump port must go to pump discharge, waste port must go to the waste line and return port must go to the pool return.**
8. Insure that the valve is firmly pushed into the top of the tank and that the flange of the tank and the flange of the valve are contacting each other. See Diagram D.

DIAGRAM D

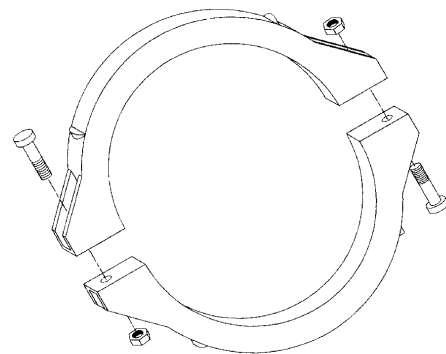
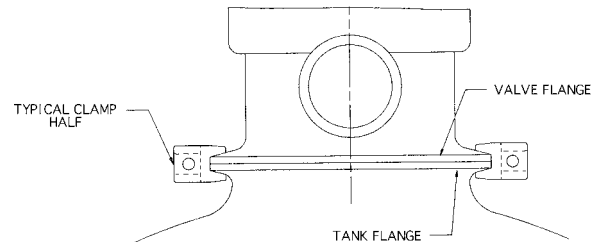

9. The plastic clamp can now be installed. Place the clamp half over the valve flange and the tank flange as shown in diagram D. Insert the clamp screws and nuts into the clamp making sure that the nuts are located in the special hexagonal retainer slots on the clamps.

10. Tighten clamp screws firmly and visually check the valve tank and clamp assembly to insure that the joint is correctly assembled.

**⚠ WARNING**

Improper tank valve assembly could cause the valve to blow off and cause severe injury and/or property damage.

11. The filter unit has a maximum operating pressure listed on the filter name plate. **DO NOT OPERATE this unit above the maximum operating pressure of the valve or the filter.** Never connect the filter and valve unit to a pump which can generate a pressure that exceeds the operating pressure of the filter or valve.
12. Use sealant on all tapered male connections of pipe and fittings. Use only sealant compounds suited for plastic pipe. Support pipe to prevent strains on filter, pump or valve. **DO NOT USE PETROLEUM BASED PRODUCTS. NOTICE: All valve Internal threads are tapered except the air bleeder connection. Do not over tighten tapered thread connections.**
13. Install pressure gauge in 1/4" NPT port directly across from the pump port of the valve.
14. Never store pool chemicals within 10 feet of your pool filter, pump or valve. Pool chemicals should always be stored in a cool, dry, well ventilated area.

**⚠ WARNING**

Chemical fumes and/or spills can cause severe corrosive attack to the filter and pump structural components. Structurally weakened components can cause filter, pump or valve attachments to blow off and could cause severe bodily injury or property damage.

**⚠ WARNING**

The system's centrifugal pump operates with electrical voltage, and can generate both vacuum and pressure in the water system. When properly wired and plumbed, this pump will operate in a safe manner.

**⚠ WARNING**

Hazardous voltage - can cause severe or fatal injury. Always install a suitable GFCI at the power source of this unit as an added safety precaution. Article 680-31 of the NEC requires that a GFCI be used if this pump is used with storable pools.

15. Avoid over tightening the pipe threads when connecting fittings to the pump or valve. Proper procedure is to apply a pipe sealant to the thread and then install hand tight plus 1 turn. **DO NOT OVER TIGHTEN.**

**Section III. Initial Start Up.**

1. Be sure the correct amount of Silica filter sand is in the tank and that all connections have been made and are secure.
2. Check that the backwash is open so that water is free to flow from the pool and out the backwash line. Set the control valve to Backwash position.

**⚠ WARNING**



This filter operates under pressure. With the valve clamped properly and operated without air in the system, this filter will operate in a safe manner. Air entering the filter and the valve not clamped correctly can cause the valve to be blown off, which could cause severe personal injury and/or property damage.

**⚠ CAUTION**

Always turn pump off before changing valve positions. Changing valve positions while the pump is running can damage the control valve, which may cause personal injury or property damage.

3. **Stand clear of the filter.** Prime and start pump according to the pump instructions allowing the filter tank to fill with water. Once the water flow is steady out of the waste line, run the pump for at least two minutes. This initial backwashing of the filter is recommended to remove any impurities of fine sand particles in the Silica sand media.

4. Turn the pump off and set valve to rinse position. Ensure that all pool suction and return lines are open so that the water is free to flow from the pool to waste. **Stand clear of filter** and start the pump.

5. Run the pump for at least two minutes.

6. Turn the pump off and set valve to filter position. Ensure that all pool suction and return lines are open so that water is free to flow from and to the pool. Stand clear of filter and start the pump.

7. Your filter has now started its filtering cycle. You should check that water is returning to the pool and take note of the operating pressure. My original starting pressure is \_\_\_\_\_ PSI with the filter clean.

**⚠ CAUTION**

To prevent damage to the pump and filter and for proper operation of the system, clean pump strainer and skimmer baskets regularly.

8. Check the system for water leaks. If a leak is found, shut pump off before correcting the leak.

9. As the filter removes dirt and impurities from the pool water, the accumulation will cause the filter pressure to rise and flow to diminish. When the pressure gauge reading is 10 PSI higher than the clean filter reading noted above, it is time to backwash the filter.

**Section IV. Cleaning Frequency.**

1. Cleaning frequency will vary from pool to pool and with other factors such as weather condition, heavy rains, dust, pollen, bather load, and water chemistry. Check the pressure gauge reading on a regular basis and when the pressure gauge reading increases 10 PSI over the initial clean filter reading, it is time to backwash your filter.

2. It is important NOT to backwash the filter solely on a timed basis such as every two days. It is also important to note that backwashing too frequently actually causes poor filtration.

**Section V. Filter and Control Valve Functions.**

**FILTER -** From pump, through valve, downward through filter sand bed, up through center pipe to valve return port, and back to the pool for normal filter action and vacuuming pool through filter.

**BACKWASH -** From pump, through valve down through center pipe, up through filter sand to valve, and out waste port. This position is used for cleaning filter by reversing flow.

**RINSE -** From pump through valve downward through filter sand, up through center pipe to valve and out waste port. This position is used for start up cleaning and resettling filter bed after backwashing.

**WASTE -** From pump, through valve (bypasses filter) and goes to waste port. This position is for vacuuming directly to waste, lowering pool level, or draining pool.

**CLOSED -** NO FLOW IN THIS POSITION – DO NOT USE THIS SETTING WITH PUMP OPERATING.

**RECIRCULATE -** From pump, through valve, bypasses filter and goes to return port and back to pool. This position is for circulating water without going through filter.

**WINTERIZING -** Valve position for a winterized filter, see page 10.

**Section VI. Filter Backwash Procedures.**

**⚠ WARNING**

Failure to operate your filter system or inadequate filtration can cause poor water clarity obstructing visibility in your pool. Poor water clarity may obscure objects in the water which while swimming and diving could cause severe personal injury or death. Never swim in a pool with poor water clarity.

1. Turn off pump.

2. Ensure that suction and backwash lines are open so that water is free to come from the pool and flow out the backwash line. Set the control valve to backwash position.

3. **Stand clear of the filter** and start pump.

4. Backwash filter for approximately 3-5 minutes or until backwash water is clean.
5. Turn off pump. Set control valve back to rinse position.
6. **Stand clear of the filter** and start pump.
7. Rinse filter for approximately 3-5 minutes.
8. Turn off pump. Set control valve back to filter position.
9. **Stand clear of the filter** and start pump.
10. The filter has now started its filtering cycle. Check that water is returning to the pool and take note of the filter pressure.
11. The filter pressure in step 10 above should not exceed the pressure originally observed on the filter when it was initially started. If after backwashing the pressure is 4-6 PSI above the start condition, it may be necessary to change the sand in the filter.

## Section VII. Winterizing the Filter.

1. In areas that have freezing winter temperatures, the pool equipment must be winterized to protect it from damage.
2. Backwash the filter. Shut off the pump and set the control valve to the winterize position.
3. Remove the drain port cap at the bottom of the filter.

---

### IMPORTANT NOTE

Remove drain port cap only for draining water from filter. Removing the entire fitting will allow sand to drain also. *The filter will drain slowly. Leave the drain port cap off and store it during the time the system is shut down.*

---

 <b>CAUTION</b>
--

<p>The control valve should be left in the winterize position during the shutdown season so that the rubber seal of the valve diverter has no pressure on it. Failure to do so can damage the valve diverter seal which can cause property damage from leaking water.</p>
---

4. Drain all appropriate system piping.
5. It is recommended that the pump and filter be covered with a tarpaulin or plastic sheet to inhibit deterioration from the weather. **DO NOT** wrap pump motor with plastic.

## Section VIII. Troubleshooting.

Problem	Cause	Remedy
Pool water not sufficiently clean.	<ol style="list-style-type: none"> <li>1. Pool chemistry not adequate to inhibit algae growth.</li> <li>2. Too frequent a backwash cycle</li> <li>3. Improper amount or wrong sand size.</li> <li>4. Inadequate turnover rate.</li> </ol>	<p>Maintain pool chemistry or consult pool service technician.</p> <p>Allow pressure to build to 10 PSI above clean filter condition before backwashing.</p> <p>Check sand bed depth and sand size or consult pool service technician.</p> <p>Run system for longer time or consult dealer or pool service technician.</p>
Higher filter pressure.	<ol style="list-style-type: none"> <li>1. Insufficient backwashing.</li> <li>2. Sand bed plugged with mineral deposits.</li> <li>3. Partially closed valve or restriction.</li> </ol>	<p>Backwash until effluent runs clear.</p> <p>Chemically clean filter.</p> <p>Open valve or remove obstruction in return line.</p>
Short filter cycles.	<ol style="list-style-type: none"> <li>1. Improper backwashing.</li> <li>2. Pool chemistry not adequate to inhibit algae growth.</li> <li>3. Plugged sand bed.</li> <li>4. Flow rate too high.</li> </ol>	<p>Backwash until effluent runs clear.</p> <p>Maintain pool chemistry or consult pool service technician.</p> <p>Manually remove top 1" surface of sand bed and chemically clean as required.</p> <p>Restrict flow to capacity of filter.</p>
Return flow to pool diminished, low filter pressure.	<ol style="list-style-type: none"> <li>1. Obstruction in the pump hair and lint pot.</li> <li>2. Obstruction in pump.</li> <li>3. Obstruction in suction line to pump.</li> </ol>	<p>Clean basket in strainer.</p> <p>Disassemble and clean pump.</p> <p>Clean skimmer basket. Remove obstruction in lines. Open valves in suction line.</p>
Sand returning to pool.	<ol style="list-style-type: none"> <li>1. Broken underdrain lateral.</li> <li>2. Backwash rate too high.</li> </ol>	<p>Replace broken or damaged laterals.</p> <p>Reduce backwash flow rate.</p>



## Section IX. Technical Data

### Replacement Parts List - 6 Way Valve

Item	Part No.	Description	Qty.
1	27-2520	Handle	1
2	27-2505	Washer-Plastic	2
3	27-2405	Screw-Handle	1
4	27-2527	Valve Top - Black	1
5	27-2511	O-Ring-Diverter Shaft	1
6	35-4053	O-Ring	1
7	27-2535	Spring - 100 Lb. - 1 3/8 O.D. SS	1
8	27-2512	Diverter W/Gasket	1
9	35-4541	Screw #10-24 Hex Pan HD	6
10	27-2555	Washer 9/16 SS	6
11	27-2554	Nut - #10-24 Serrated Flange SS	6
12	27-2530	Valve Body W/Differ - Clamp Style	1
13	27-3512	Air Bleeder W/O-Ring	1
14	27-2541	O-Ring - 3/16" x 4 5/8" I.D.	1
15	15-2165	Clamp Assembly (See Note 2)	1
16	19-0059	Pressure Gauge	1

**NOTE:**

1. Valve Top Assembly P/N 27-2531 consists of items 1 thru 8 and valve instructions 27-2517.

2. Clamp halves, nuts and bolts sold only in Assembly 15-2165.

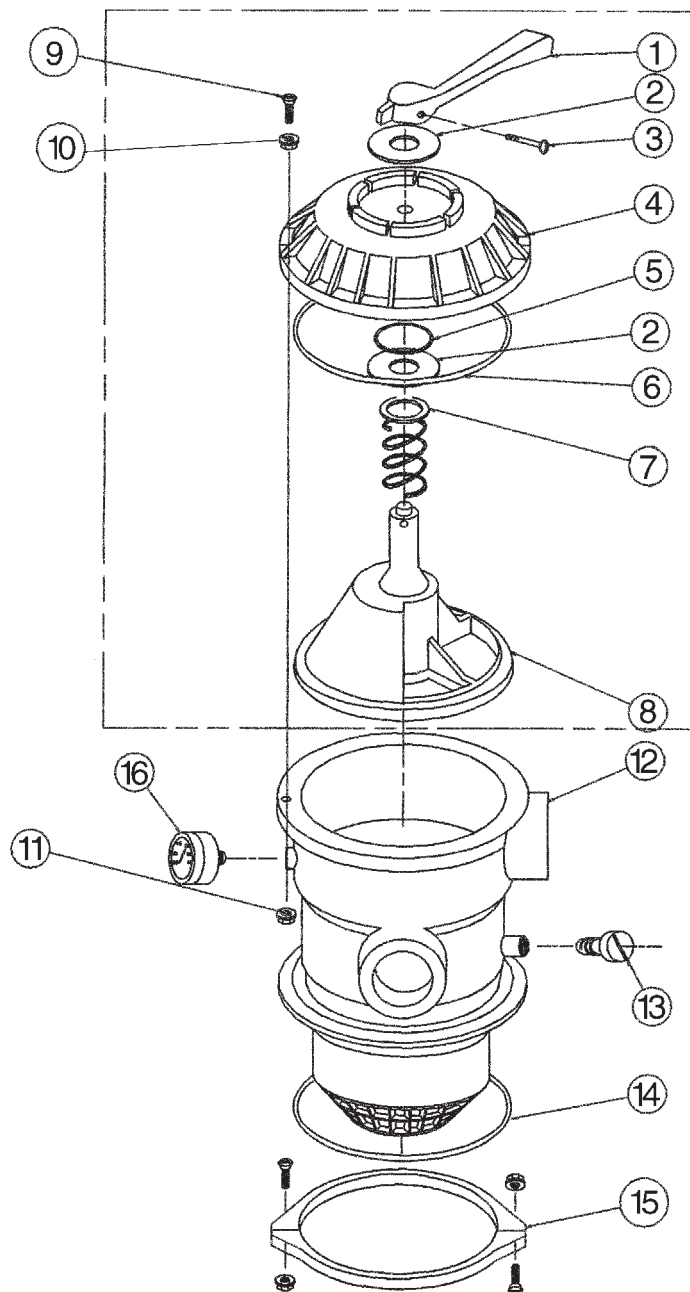

Section IX. Technical Data

Replacement Parts List – Sand Filter

Cristal-Flo II Filter Replacement Parts

Item	Part Number	Description	Quantity
1	262506	Valve, 1-1/2 Inch, 6-Way	1
2	272541	O-Ring Valve Body	1
3	152165	Clamp Assembly	1
4	152229	Piping Assembly – 16” Tank	1
4	152228	Piping Assembly – 19” Tank	1
4	152227	Piping Assembly – 22” Tank	1
4	152000	Piping Assembly – 24” Tank	1
4	152226	Piping Assembly – 26” Tank	1
5	150084	Lateral – 16” & 19” Tanks	6
5	150085	Lateral – 22”, 24”, & 26” Tanks	6
6	145364	Assembled Tank w/Drain – 16” Tank	1
6	145365	Assembled Tank w/Drain – 19” Tank	1
6	145366	Assembled Tank w/Drain – 22” Tank	1
6	145369	Assembled Tank w/Drain – 24” Tank	1
6	145370	Assembled Tank w/Drain – 26” Tank	1
7	154711	Sand Drain	1
8	154715	Gasket (Sand Drain)	1
9	154712	Drain Cap	1
10	154926	Foot, 16” Tank	1
10	154520	Foot, 19”, 22”, 24”, & 26” Tanks	1
11	190059	Pressure Gauge	1
12	155051	Sand Guide	1

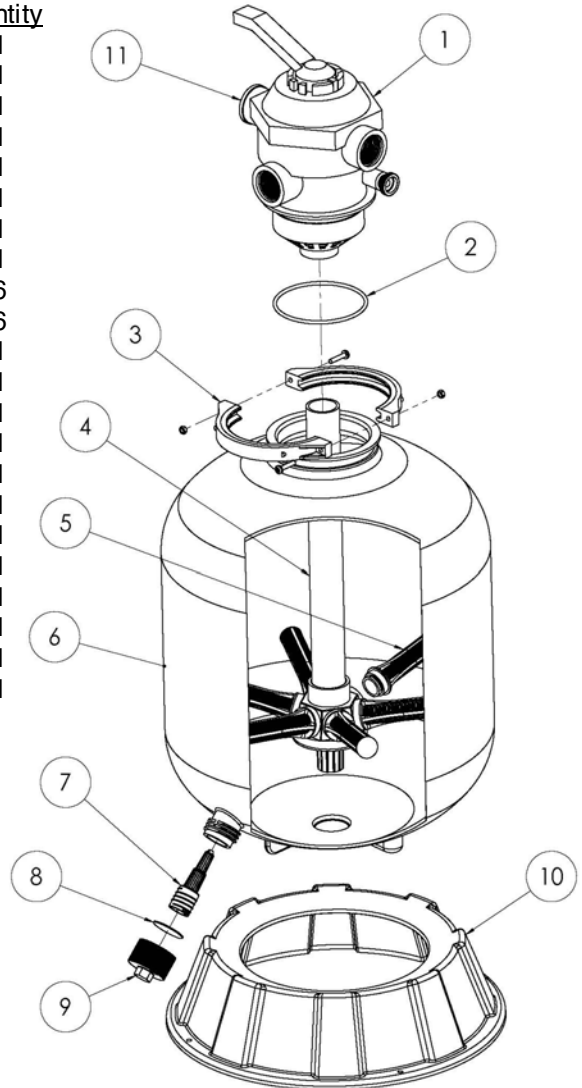

Available Replacement Hose Kits\*

- 155151 Kit, Flex Hose, 6ft
- 155005 Kit, Flex Hose, 12ft

\* Replacement Hose Kits include two (2) hoses, four (4) hose adaptors, and four (4) hose clamps

Tank Diameter	Filter Area Sq. Ft.	Lbs. of Sand Required	Max. Working Pressure	Vrtl Clearance Required	Design Flow Rate GPM	Max Water Temp.
16"	1.19	100	30	45	35	95 F
19"	1.92	150	35	49	40	95 F
22"	2.64	250	40	55	60	95 F
24"	3.15	300	50	58	70	95 F
26"	3.69	350	50	60	75	95 F



**SAVE THESE INSTRUCTIONS**