

OWNER'S MANUAL

 **Polaris Watermatic**

---

C660 ORP/pH Controller, 120V

 **Polaris**

# IMPORTANT SAFETY INFORMATION

When installing and using this electrical equipment, basic safety precautions should always be followed, including the following:

## **READ AND FOLLOW ALL INSTALLATION INSTRUCTIONS.**

Installation of this equipment should be performed by a licensed electrician and conform to all National Electric Code (NEC), state and local codes. Installations in Canada must comply to CEC requirements.

### **WARNING: To reduce the risk of electrical shock:**

- Turn off or disconnect the power source before installing, opening the door, or adjusting the internal workings of the controller.
- Install all electrical equipment at least 10 feet (3 m) from inside wall of pool or spa.
- Connect this device only to a grounding-type receptacle protected by a ground-fault circuit interrupter (GFCI).
- Do not use an extension cord, connect the controller directly into the outlet. Do not bury the cord..

**WARNING:** To reduce risk of injury, do not permit children to use this product unless they are closely supervised at all times.

For proper operation, it is imperative that the system has proper flow past the sensors when the pool filtration system is running.

When automating a body of water, size the feeders so desired levels can be attained in short operating cycles. If feeders are unable to keep up with demand within a short time frame, automation becomes ineffective.

Always test and adjust sanitizer and pH to acceptable levels before activating a new system. Automated chemical controllers are designed to maintain water chemistry, not balance the pool.

## **SAVE THESE INSTRUCTIONS.**

# Table of Contents

Introduction	2
Specifications	3
Components	3
Features	4
Flow Cell Assembly	4
PPM Readout	4
Timed Feed Delay	4
Controller Panel Features	5
Controller Function Overview	6
Default Settings	6
Selector Knob Settings	6
Dip Switches	8
Installation	10
Feeding Systems	12
Site Assessment and Controller Installation	12
Flow Cell Assembly	12
Sensors	16
Flow Switch	16
Dip Switches	16
System Start-Up	17
pH Level Settings	18
Sanitizer Settings	19
Operation and Maintenance	20
Out-of-range Alert	20
Cleaning the Sensor Tips	20
Checking the ORP Sensor	21
Checking the pH Sensor	21
Winterizing	22
Troubleshooting	23
Guidelines for Using ORP for Water Maintenance	24
Warranty	26
Appendix	28

# Introduction

The Polaris Watermatic® C660 ORP/pH Controller automatically monitors and maintains both the sanitizer level and pH balance in swimming pools, spas, or any circulating water system that requires water chemistry management. Easy to install and simple to operate, the C660 can be used with liquid feed pumps, granular feeders, tablet erosion feeders, and ozone generators. **It is not warranted or recommended for use with chlorine gas systems.**

During the filtration cycle of the pool or spa, the C660 constantly measures the sanitizer or ORP (Oxidation-Reduction-Potential) level and pH balance of the water. Measurements are displayed on the controller's ORP and pH digital readouts. If the ORP or pH falls below a pre-determined set point, the controller activates the chemical feeder until the preset point is reached. Built-in safety features prevent the feeders from activating if the sanitizer or pH balance is outside of the controller's range.

The C660 has two standard power receptacles for the ORP and pH feeder hookups.

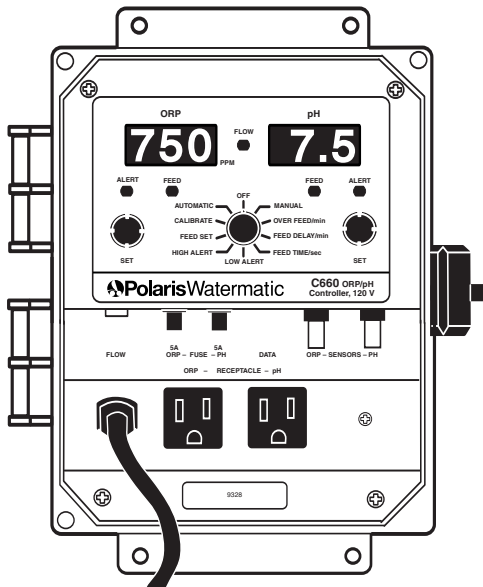

# Specifications

<b>pH Control Range:</b>	7.0 to 8.0
<b>ORP Control Range:</b>	400 mV to 900 mV
<b>Input Power:</b>	120 VAC 60 Hz, 3-wire grounded power cord. GFCI source required
<b>Controller Power:</b>	Less than .5 amp internally fused
<b>Output Power:</b>	120 VAC 60 Hz, 5 amp fused, two 3-wire grounded power receptacles
<b>Display:</b>	Digital readouts
<b>Operating Temperature:</b>	40 - 120° F
<b>Sensors:</b>	pH: glass combination with 10' cable ORP: platinum combination with 10' cable

## Selectable features:

- Desired ORP/pH settings
- Manual operation
- pH and PPM calibration
- ORP and pH timed or continuous feed
- Adjustable alerts on ORP and pH
- Maximum feed time option
- Safety interlock between pH and ORP
- Front face lockouts
- Acid/Base feed

## Components

The C660 ORP/pH controller box contains:

- ORP/pH Controller
- Flow Assembly with Flow Switch
- ORP Sensor
- pH Sensor

# Features

## Flow Cell Assembly

The flow cell assembly houses the sensors and provides a sample port for manual testing. It also contains an integrated flow switch/flow indicator that prevents the feeder(s) from feeding if there is insufficient flow.

The flow switch requires at least 0.3 GPM to work properly. When the flow exceeds the minimum flow rate, the black piston in the switch chamber moves to the top, closes the switch and sends a signal to the controller to allow its operation. When using peristaltic pumps, the flow switch eliminates the pumping of chemicals while the filter system is off.

## PPM Readout

The controller is factory set with no ppm (parts per million) readout. If OFF is not displayed in the digital window, turn the ORP Set Knob until OFF appears in the window.

## Timed Feed and Delay Cycles

For most controller applications, the Continuous Feed mode is appropriate. However, if you are using the controller in one of the following situations, you will need to change the feed settings to allow for a timed-feed cycle followed by a delay cycle.

- With a Watermatic G1000 or G7500 feeder.
- With a peristaltic pump feeding the sanitizer or pH, and you are experiencing overfeeding.
- With an erosion feeder in a spa or small body of water, and you are experiencing spiking.
- In an application where the ORP sensor is installed downstream of the introduction of the sanitizer (the pH sensor should always be located upstream from the introduction of the pH balance).

In a timed feed and delay cycle, the feeder dispenses a dose of sanitizer or pH, and is then unable to dispense again for a set period of time. The delay allows the chemical to be circulated through the pool and filtration system.

Refer to the Appendix for more information.

# Controller Panel Features

#	DESCRIPTION	FUNCTION
1	ORP Digital Display	Indicates sanitizer level
2	Selector Knob	Selects controller mode
3	ORP Alert Light	Indicates the ORP level is out of range
4	ORP Feed Light	ORP sanitizer feeder is activated (or in delay)
5	ORP Set Knob	Sets the desired sanitizer mode
6	Flow Switch Connection	Connects flow switch to controller
7	Fuses	Continuous feed = 5 amp, Timed feed/delay = 1.5 slow-blo
8	Power Cord	3-wire grounded power cord with plug
9	Flow Light	Indicates sufficient flow/pressure to operate the controller
10	pH Digital Display	Indicated pH level
11	pH Alert Light	Indicates that pH is out of range
12	pH Feed Light	Indicates the pH feeder is activated (or in delay)
13	pH Set Knob	Sets the desired pH level of the water
14	ORP and pH Sensor Connectors	BNC jacks
15	Data port	Optional accessory connection
16	5 amp ORP/pH Outlets	3-wire grounded power receptacles

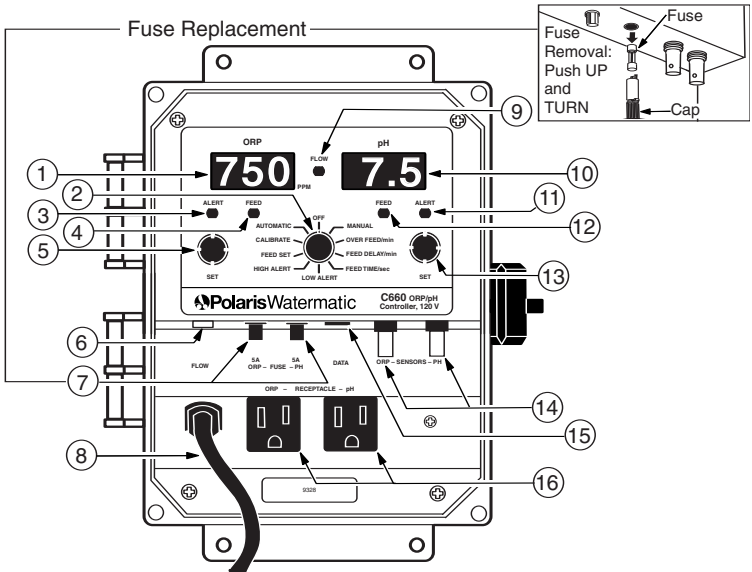

# Controller Function Overview

## Default Settings

At startup, the controller settings will default to the settings noted below. After the initial start-up, the controller will retain the last setting chosen by the user.

	<u>ORP</u>	<u>pH</u>
Feed Set	650	7.5
High Alert	900	8.0
Low Alert	100	7.0
Feed Time	4.8	0.6
Feed Delay	10	5
Overfeed	OFF	OFF

## Selector Knob Settings

The selector knob located on the face of the unit allows users to easily choose certain adjustable operational features.

- The **OFF** setting turns off the control feature without turning off the power to the board.
- The **AUTOMATIC** setting is the normal operation mode. It and displays the current status of the ORP and pH levels, as well as PPM if activated.
- The **CALIBRATION** setting enables use of the pH Set Knob which allows the digital pH reading to be set to a test kit or a known buffer. The pH sensor should be recalibrated every four to eight weeks.

When calibrating to a test kit, always take the water sample from the sample port at the bottom of the flow cell.

- The **FEED SET** setting allows the operator to set the ORP and pH settings to a desired level by using the appropriate Set Knob. The feed set range is:  
ORP: 400 to 900  
pH: 7.0 to 8.0



- The **HIGH ALERT** setting allows the operator to set the ORP and pH levels to the highest possible level without sounding an alarm.

ORP: 650 to 900

pH: 7.5 to 8.4

The high alerts can also be turned off.

- The **LOW ALERT** setting allows the operator to set the ORP and pH levels to the lowest possible level without sounding an alarm.

ORP: 100 to 640

pH: 6.8 to 7.4

The low alerts can also be turned off.

**Note:** The reading must be above or below the alert level for ten minutes before the controller initiates the alarm and shuts down the respective side of the controller. The system must be brought into range for one minute for the controller to restart.

- The feed time feature allows the operator to set the feeder's operational duration for specific applications. See Appendix for more information. It adjusts the system from the continuous feed mode to a timed-feed cycle that must then be followed by a delay cycle.

The **FEED TIME** setting adjusts the feed time from continuous (CONT) to .6, 1.2, 1.8, 2.4, 3.0, 4.8, 6.0, 7.2, 8.4, 10, 15, 20, 30, 60, 120, 180, 240, 300, 600 or 900 seconds for the ORP and pH levels.

- The feed delay feature is a preset interval between possible feed times that must be used with the feed time feature.

The **FEED DELAY** setting adjusts the delay time from 1 to 99 minutes. It is only active when the FEED TIME setting is used. When continuous feed is selected, the feed delay will be off.

- The **OVERFEED** setting is a safety feature that allows the operator to set a maximum allowable feed time for the sanitizer or pH under normal conditions. It can be set from 0 to 99 minutes on either ORP or pH, but is only operable when feed time is in continuous mode.

When the maximum feed time is reached, the system shuts down and moves into Service Mode (the display flashes). To reset, remedy the malfunction and turn the controller off, then on.

10. The **MANUAL** setting allows the operator to manually control the feeders. In this mode, when a set knob is turned, the feeder will progress through one feed cycle. If the continuous mode is selected, a slight turn of the desired set knob will start the respective feeder for 30 seconds. To stop the feeder prior to the 30 second feed time, the selector knob can be turned to the OFF position.

The setting cannot be used while the feed light is on as the feeders are already feeding.

## DIP Switches

The controller has six dip switches located on the back of the module. The dip switches control:

- Interlocking ORP and pH
- Acid/Base
- Lockout features
- Reset/test features

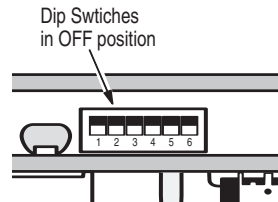

All dip switches are shipped preset to the OFF position.

### Dip Switch #1

The controller is preset at the factory to allow the ORP to feed regardless of the pH level.

**Activating this switch will** override this feature and **allow the feeding of the sanitizer, only if the pH reading is within the controller range** (above or below the pH limits set by the operator). Since the ORP reading is dependent on the pH (i.e. as the pH rises, the ORP lowers), this setting avoids oversanitizing as a result of a high pH level. If the pH is out of range, the sanitizer will not feed but the pH alert light will illuminate.

## Dip Switch #2

The controller is preset at the factory to allow simultaneous feeding of pH and ORP.

**When turned ON, this switch will not allow ORP and pH to feed at the same time.** In some installations, the sanitizer and the pH are introduced into the filtration system in close proximity to each other. Simultaneous feeding of acid for pH control and liquid chlorine to sanitize can cause chlorine gas bubbles in the return lines. This option prevents the sanitizer from feeding until the pH feed cycle is complete. If the system happens to run out of acid to feed, the pH feeder will continue to run and the sanitizer feeder will not be activated.

## Dip Switch #3

The controller is preset at the factory to feed acid. When feeding base, turn ON switch #3.

**OFF = Acid Feed**

**ON = Base Feed**

## Dip Switch #4

This feature allows the user to set the operating parameters on the front of the board, and **lock in the settings**. With this switch enabled, CALIBRATE, AUTOMATIC and OFF are the only functioning settings. To reset the operating parameters, turn this dip switch to OFF.

## Dip Switch #5 and #6

These **test and reset switches** must remain OFF at all times.

# Installation

## Feeding Systems

Install the feed system as shown. If your model differs from these systems, refer to the installation manual provided with it for the appropriate installation methods.

### Liquid Feeder

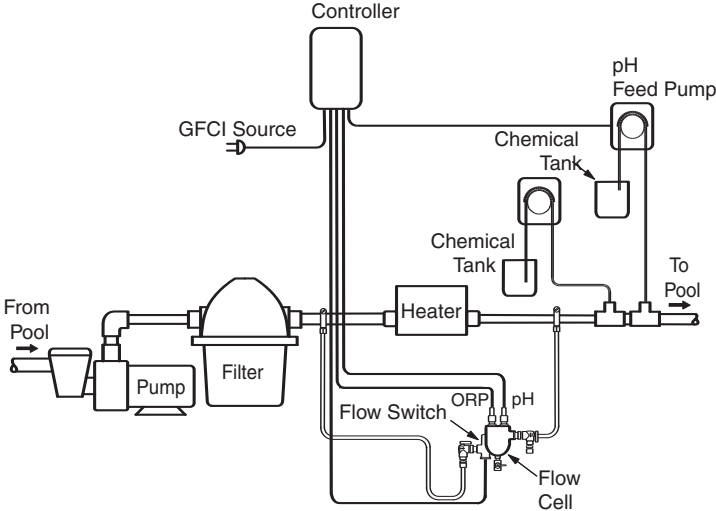

**Erosion Feeder**

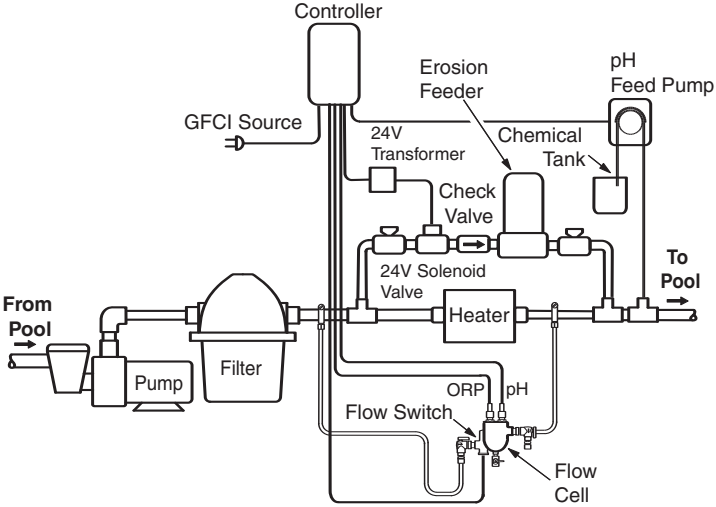

Granular feeders should not be used below water level.

**Granular Feeder**

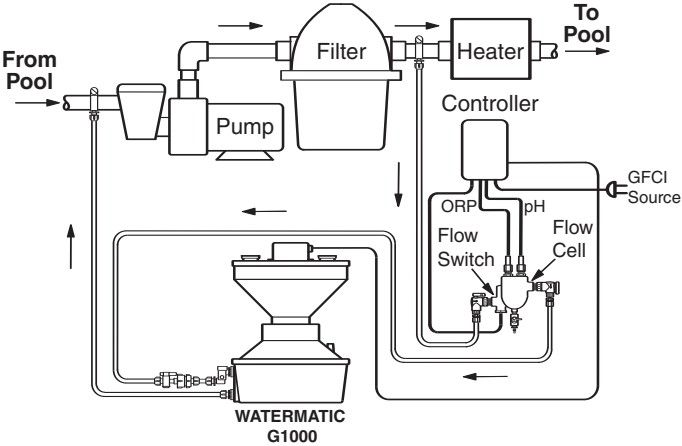

## Site Assessment and Controller Installation

Before installing the controller, it is important to do a site assessment to consider where and how you will mount the unit. The controller should be mounted on a wall or other surface within eight feet of the feeder, at least ten feet away from the edge of the water, in close proximity to the time clock, and within six feet of the GFCI power source.

Once the best site selected, obtain all necessary mounting screws or anchors (no mounting screws are provided with the controller). Securely mount the controller on the wall or panel.

## Flow Cell Assembly

Locate the flow cell within eight feet of the controller, mounted on a vertical surface.

It is imperative that there is proper flow past the sensors when the pool filtration system is running. The flow cell must be plumbed so the pressure difference between the inlet (flow switch side) and the outlet is sufficient to ensure flow through the cell. If the 3/8" tubing provided is being used, a minimum pressure differential of 3 PSI and 0.3 GPM is required to activate the flow switch. It is also desirable to have filtered water pass over the sensors to minimize cleaning and maintenance.

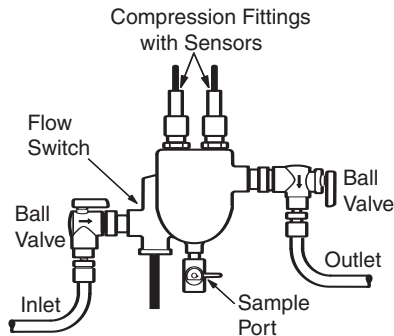

There are three suggested methods to install the flow cell.

1. Plumb the inlet to the flow cell after the filter and the outlet of the flow cell after the heater using the saddle clamps provided. Fittings for 1/4" NPT taps are also included.

### Pressure Differential Installation

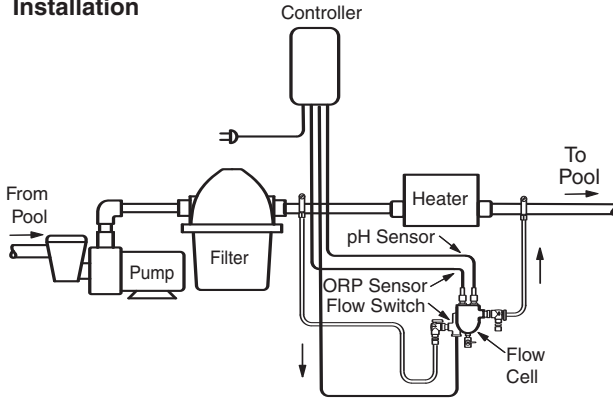

2. Plumb from after the filter to before the pump. This ensures excellent flow but the flow must be adjusted so the sensors are not subjected to a suction environment. Open the sample port (see Flow Cell Assembly drawing) to verify that water is flowing freely from it.

### Pressure/Suction Method

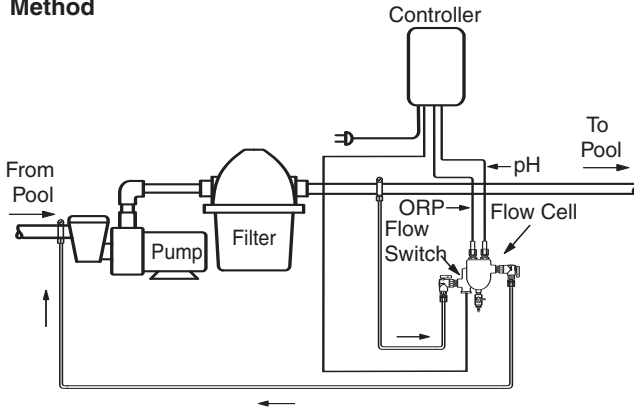

- Plumb from before the filter to after the heater, using an inline filter to minimize the possibility of debris coming into contact with the sensors.

**Pressure Differential  
Alternative Installation**

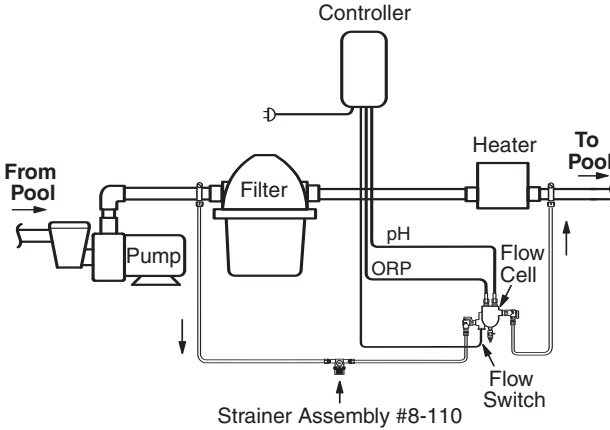

**G7500 Granular Feeder Installation**

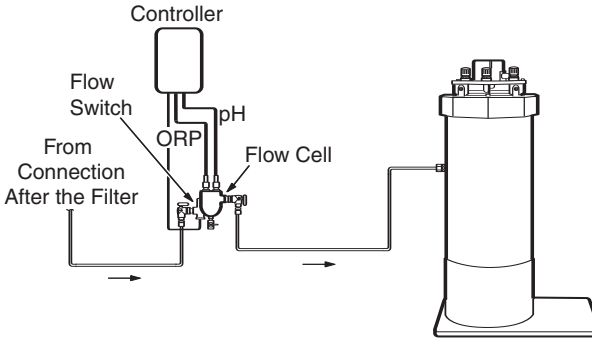

Be aware that solar systems and other factors can alter pressure differentials in a system, adversely impacting flow through the flow cell.



The flow cell comes fully assembled. It is setup to use the 3/8" tubing provided; however, other sized tubing or 1/2" hard plumbing can be used. To use an alternative tubing, remove the 90° on/off valves and plumb according to the application.

1. **If using a saddle clamp**, drill a 7/16" hole in the pipe on the pressure side of the pump. Insert the 1/8" Jaco fitting (#2) through the clamp (#3) and place the nylon jam nut (#4) onto the Jaco fitting. Slide the pipe seal washer (#5) onto the end of the Jaco fitting. Insert the completed assembly into the hole in the pipe and tighten the clamp. Test for leaks.

If the pipe is larger than 2" in diameter, two clamps joined together will be required per each hole.

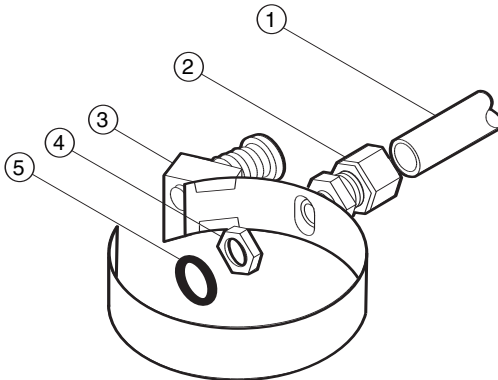

**If using a pipe tap**, drill a 7/16" hole and tap a 1/4" NPT hole. Apply RTV silicone, teflon stick or teflon paste to the threads on the Jaco fitting and screw securely into the pipe. Test for leaks.

2. Cut the tubing (#1) to the appropriate length. Slightly loosen the Jaco fitting in the pipe and insert the tubing into it. Take the free end of the tubing and insert it into the Jaco fitting on the flow switch side of the flow cell.
3. Complete these steps for the return side of the flow cell using the appropriate remaining parts. Take the free end of the tubing and insert it into the Jaco fitting on the outlet side of the flow cell.

## Sensors

Carefully unpack the ORP and pH sensors, and the o-rings included in the bottles. Remove the protective caps from the sensor tips. Store the protective caps inside the controller enclosure for future use when winterizing or reshipping.

Attach the pH and ORP sensor BNC connectors to the controller (see the Panel Features diagram).

Remove the compression fitting nuts from the flow cell assembly and slide them onto the sensors. Insert the sensors through the o-rings and into the compression fittings on the flow cell until the sensor tips are below the water line in the pipe. Hand tighten the nuts of the fittings. **Do not use a wrench.**

Make sure the controller power switch is OFF. Plug the power cords from the pH and ORP feeders into the controller.

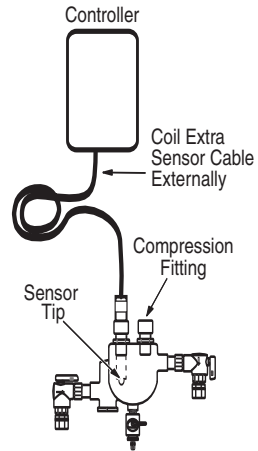

## Flow Switch

The flow switch plugs into the RCA jack on the base of the module (see the Panel Features diagram).

## Dip Switches

Dip switches 1 through 4 can be adjusted as desired. Access the switches from the back of the controller board.

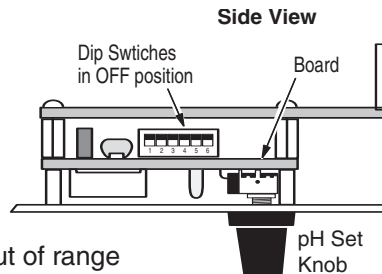

- #1 ON = No ORP feed if pH is out of range  
OFF = ORP feed regardless of the pH
- #2 ON = No ORP feed while the pH is feeding  
OFF = ORP and pH can feed simultaneously
- #3 OFF = ACID Feed, ON = BASE Feed
- #4 OFF = Lockout Disabled - Any changes possible  
ON = Lockout Enable - Calibration only

# System Startup

Do not add chemicals to the feeders until completing the following start-up procedures.

Prior to starting the system, use a DPD test kit to test the pool chemistry. Manually adjust and balance the pool to acceptable ranges. Automation should be used to maintain chemical levels, not to balance a pool.

Plug the controller power cord into the GFCI receptacle.

- With the controller selector knob in the **OFF** position turn the filter pump on and check for leaks in the system, and flow through the flow cell.
- Turn the selection knob to the **MANUAL** position. A slight turn of each set knob will activate the respective feeder. If the controller has not been programmed, it will be in the continuous mode and each feeder will activate for 30 seconds. If the feeders do not activate, find and correct the problem.
- When the selector knob is turned to **AUTOMATIC**, the green flow light, and the ORP and pH digital displays will come on. Once initiated, the controller has a 15-second delay to avoid unnecessary feeding. During the delay, bars will show in the digital readout.

**If the system has insufficient flow or pressure, the flow light will not light and the controller will not feed.**

- When the controller is initially powered up, the Default Settings discussed earlier will take effect; the ORP setting will be 650mV and the pH setting will be 7.5.
- Do an initial calibration of the pH reading. Always calibrate using water from the sample port of the flow cell, unless using preset buffer solution. It may take up to 24 hours before the sensors acclimate to the system so recalibrate 24 hours after the first calibration.

The pH sensor can drift slightly over time and calibration will offset this drift. **The pH sensor should be calibrated every four to six weeks.**

You are now ready to set the following functions:

- Feed set
- High and low alerts
- Feed times and delays (If not in continuous mode)
- Overfeed (If in continuous mode)

## pH Level Settings

1. Turn the selector knob to the **FEED SET** mode, then adjust the pH set knob until the desired pH level appears in the display. Acceptable levels are 7.2 to 7.8.
2. Adjust the pH feed system for a feed rate that is not too low or too high. Be aware of the lag time between the beginning of the chemical feed cycle and the sensor detection of the chemical levels after circulation through the pool or spa. A low feed rate can either cause the feeder to lag or the feeding to be extended. A high feed rate can result in too much pH being added.

To check the feed rate, use a test kit to test the pH balance of the water immediately after a pH feed cycle ends. If the pH is high (above the preset point of the pH set point), the feed rate is too high.

**Note:** If feeding liquid (muriatic) acid, dilute the acid in the water to avoid overshooting the set point. The smaller the body of water, the greater the need to dilute the acid.

3. The green pH feed light will come on only when the controller activates the pH feed system. The light will not illuminate when the pH alert light is on (pH is below or above the alert settings). If using timed feed, the feed light will flash during the feed cycle and be constant during the delay cycle. In continuous feed, the light will flash while feeding.

To verify the feed mode, acid or base, set the desired pH above the pH indicated on the digital display. The feed light should come on if the controller is set for acid feed. If set for base feed, the light will come on when the desired pH is set below the pH shown on the display.

## Sanitizer Settings

This controller displays direct ORP readings and the control is based on this reading, not the ppm (parts per million). While ORP indicates the effectiveness of the sanitizer, it does not directly correlate to a ppm reading. Use a DPD test kit to measure the free chlorine. If you need more sanitizer than that indicated by the ORP display, set the desired level above that point. If you require less sanitizer, set it below. **Note:** The ORP reading is not linear. An adjustment from 700 to 750 mV could increase the sanitizer level by several ppm.

1. Verify that the selector knob is in the **FEED SET** mode, adjust the ORP set knob until the desired level appears in the ORP display. The World Health Organization suggests maintaining an ORP at or above 650 mV. This is a good starting point.
2. Allow the system to operate for 24 hours. With the filtration system running, retest for the sanitizer level and adjust the ORP set knob if necessary.
3. The feed rate of the sanitizer should be adjusted in the same manner as the pH feeder.
4. The yellow ORP feed light will come on only when the controller is activating the ORP feed system. If using timed feed/delay, the feed light will flash during the feed cycle and remain on constantly during the delay cycle. In constant feed, the feed light will flash when feeding.

# Operation and Maintenance

The ORP feed light will come on to indicate when sanitizer is being dispensed. The pH feed light will light to indicate when pH is being dispensed.

When the system is feeding, the digital display may register an inaccurate sanitizer or pH level because the system is still circulating a dose of chemical. Reference the readings when the system is not feeding.

## Out-of-Range Alerts

The ORP alert light will flash when the ORP has been out-of-range for ten consecutive minutes. Once the alert light comes on, the controller will stop activating the feeder.

The pH alert light will flash when the pH has been out-of-range for ten consecutive minutes. Once the alert light comes on, the controller will stop activating the feeder.

When the out-of-range condition has been corrected, the controller will reactivate automatically. After a one-minute delay, it will activate the feeders, if necessary.

## Cleaning the Sensor Tips

It is important to keep the sensor tips clean to assure accurate readings. When the sensor tips become dirty, the sensors can read a lower than actual sanitizer/pH level and can cause too much chemical to be dispensed. **Note:** A sensor tip coated with calcium scale will not look visibly dirty.

As a general rule, the sensor tips should be cleaned every two to four weeks for commercial pools and spas, and once each month for residential. Cleaning frequency, however, can vary from one body of water to another.

To determine the appropriate frequency, note the reading prior to cleaning. After cleaning the sensor, allow a stabilizing period of approximately ten minutes. If the reading is identical to the reading prior to cleaning, the sensor was not dirty and the time between sensor cleanings can be increased.

To clean the sensor tip:

1. Turn off the controller. Loosen the compression fitting nut and gently remove the sensor from the flow cell assembly.
2. Swirl the tip for five seconds in muriatic acid (diluted 5 to 1) or white vinegar, and rinse it in water. **Do not touch, wipe or brush the end of the sensor.**

For commercial pools and spas, every third cleaning, swirl the sensor tip in a solution of liquid soap and water. Rinse with water.

3. Gently replace the sensor in the flow cell assembly and turn on the controller.
4. Allow the controller to operate for a few minutes to get an accurate reading. Adjust the set knobs if necessary.

## Checking the ORP Sensor

1. The ORP sensor should be checked every six months or anytime the feeder oversanitizes the water.
2. Clean the sensor tip as noted above.
3. Place the sensor in a clean glass of tap water. This should give a reading of between 200 and 400 mV. Adding a pinch of Dichlor or Trichlor should cause the ORP level to jump to between 750 and 800 mV. If Dichlor or Trichlor are not available and a sanitizer with a high pH such as calcium hypochlorite or liquid chlorine (sodium hypochlorite) is used, the ORP level may only rise to between 650 and 750 mV.
4. If the sensor does not respond as indicated, the sensor should be replaced.

## Checking the pH Sensor

1. The pH sensor should be checked every six months or anytime the pH goes out of range.
2. Place the sensor in a clean glass of tap water. Add a small amount of acid to the water. The pH reading should drop to the lowest red light. Then place the sensor in any solution with a pH above 7.5. The pH reading should move up.

3. If the sensor does not respond as indicated, the sensor should be replaced.

## Winterizing

If the system is subject to extended shutdowns or is located in colder climates, it is important to winterize the system.

1. Turn off the main power to the controller.
2. Loosen the compression fitting nuts and gently remove the sensors from the flow cell assembly. **The sensor tips must be stored in a protective cap or bottle filled with a solution of one teaspoon salt and three teaspoons water.** Mix the solution thoroughly and make sure the solution completely covers the tip of the sensors. **STORE THE SENSORS IN A WARM PLACE – DO NOT EXPOSE SENSORS TO FREEZING TEMPERATURES.**
3. Drain the water from the flow cell/flow switch assembly.



# Troubleshooting

PROBLEM	POSSIBLE CAUSE	SOLUTION
SANITIZER LEVEL TOO LOW	Set knob set too low	Adjust knob clockwise until the proper sanitizer level is reached and stabilized
	pH level too low (less than 7.2)	Check pH level with a test kit and adjust as required
	Chemical feeder empty	Refill chemical feeder
	Sensor failure	Check sensor
SANITIZER LEVEL TOO HIGH	Sensor dirty	Clean sensor
	Set knob set too high	Test sanitizer level with a test kit and adjust the ORP knob counterclockwise until the proper sanitizer level is reached
	pH too high (above 7.8)	Check pH level with a test kit and adjust as necessary
pH LEVEL TOO LOW	Set knob set too low	Adjust pH set knob
	pH calibrate knob improperly adjusted	Adjust pH calibrate knob
	Chemical feed rate too high	Lower feed rate
	Chemical feeder empty (if using base)	Refill chemical feeder
	Sensor failure	Check sensor
pH LEVEL TOO HIGH	Sensor dirty	Clean sensor
	pH sensor calibration improperly adjusted	Adjust pH sensor calibration
	pH set knob set too high	Adjust knob counterclockwise
	Chemical feeder empty (if using acid)	Refill chemical feeder
	Feed pump malfunction	Repair feeder pump
	Chemical feed rate too low	Increase feed rate
RED pH ALERT LIGHT ON	pH level is below 7.0 or above 8.2	Manually adjust pH in the pool
DISPLAY LIGHTS OFF	No power supply	Check circuit breaker
FEEDER DOES NOT OPERATE	Bad fuse	Replace output fuse
MANUAL FEED DOES NOT FEED	Flow switch problem	Unplug flow cell, press MANUAL FEED again. If feeder is activated, replace flow switch

# Guidelines for Using ORP for Water Maintenance

- Q. Why should I maintain a pH level between 7.2 and 7.8?
- A. pH levels below 7.0 can cause eye irritation, metal corrosion, etching of plaster, stains, damage to vinyl liners, and loss of sanitizer. In addition to eye irritation, pH levels above 8.0 can cause cloudy water, scale formation and loss of sanitizer efficiency (low ORP).
- Q. How do I increase the pH level?
- A. Small amounts of basic (alkaline) chemicals such as pH Plus or pH Up can be added.
- Q. How do I lower the pH level?
- A. Small amounts of liquid acid (muriatic) or dry acid (sodium bisulfate) such as pH Minus or pH Down can be added.
- Q. How does 650 mV relate to the ppm of chlorine?
- A. Pure water, without conditioner, at a pH level of 7.5 corresponds to approximately 1.5 ppm of chlorine. Actual pool or spa water usually takes at least 1-2 ppm of chlorine to generate 650 mV ORP, although the Total Dissolved Solids and pH can affect the activity of the chlorine and thus change the level of ORP.
- Q. Does an ORP of 650 mV stop algae?
- A. No. Because algae is a living organism that adapts genetically to a constant level of sanitizer, the periodic addition of an algaecide or shocking may be necessary. Please note that the addition of some chemicals can change the ORP readings for up to several days.
- Q. What causes a low ORP?
- A. A low sanitizer level, a pH level above 8.0, a conditioner level above 200 ppm or a TDS (Total Dissolved Solids) above 3,000 ppm can all cause a low ORP.

- Q. How do I make sure the ORP sensor is working properly?
- A. Watch the sensor reading when adding sanitizer. If it does not respond properly, follow the recommended sensor tip cleaning procedures detailed in the Maintenance section. If cleaning does not solve the problem, check the sensor as outlined in Maintenance.
- Q. How should the ORP sensor respond to adding acid?
- A. Adding acid decreases the pH level thus increasing the ORP.
- Q. How should the ORP sensor respond to adding base?
- A. Adding base increases the pH level thus decreasing the ORP.
- Q. How should the ORP sensor respond to adding sanitizer?
- A. Depending upon the type of sanitizer used, the ORP should increase. A sanitizer high in base, such as liquid chlorine (sodium hypochlorite) or a dry chlorine powder (calcium hypochlorite), however, can cause the pH level to rise and the ORP to decrease. The pH level must be in the ideal range to maintain the proper ORP level.
- Q. Can ORP be used with ozone?
- A. Even though ozone is an excellent oxidizer, it has a very short lifetime. Therefore, a chlorine or bromine residual will still be needed in order to maintain the proper ORP level. When using ozone, the ozone must be introduced into the system downstream from the sensors.
- Q. Can ORP be used with UV or metal ions?
- A. Only if the proper chlorine or bromine residual is maintained.

# Warranty

## **Polaris Watermatic C660 ORP/pH Controller**

This limited warranty is extended to the original consumer purchaser of this Polaris Watermatic C660 Controller manufactured by Zodiac Pool Care, Inc. ("Zodiac"), 2620 Commerce Way, Vista, CA 92081-8438, USA.

Zodiac warrants the Watermatic Controller it manufactures, including all parts and components thereof, to be free of defects in material and workmanship. For questions regarding your Polaris Watermatic Controller, please feel free to call or write us. Be sure to provide the serial number of your unit.

The warranty commences on the date of installation of the controller and shall remain in effect for a period of one (1) year, but in no event shall it be in effect for more than two (2) years from the date of manufacture of the controller as established by the serial number.

This limited warranty does not apply if the failure is caused or contributed by any of the following: improper handling, improper storage, abuse, unsuitable application of the unit, lack of reasonable and necessary maintenance, winter freezing or repairs made or attempted by other than Zodiac or one of its authorized service centers. Zodiac will repair or replace, at its option, a unit or part proved to be defective within the warranty period and under the conditions of the warranty.

Unless local repair is authorized, the consumer must deliver or ship the unit or the warranty parts, freight prepaid to the nearest Polaris Authorized Service Center or return it freight prepaid (after proper authorization) to the plant of manufacture.

Authorization to return a unit to the plant of manufacture must be obtained from the Zodiac Customer Service Department. For your convenience, please check with your dealer for the local procedure before exercising this warranty. If further directions or instructions should be required, contact the Customer Service

Department at 1-800-822-7933 (USA and Canada only) or 760-599-9600. Be sure to insure your shipments against loss or damage during transit.

Zodiac is not responsible for the cost of removal of the unit, damages due to removal, any other expenses incurred in shipping the unit or parts to or from the factory or its authorized service centers, the installation of the repaired or replacement unit. The consumer must bear these expenses.

This warranty does not cover repair or replacement of a unit except at our factory or a Polaris Authorized Service Center.

THIS LIMITED WARRANTY IS IN LIEU OF ALL OTHER WARRANTIES, EXPRESS OR IMPLIED, INCLUDING THE IMPLIED WARRANTIES OF MERCHANTABILITY AND FITNESS FOR A PARTICULAR PURPOSE, AND ALL SUCH OTHER WARRANTIES ARE DISCLAIMED EXCEPT TO THE EXTENT ANY IMPLIED WARRANTY MAY BE IMPOSED BY STATE CONSUMER LAW. ANY SUCH IMPLIED WARRANTY IMPOSED BY STATE CONSUMER LAW IS LIMITED IN DURATION TO ONE (1) YEAR FROM DATE OF PURCHASE.

IN NO EVENT SHALL ZODIAC BE LIABLE FOR INCIDENTAL OR CONSEQUENTIAL DAMAGES OF ANY NATURE OR KIND OR FOR DAMAGES TO PERSONS OR PROPERTY, INCLUDING ANY DAMAGE RESULTING FROM THE USE OF THE POLARIS WATERMATIC CONTROLLER.

Some states do not allow limitations on how long an implied warranty lasts, or the exclusion or limitation of incidental or consequential damages, so the above limitations may not apply to you.

This limited warranty is valid only in the United States of America and Canada, and it does not apply to Polaris Watermatic Controllers sold or installed in any other country.

# Appendix

For most controller applications, the continuous feed mode is appropriate. However, if you are using the controller in one of the following situations, the settings will need to be changed to allow for a timed-feed cycle followed by a delay.

- **Using a peristaltic pump to feed the sanitizer or pH, and you are experiencing overfeeding.**

A peristaltic pump feeds slowly and sometimes the sanitizer or pH feeder may overfeed due to the delay in the circulation of the chemicals. The same thing can occur in pools where the equipment is located at a distance.

Set a short feed cycle (a few minutes) followed by a longer delay. Exact settings will depend on the size of the body of water. If spiking continues, shorten the Feed Time and/or increase the Delay.

Remember, when using acid in small bodies of water, the acid must be diluted.

- **Using an erosion feeder in a spa or small body of water, and you are experiencing spiking.**

Erosion feed systems continue to dissolve sanitizer while in the Off mode. This can be problematic in small bodies of water. It is best to set a very short feed cycle followed by a delay that allows the sanitizer to circulate past the sensors.

Start with: 10 sec. Feed Time, 5 min. Delay

- **In an application where the ORP sensor is located downstream from the introduction of the sanitizer.**

With this type of installation, there is a potential for the sensor readings to be inaccurate. Since this application is generally associated with sanitizer tablets, which dissolve slowly, it is best to set a long feed cycle followed by a delay that allows the sanitizer to circulate past the sensor.

Start with: 10 min. Feed Time, 5 min. Delay

- **Using the controller with a Watermatic G1000 or G7500 feeder.**

These feeders can only operate with a short feed cycle followed by a delay. Continuous or long feed cycles will damage the feeders. In all cases, the two-ounce cone must be used.

For pools set:

Sanitizer: 4.8 second Feed Time, 10 minute Delay

pH: 0.6 second Feed Time, 5 minute Delay

For spas set:

Sanitizer: 0.6 second Feed Time, 5 minute Delay

pH: 0.6 second Feed Time, 5 minute Delay

Once the appropriate feed and delay cycle times have been set, allow the system to run for a few days. Reevaluate and adjust the feed cycle longer if the water is undersanitized or shorter if the water is oversanitized. The delay cycle can also be shortened if the feeder cannot keep up with the demand.

The ORP and pH sides of the controller can be modified independently. For example, the pH side can be left in continuous mode while the ORP side is set for a timed feed, and vice versa. This versatility enables you to choose the optimal settings for the application.



**Your pool. Our reputation.**

2620 Commerce Way, Vista, CA 92081-8438 • 760-599-9600 • 1-800-822-7933

[www.polarispool.com](http://www.polarispool.com)