

4

3

2

1

REV	ECO	REV BY	DATE	APPD	DATE
R	0025329	I.MATA	04-11-2012	R.RASCON	04-11-2012

CUSTOMER IS SOLEY RESPONSIBLE FOR MOTOR PERFORMANCE AND SUITABILITY IN APPLICATIONS FOR CUSTOMER'S USES

GPR	FRAME	C	(BS)	(XA)	(XG)	(XH)	(XN)	SHELL LENGTH
01	R56Y	13.37[339.6]	7.81[198.4]	2.27[57.7]	3.48[88.4]	5.30[134.6]	5.50[139.7]	8.75[223.0]
02	X56Y	12.12[307.8]	6.56[166.6]	2.01[51.1]	2.48[63.0]	5.06[128.5]	5.20[132.1]	7.50[190.5]
03	P56Y	12.62[320.5]	7.06[179.3]	2.27[57.7]	2.73[69.3]	5.30[134.6]	5.50[139.7]	8.00[203.2]
04	N56Y	11.87[301.5]	6.31[160.3]	2.01[51.1]	2.22[56.4]	5.06[128.5]	5.20[132.1]	7.25[184.2]
05	L56Y	10.87[276.1]	5.31[134.9]	2.01[51.1]	1.22[30.1]	5.06[128.5]	5.20[132.1]	6.25[158.8]
06	U56Y	11.62[295.1]	6.06[153.9]	2.27[57.7]	1.73[44.0]	5.30[134.6]	5.20[132.1]	7.00[177.8]
07	Y56Y	11.25[285.8]	5.69[144.5]	2.01[51.1]	1.60[40.7]	5.06[128.5]	5.20[132.1]	6.63[168.4]

NOTES:

- ALL DIMENSIONS SHOWN IN PARENTHESIS ARE REFERENCE DIMENSIONS. ALL OTHER DIMENSIONS ARE TOLERANCED PER THE FOLLOWING CHART UNLESS OTHERWISE SPECIFIED.
 - "C" DIM. = ±.005[.13]
 - SHAFT EXT. = ±.034[.86]
 - LEAD LENGTHS EXTENDED = ±1.00[25.4]
 - THRU-BOLTS = ±.050[1.27]
- SHAFT RUNOUT NOT TO EXTEND .002[.05] T.I.R.

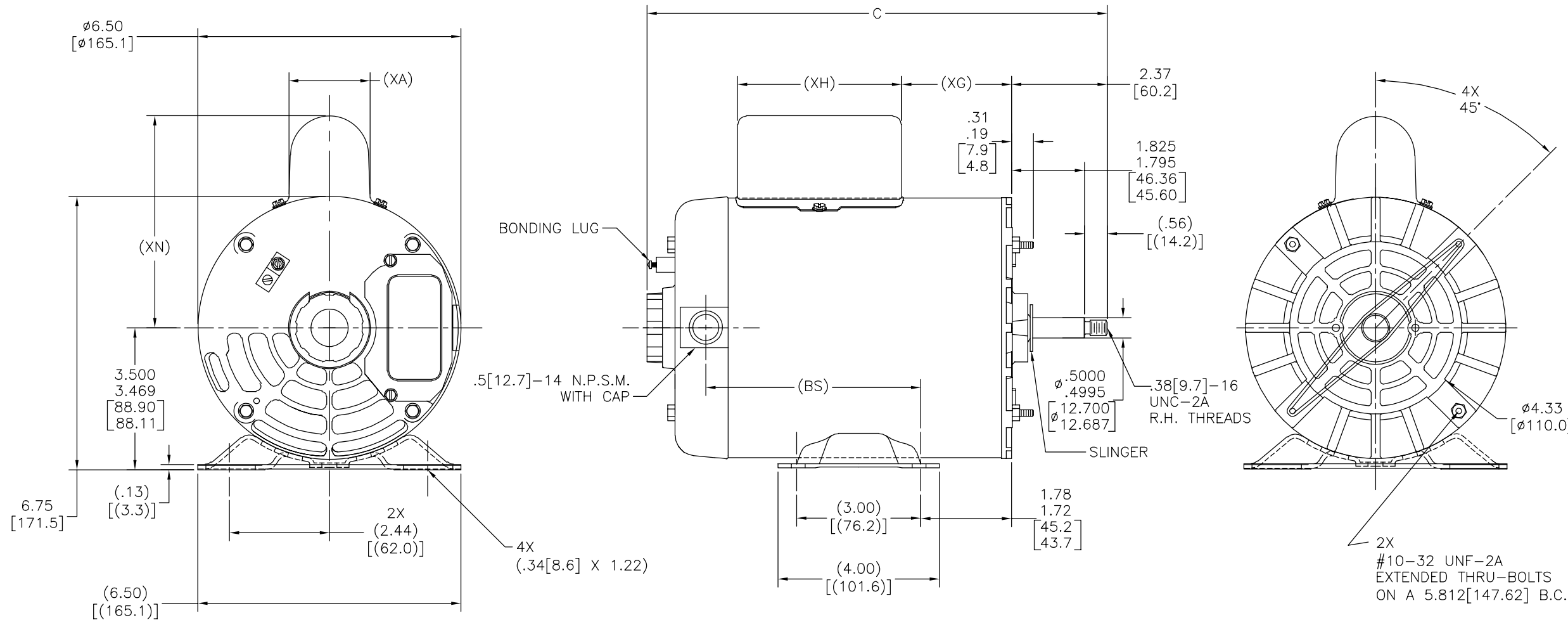

GEOMETRIC CHARACTERISTICS & SYMBOLS

- FLATNESS
- STRAIGHTNESS
- ∠ ANGULARITY
- ⊥ PERPENDICULARITY (SQUARENESS)
- ∥ PARALLELISM
- ROUNDNESS (CIRCULARITY)
- ⊘ CYLINDRICITY
- △ PROFILE OF ANY SURFACE
- ∩ PROFILE OF ANY LINE
- ↗ RUNOUT
- ⊕ TRUE POSITION
- ⊙ CONCENTRICITY
- ≡ SYMMETRY

ASME Y14.5M 1994

UNLESS OTHERWISE SPECIFIED DIM. TOLERANCES ARE AS FOLLOWS:

INCH	±.1	±.02	±.005	±.0005
mm	±0.5	±0.13	±0.013	

ANG. ±.50 DEG
REMOVE BURRS & BREAK SHARP EDGES:
INCH .003-.015 mm 0.1-0.4
CORNER FILLETS TO:
INCH .020 mm 0.5
MACHINE SURFACES:
INCH 125 mm 3.2

METRIC DIMS. SHOWN IN [BRACKETS]

DR BY:	BLP	03-10-1997
APPD:	SAS	03-13-1997
THIRD ANGLE PROJECTION		EDS DATE 11-11-2011 FORMAT REV G
CONFIDENTIAL: THIS DRAWING AND ITS INFORMATION ARE THE EXCLUSIVE AND CONFIDENTIAL PROPERTY OF REGAL-BELOIT CORPORATION AND ARE NOT TO BE DISCLOSED, DUPLICATED, DISTRIBUTED OR OTHERWISE USED WITHOUT THE WRITTEN CONSENT OF REGAL-BELOIT CORPORATION. -ALL RIGHTS RESERVED.		

DESCRIPTION OUTLINE	
SIZE C	DWG NO 188610
SCALE NONE	SHEET 1

4

3

2

1

REVISION:	ECO	REVISADO POR:	FECHA:	APROBADO POR:	FECHA:
R	0025329	I.MATA	04-11-2012	R.RASCON	04-11-2012

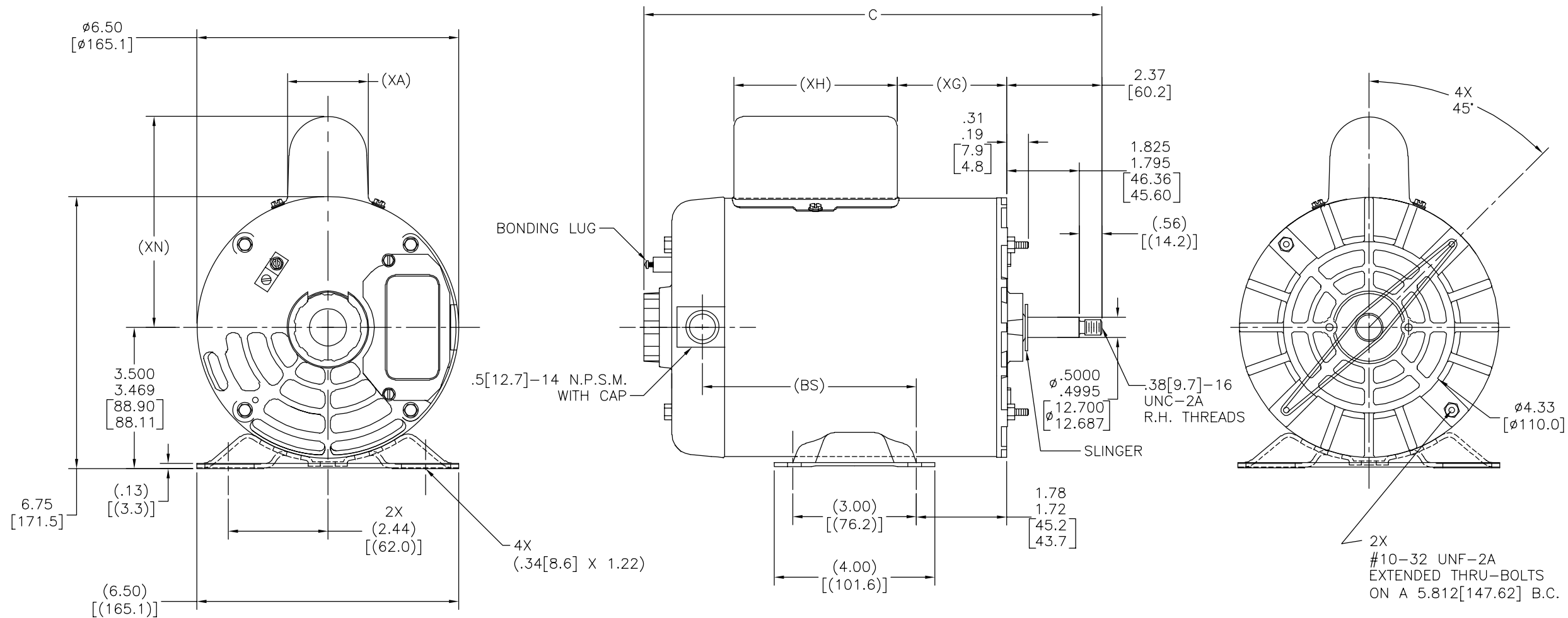

CARACTERISTICAS DE GEOMETRIA Y SIMBOLOS

- PLANICIDAD
- RECTITUD
- ∠ ANGULARIDAD
- ⊥ PERPENDICULARIDAD (A ESCUADRA)
- // PARALELISMO
- REDONDEZ (CIRCULARIDAD)
- ∅ CILINDRICIDAD
- △ PERFIL DE CUALQUIER SUPERFICIE
- ∧ PERFIL DE CUALQUIER LINEA
- ∧ VARIACION
- ⊕ POSICION REAL
- ⊙ CONCENTRICIDAD
- = SIMETRIA

ASME Y14.5M 1994

A MENOS QUE SE ESPECIFIQUE DE OTRA MANERA, LAS TOLERANCIAS DE LAS DIMS; SON LAS SIGUIENTES:

	PULG	±.1	±.02	±.005	±.0005
	mm	±0.5	±0.13	±0.013	

ANG. ±.50 GRADOS
ELIMINAR REBABAS Y ORILLAS FILOSAS DEL BORDE.
PULG .003-.015 mm 0.1-0.4
FILETEAR ESQUINA: PULG .020 mm 0.5
MAQUINAR SUPERFICIES
PULG 125 mm .32

DIMS METRICAS MOSTRADAS [PARENTESIS]

DIBUJADO POR:	BLP	03-10-1997
APROBADO POR:	SAS	03-13-1997
TERCER ANGULO DE PROYECCION	⊕	FECHA EDS: 11-11-2011 REV. FORMATO: G
CONFIDENCIAL: ESTE DIBUJO Y SU INFORMACION SON PROPIEDAD DE USO EXCLUSIVO Y CONFIDENCIAL DE REGAL-BELOIT CORPORATION. Y NO DEBERAN SER REVELADOS, DUPLICADOS, DISTRIBUIDOS O USARSE DE OTRA MANERA SIN EL CONSENTIMIENTO ESCRITO DE REGAL-BELOIT CORPORATION. -TODOS LOS DERECHOS RESERVADOS.		

DESCRIPCION: OUTLINE	
TAMAÑO: C	NUMERO DE DIBUJO: 188610
ESCALA: NONE	HOJA: 1

版本	ECO	编制	日期	批准	日期
R	0025329	I.MATA	04-11-2012	R.RASCON	04-11-2012

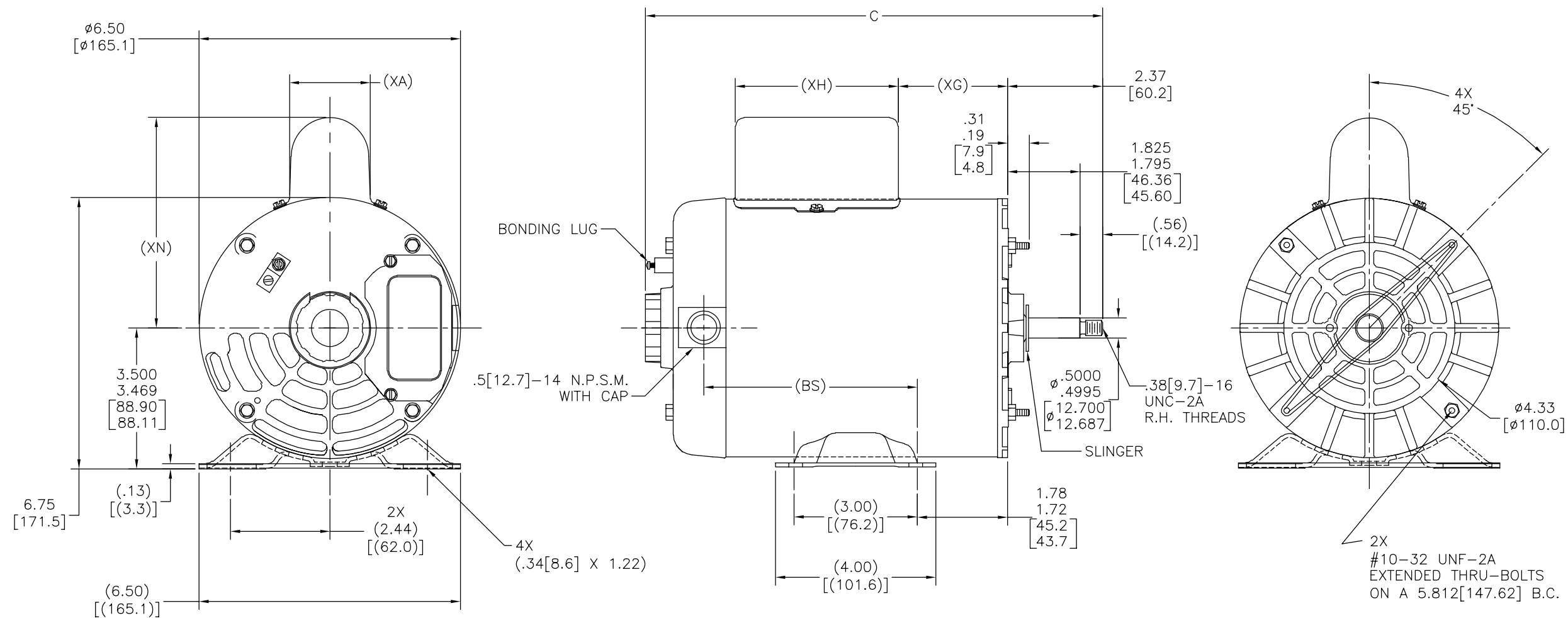

形位公差	除另有注明
□ 平面度	尺寸公差如下:
— 直线度	英寸 X XX XXX XXXX
∠ 倾斜度	英寸 ±.1 ±.02 ±.005 ±.0005
⊥ 垂直度	毫米 ±0.5 ±0.13 ±0.013
// 平行度	角度 ±.50 度
○ 圆度	清理毛刺和尖棱
⊘ 圆柱度	英寸 .003-.015 毫米 0.1-0.4
△ 面轮廓度	内圆角
∩ 线轮廓度	英寸 .020 毫米 0.5
↗ 圆跳动	表面粗糙度
⊕ 位置度	英制 125 米制 3.2
⊙ 同轴度	米制尺寸显示在 []

ASME Y14.5M 1994

绘图:	BLP	03-10-1997
批准:	SAS	03-13-1997
第三角投影		图纸格式发布日期 11-11-2011 图纸格式版本 G
机密: 本图纸及相关信息所有权归REGAL-BELOIT CORPORATION 未经REGAL-BELOIT CORPORATION书面授权, 不得泄露、 复制、传播或作其他用途。—版权所有		

名称	OUTLINE
图幅	C
图号	188610
比例	NONE
页号	1