



POOL & SPA HEAT PUMP



- 118k BTU Heat Only
- Easy Handling And Installation
- Serviceable Design
- Quiet Operation
- Dependable Performance
- Powder-Coated Steel Cabinet
- Simple Digital Controls
- Easy-To-Read Service Codes
- Standard Warranty

Model	TWPH-6560EHT01
Model Type	Heat Only
Max. Capacity (BTUH)	118,000
C.O.P	6.0
Rated Flow Capacity (GPM)	49.5
Indoor/Outdoor	Outdoor
Residential/Commercial	Residential
Heat Exchanger Material	Titanium
Refrigerant Type	R410A
Heating Capacity (kW)	34.5
Rated Outlet Water Temp	104F
Fan Type	1-speed, 1-Ph/60Hz/240V motor, 4 blade fan
Min. Water Supply Flow (GPM)	30
Max. Water Supply Flow (GPM)	60

Pool & Spa Heat Pump

Model TWPH-6560

WeatherKing's pool heat pump features several innovations that improve dependability and efficiency.

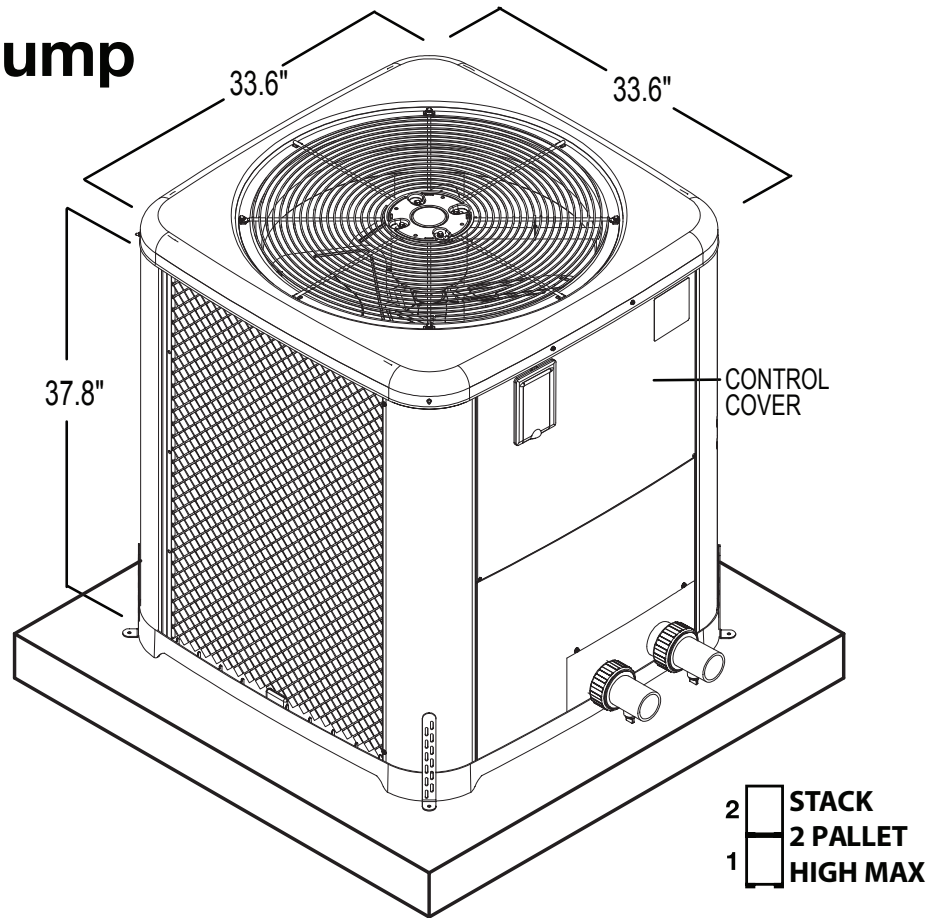

Heat Exchanger

Spiral Titanium Tube Heat Exchanger

Our spiral titanium tube heat exchanger provides a corrosion-free waterway that can withstand the abuses of harsh pool chemistry. The spiral tube helps reduce deposit build-up and increases efficiency by performing a "scoop-and-lift" action.

Plumbing Connections

Off-set 2" PVC union connections are included for ease of installation.

Evaporator Coil

Large Air Coils

Raised lanced-fin design maximizes heating at lower temperatures. From the proper fins per inch to advanced distribution circuiting, WeatherKing engineered coils are highly optimized to meet our specific design requirements.

Cabinet

Powder-Coated Steel Cabinet

Polyester powder-coated, non-corrosive cabinet is more durable than plastic heat pump cabinets.

Compressor

Scroll Compressor

Scroll compressors are quiet and efficient compared to piston type compressors. They provide higher efficiency, lower sound levels, superior durability and unsurpassed reliability. The unique design of a scroll compressor actually wears in over time, not out!

Sound Isolation Pads

Prevents sound transfer to equipment pad and elevates the base pan to improve water drainage.

Digital Controls

Pool/Spa Control

Your digital heat pump pool heater can be set to different target temperatures. Dial in just the right spa temperature and never have to adjust it again. The pool can be set to a lower, more energy saving temperature.

Remote Compatible

The digital heat pump pool heater can be easily controlled by most two-wire and three wire remote systems.

On Board Diagnostics

Tells the homeowner if there is a problem. Provides the service technician with detailed diagnostic information.

Warranty

Two years following the effective date for labor and seven years following the effective date for parts.

208-230VAC, 1-Ph, 60 Hz. Amps: 46min/70max
Uses R-410A refrigerant.

* Tested to AHRI 1160. Maximum water flow 30-60gpm.

** Shipping dimensions per unit 38.75" x 38.75" x 42.5" (L x W x H).



Tested to UL Standard 1261

weatherking.com/products/heat-pumps

2151 Eastman Avenue | Oxnard, CA 93030 | 805-278-5300
Litho in U.S.A. ©2024 Raypak, Inc.

WK-P-600-1 REV A
Effective 11-16-24 Replaces NEW