

SETUP AND SAFE USE OF THE HH1300, 1300X, HH1306, AND HH1307 MOUNT ASSEMBLY

NOTE: Your vehicle (or trailer) must have a 2" hitch receiver to use the complete mount assembly.

If you are not using the hitch adapter for trailer mounting, then U-bolt the Hammer-Head mount directly to the trailer wall in an area that can support the total weight sufficiently (approximately 130-140 lbs). The use of straps or braces from the trailer or vehicle to the top of the mount upright can provide additional support.

INSTRUCTIONS:

Bolt the hitch adapter to the mount upright using the included u-bolts so that the bottom of the mount upright will be at least 12-16 inches from the road surface. The cart wheels should be high enough so that they do not make contact with steep driveways or speed bumps. Do not set up with the cart tires rolling on the road.

The lower u-bolt can be placed under the lower u-channel if more height is needed or above if less height is needed. **ALWAYS USE BOTH U-BOLTS.**

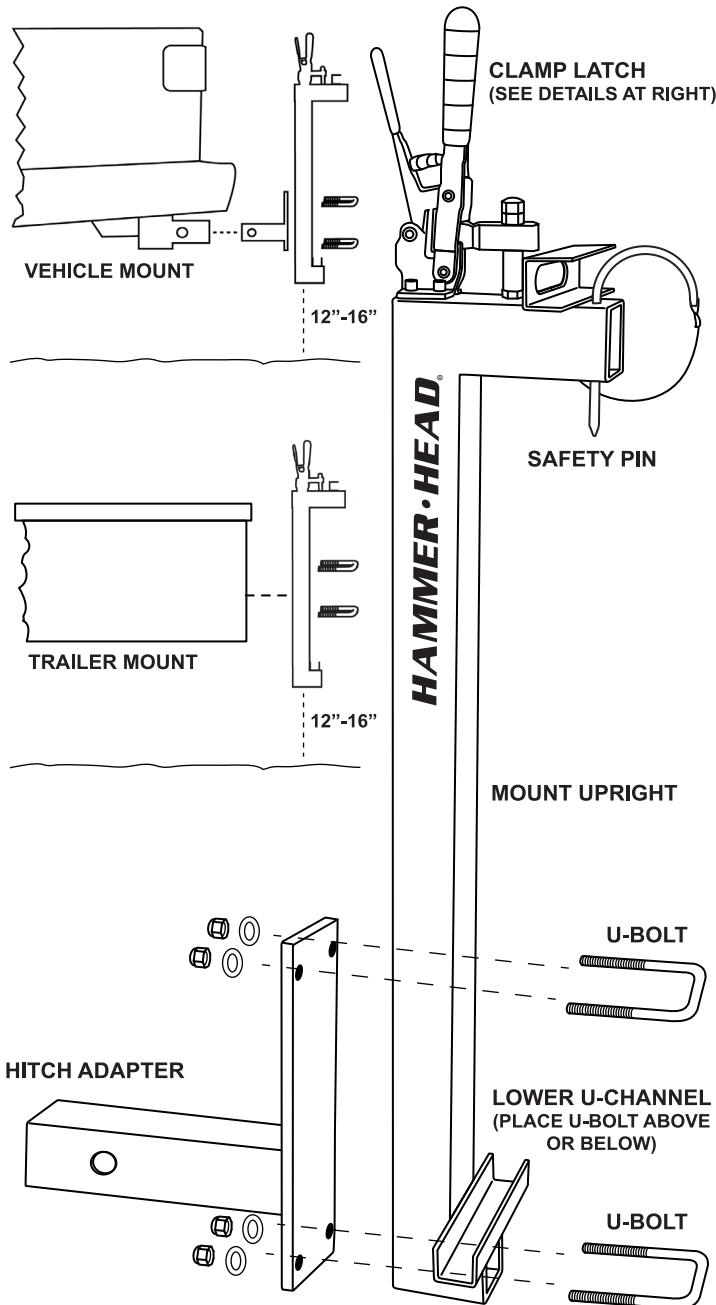

LATCH ADJUSTMENT DETAIL - RED HANDLE CLAMP

WARNING!

CHECK THESE FOUR SAFETY POINTS BEFORE USING THIS MOUNTING DEVICE:

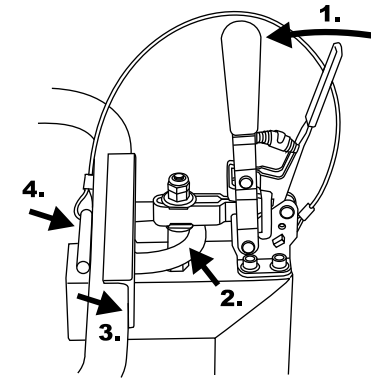

1. CLAMP LATCH MUST BE PUSHED COMPLETELY FORWARD UNTIL IT LOCKS INTO PLACE AND THE SPRING LEVER OPENS
2. BOTH NUTS ON THE LATCH BOLT MUST BE TIGHTENED DOWN AND THE BOLT PIN SHOULD MAKE CONTACT WITH CART MOUNT LOOP WHEN LATCHING
3. CART FRAME MUST MAKE CONTACT WITH MOUNT CHANNEL WHEN CLAMP IS LOCKED DOWN
4. ALWAYS USE THE SAFETY PIN

LATCH ADJUSTMENT DETAIL - BLACK T-HANDLE CLAMP

WARNING!

CHECK THESE THREE SAFETY POINTS BEFORE USING THIS MOUNTING DEVICE:

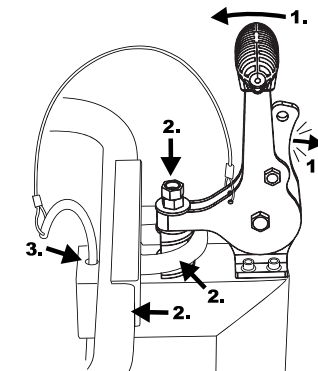

1. CLAMP LATCH MUST BE PUSHED COMPLETELY FORWARD UNTIL IT **CLICKS** INTO PLACE AND THE TRIGGER POPS OUT
2. BOTH NUTS ON THE LATCH BOLT MUST BE TIGHTENED SO THAT THE HALF CIRCLE BUSHING MAKES CONTACT WITH CART MOUNT LOOP AND THE CART FRAME MAKES CONTACT WITH THE MOUNT CHANNEL WHEN CLAMP IS LOCKED DOWN. THE HALF CIRCLE BUSHING SHOULD NOT MOVE AFTER TIGHTENING
3. ALWAYS USE THE SAFETY J-PIN

WARNING! WARNING! WARNING!

- Make sure to tighten all hardware sufficiently to avoid slippage.
- Check all hardware and mount components regularly for tightness, corrosion, and wear.
- Do not transport your Hammer-Head unit with chemicals in the accessory tray.
- Secure all loose items on your Hammer-Head unit before driving.

Refer to the clamp latch adjustment detail (at right) to properly adjust the clamp latch. **DO NOT USE THE CLAMP LATCH WITHOUT FIRST ADJUSTING THE AND INSPECTING ALL SAFETY POINTS (See details at right).**

THE OPERATOR ASSUMES ALL RESPONSIBILITY AND RISK ASSOCIATED WITH THE USE AND MAINTENANCE OF THIS DEVICE. FAILURE TO INSPECT THIS DEVICE FOR LOOSENESS OR WEAR BEFORE EACH USE COULD CAUSE SERIOUS ACCIDENT OR INJURY!