

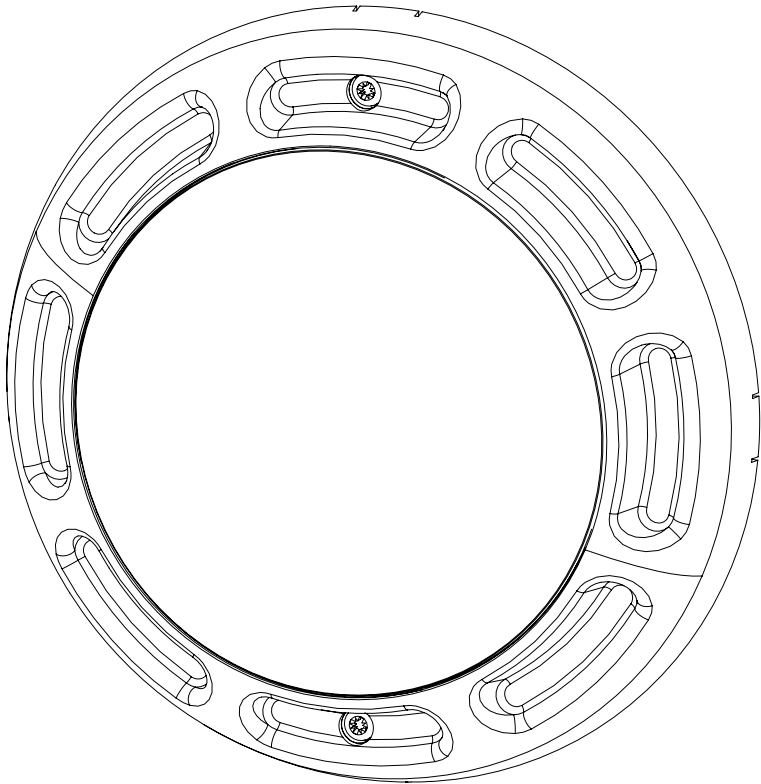

LIGHTING



EVENGLOW
NICHELESS INSTALLATION MANUAL

CONTENTS

PAGE	
2	Guides and Warnings
3	Nicheless Installation
6	Connecting Light
7	Connecting to driver
8	Troubleshooting
8	Terms and Conditions

GUIDES AND WARNINGS

Tools Required:

- 2 1/2" Hole Saw
- Silicon + caulking gun
- Thread tape

IMPORTANT INFORMATION:

- 1) Ensure that the electrical system for your pool conforms with all the requirements of the National Electrical Code (NEC) and all relevant local codes and ordinances.
- 2) This 12V Underwater Light must be installed in accordance with the National Electrical Code by a Certified Electrician or a Qualified Pool Technician. NOTE: No Bonding Terminal is required on the forming shell since the fixture is an all plastic construction and complies with NEC article 680 Requirements.
- 3) This Underwater light is designed for use with the PCR-4 AND PCR-2D UL Listed Class 2 LED Driver.

DO NOT CONNECT THIS 12V LIGHT DIRECT TO A 120V CIRCUIT.

The Junction Box and the low voltage transformer is located at least 4 (four) inches (10.16 cm) above ground level or eight (8) inches (20.3 cm) above maximum water level, whichever is higher. The Junction Box must be at least 48 inches (1.22 m) from the edge of the pool.

To be certain that the pool or spa electrical system meets all applicable requirements, the electrician should also consult the local building department.

CANADIAN INSTALLATION 1.5" WALL FITTING

Be sure the electrical system of your pool conforms with the following requirements of the Canadian Electrical Code (CE), and all local codes and ordinances. A licensed or certified electrician must install the electrical system to meet or exceed those requirements before the light and (fixture-housing) is installed.

DRY NICHE INSTALLATION

Drilling hole in fibreglass and vinyl pool

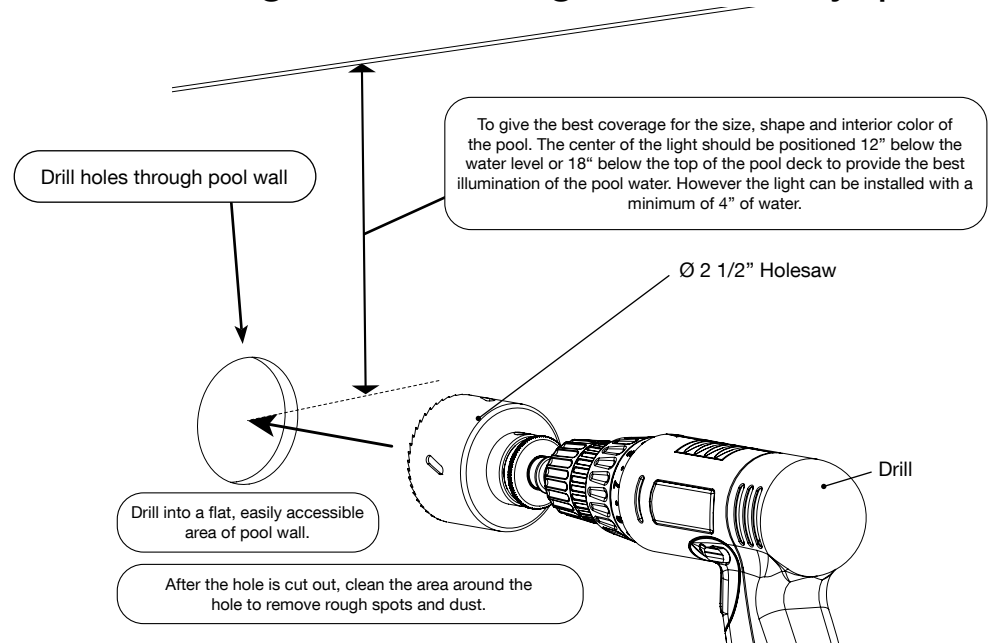

Sealing Dry Niche Light into 1.5" Fitting

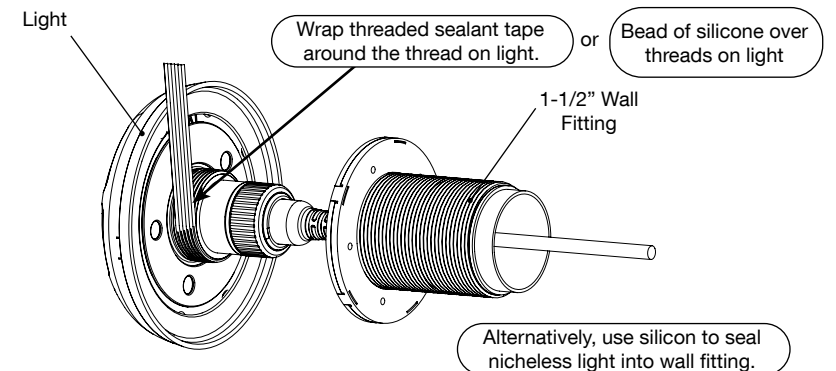

DRY NICHE INSTALLATION

Installation Setup - Concrete/Gunite

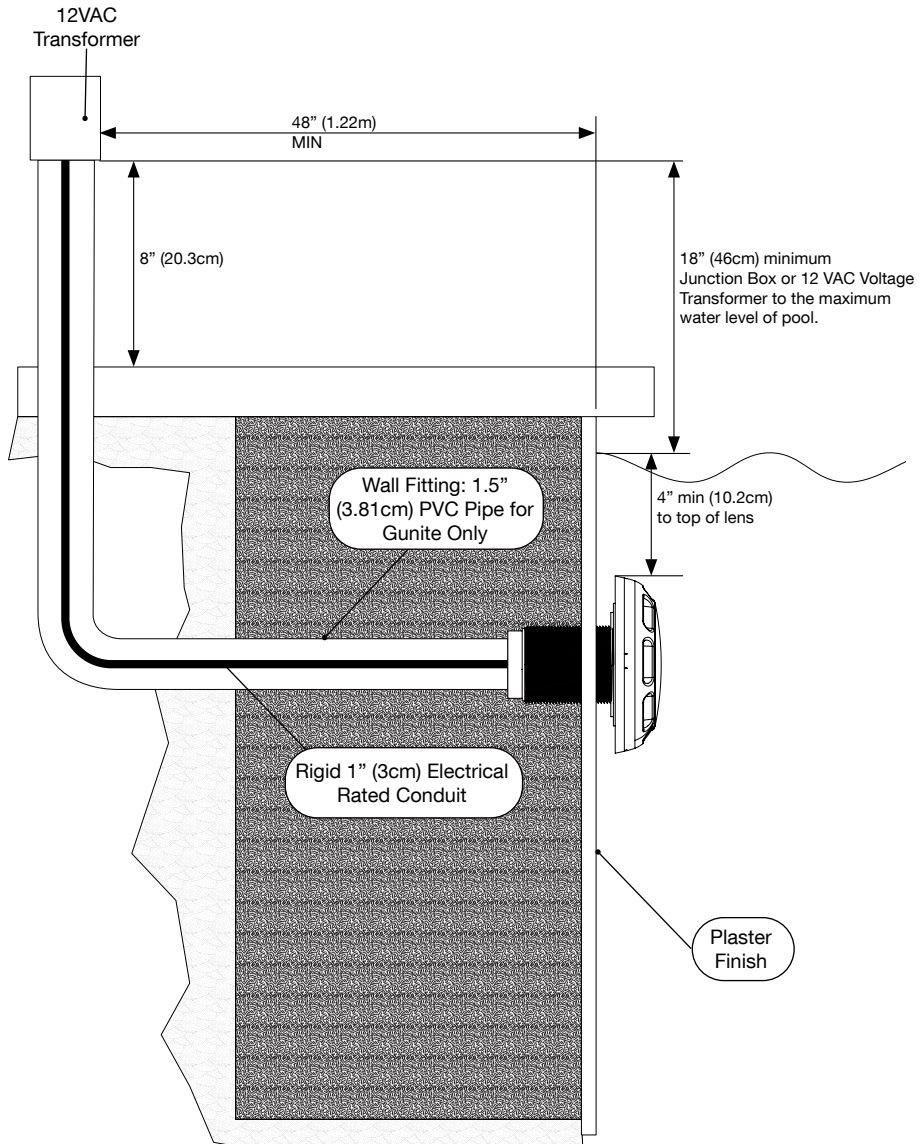

DRY NICHE INSTALLATION

Installation Setup - Fiberglass/Vinyl

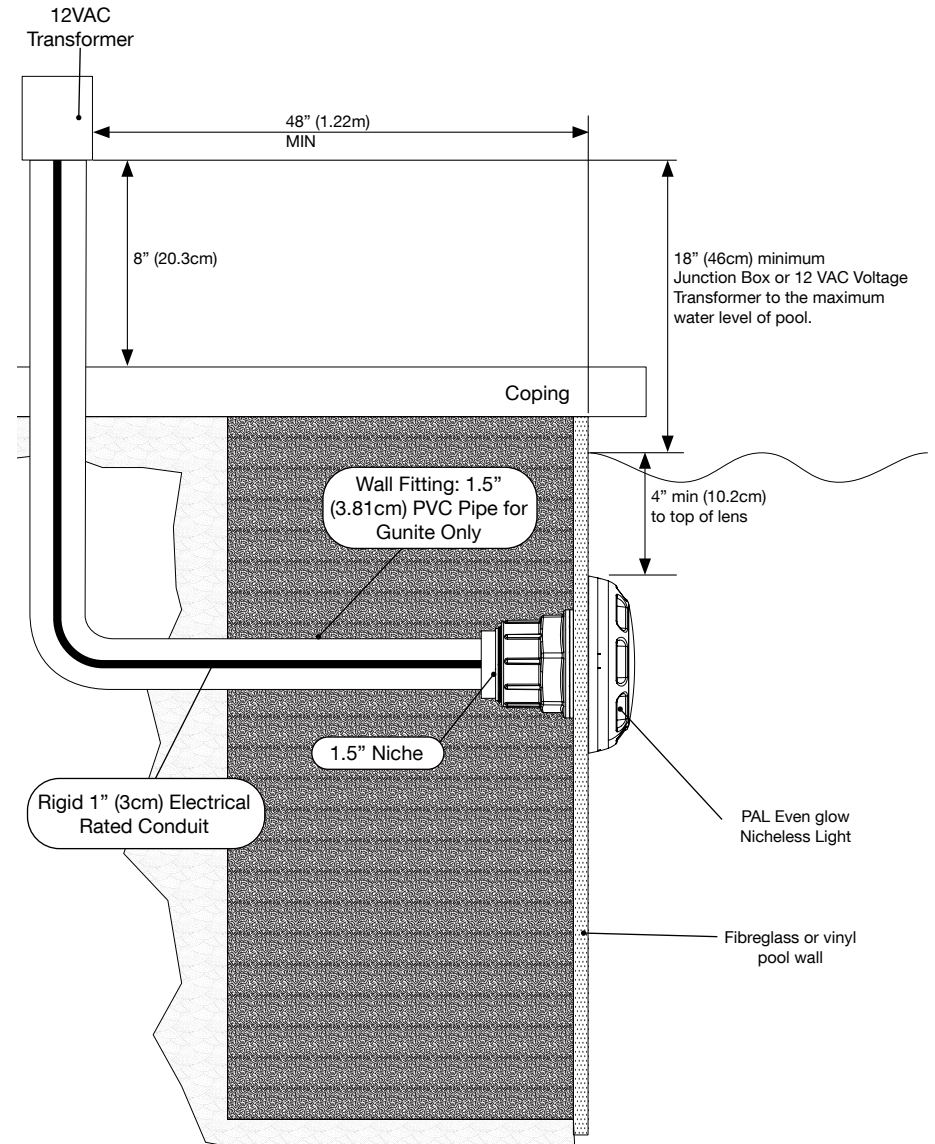

DRY NICHE INSTALLATION

Removing and Installing Light

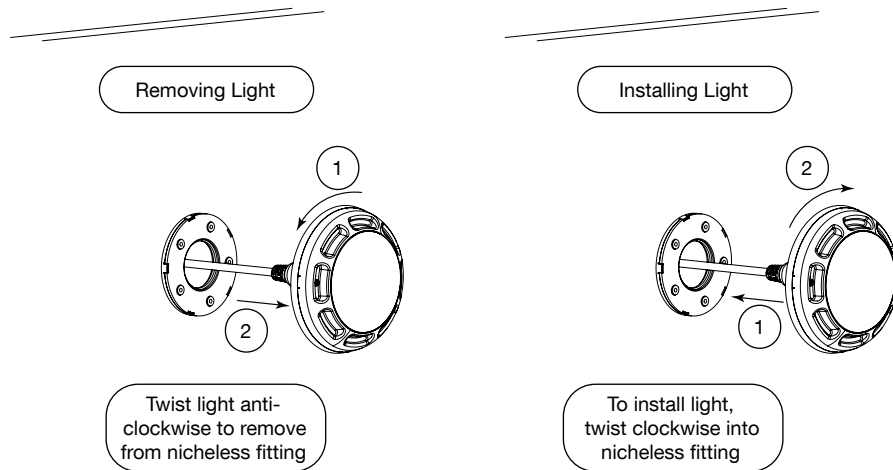

CONNECTING TO LIGHT

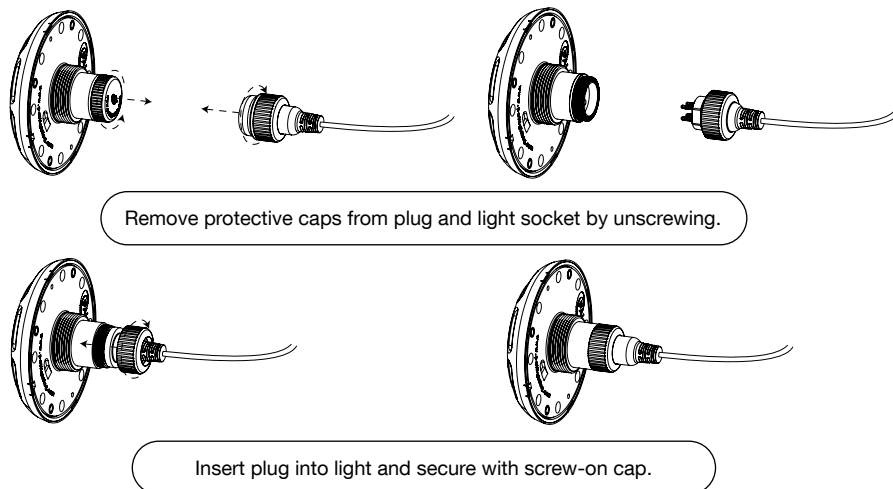

CONNECTING TO DRIVER

PAL COLOR TOUCH DRIVER

The PAL-EGN is powered by the PAL PCR-4 Class 2 LED Driver or PCR-2D that is controlled with the PCT-1 Wireless transmitter.

Refer to PCR-4 or PCR-2D for Detailed Installation Instructions.

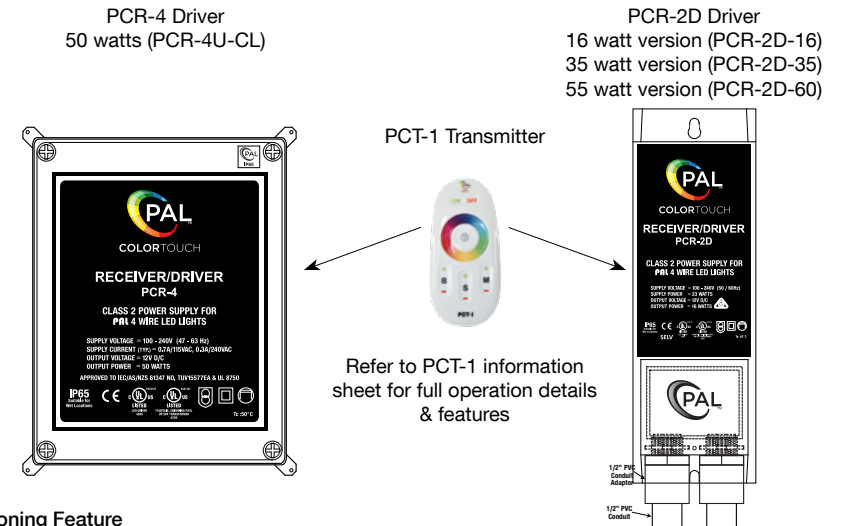

Cloning Feature

DIP 1	DIP 2	CLONING DIP SWITCH SETTING
OFF	ON	JANDY
OFF	OFF	PENTAIR
ON	OFF	HAYWARD
ON	ON	PAL

NOTE:

- Must turn off power before making DIP switch selection.
- When synching PAL lights to other OEM lights, static colors will match but color change mode timing may vary.
- If the PAL Lights are to be used with Automation, do not use the handheld remote control and disconnect the Wi-Fi module from the board if so equipped.
- If the Automation does not turn the PAL lights on or off and there is power to the driver, press the S1 button one time to turn on the PAL Driver.
- Note that the PAL features of infinite color selection and dimmability are not available while in Cloned mode.

TROUBLESHOOTING

Model: 4 Wire Evenglow Light

ISSUE	REASON	ACTION
Light not turning on (1)	Faulty Globe.	Replace Globe.
Light not turning on (2)	Faulty Driver.	Check Driver output under load using a multimeter. 12volts DC.
Light not turning on (3)	Cut Cable.	Check the voltage at light using a multimeter.
Light not turning on (4)	Driver not connected to GPO or switched on.	Check Driver is connected to power, check power indicator LED is lit on your Driver. If still no indicator light, send back to PAL for repair.
Light not turning on (5)	Faulty LED Driver inside control box.	Push the test button inside control box, if lights still doesn't turn on then send product back to PAL.
Lights out of sync (1)	Light incorrectly wired to control box.	Check color wire sequences connecting to control box.
Lights out of sync (2)	Lights incorrectly wired to LED lamp.	Check color sequences to LED lamp terminal block inside the light.

TERMS AND CONDITIONS

PAL PRODUCT WARRANTY DETAILS

The PAL product is guaranteed against defects in materials and/or workmanship, under normal domestic use for (36) thirty-six months.

Except as otherwise provided for by law, this guarantee becomes invalid if in the opinion of the Company the product has been misused, abused, damaged in transit, incorrectly installed, or connected to an electrical supply not corresponding with the products specification or a non-approved PAL power supply.

The Company is not responsible for forwarding freight charges or losses in transit.

If any part of the product proves to be defective within the warranty period, the defective part will be repaired or replaced, free of charge and at the discretion of Bellson Electric.

Bellson Electric shall not be liable for any loss of profits or any consequential, indirect or special loss, damage or injury of any kind whatsoever arising directly or indirectly from Bellson Electric products. This limitation does not apply to any liability under the Australian or New Zealand consumer legislation.

PLEASE REGISTER YOUR PRODUCT WARRANTY DETAILS ONLINE AT:

www.bellson.com.au/register.htm

OR You MUST retain some proof of purchase to provide evidence of the DATE of the original purchase.