

Treo LED Light

OWNER'S MANUAL

**ATTN: INSTALLER – THIS DOCUMENT IS TO BE LEFT
WITH POOL OWNER**



For lights equipped with FLED-LAU-C Color Changing or
FLED-LAU-W White Light only lamps.

This product is protected by one or more of the following U.S. Patents: 6781329, 6936978 and 6967448

**CORPORATE HEADQUARTERS
WESTERN SALES AND MANUFACTURING PLANT
P.O. Box 400 • 1017 SW Berg Parkway
Canby, Oregon 97013
Phone: (503) 266-2231 • Fax: (503) 266-4334
www.srsmith.com**



Intertek

4005496
CONFORMS TO UL STD 676
CERTIFIED TO CSA C22.2 #89

Basic Operation for LED Color Changing Lamp (RGB) - White Only

lamps are simply on or off

Advanced control requires iStar Controller - see operation manual for further instructions

When connected to an approved, 12VAC, Class 2 power supply - The S.R.Smith Treo LED color changing light uses simple 'off / on' power switching to control the basic, pre-defined color modes with memory function. This allows for a variety of simple control layouts to best fit your application.

Memory

The new memory function will allow the user to have the same color light as last used. For example, if the light was last used in Blue mode, the next time the light is simply turned on - it will use the memorized color.

Color Mode Selection

Due to the memory function, when the lights are switched on, they will display the last used color. To move to the next color mode, simply toggle the power to the lights 'OFF / ON' within 1 second or faster.

Advance through the modes until the desired color (mode) is selected - the modes will cycle 1,2,3,4,5,6,7,8, then cycle back to #1 and repeat (see table at bottom of this page).

Color Sync - Reset

The memory function may make it difficult get all lights to Color Sync depending on how the lights are installed and tested. To synchronize all lights on the system including older *Fiberstars LED Series Pool lights, you must use the following sequence:

1. Turn lights 'ON' to confirm the color modes are out of sync.
2. Turn lights 'OFF' for 5 seconds or more.
3. Toggles lights 'ON' / OFF' three times within three seconds - must end in 'OFF' condition
4. Leave lights in 'OFF' condition for 5 seconds.
5. Turn lights 'ON' and confirm that all lights are in mode #1, Soft Color Change

Color Mode Selection Guide	
Mode 1	Soft Color Change
Mode 2	White
Mode 3	Blue
Mode 4	Green
Mode 5	Red
Mode 6	Amber
Mode 7	Magenta
Mode 8	Flash Color Change

* Older Fiberstars LED lights can synchronize with the newest generation lights ONLY if they have their DIP switches in their default, 'All Down' position. In a mixed environment, the Color Sync Reset will need to be performed each time the lights are used and color synchronization is desired.

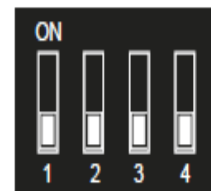

The 3 year, non-transferable, factory warranty starts from date of purchase.

S.R.Smith Treo Winterization Recommendations

Swimming Pools may or may not be drained completely. If not drained completely, the water level should be lowered below the S.R.Smith Treo LED Light and make sure that all water is drained from the wall fitting and conduit. Alternatively, the Treo LED Light may be removed completely, the conduit purged of all water, and a 1 1/2" NPT male plug w/ thread sealing tape may be used to close the wall fitting.

NOTE - If water is trapped in conduit, damage may occur from freeze expansion.

Lamp Replacement Instructions for S.R.Smith Treo Light

1. Depending on your particular installation, lowering the water level may or may not be required. Extra cord may have been coiled inside the conduit or near the power equipment. Only open the light body in a 'dry' environment, above the water level.
2. Unscrew the Color Bezel Ring from the light body.
3. Unscrew the (6) six lens screws to unclip the lamp from the lamp socket as shown on the Assembly drawing below.
4. Replace the FLED-LAU (C or W) Lamp. Note: To ensure reliable operation of your S.R.Smith Treo, it is essential to use a genuine S.R.Smith LED lamp. Lamp/Seal Replacement kit part no. **FLED-LAU-C or FLED-LAU-W**. When the Lamp is replaced it is important to maintain the water tight seal so the "O" ring should also be replaced, a new "O" ring seal is always supplied with the Lamp / Seal replacement kit. (FLED-LAU-C or FLED-LAU-W).
5. When reassembling the S.R.Smith Treo, ensure the "O" ring is sitting correctly and that the lamp keyway notches fit the housing tabs. Replace the (6) lens screws and ensure the screws are snug but not over tightened. Screw on the colored Bezel Ring to the light housing.
6. Feed wire back into the wall fitting / conduit if light was removed from the wall.

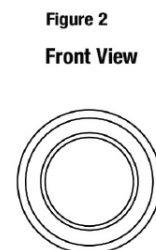
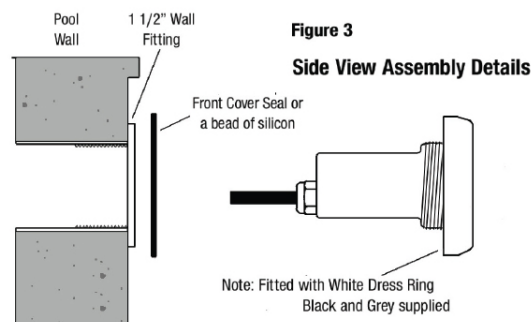
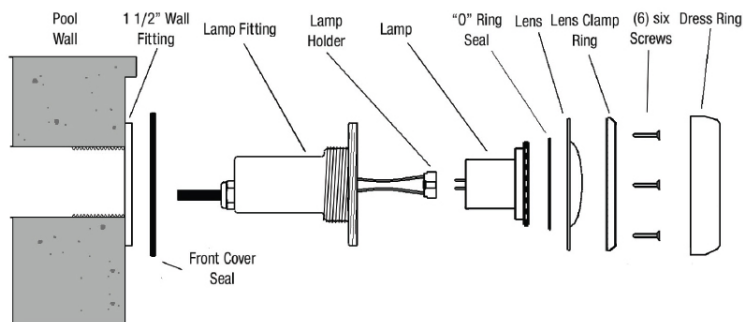

This light is equipped with a thermal protection circuit built into the LED lamp assembly. If the circuit detects that the lamp assembly is getting too hot for a given environment, it will automatically reduce the brightness in increments until the lamp remains below the thermal threshold. If this condition occurs, it may or may not be noticeable by the human eye and is a normal function, not a sign of malfunction or failure.