



**SUPERVISION**  
INTERNATIONAL

**SaVi**<sup>TM</sup>  
architectural LED lighting

## INSTALLATION INSTRUCTIONS & OWNERS MANUAL

### NOTE TO INSTALLER



**GIVE THIS MANUAL  
TO THE OWNER/  
OPERATOR AFTER  
INSTALLATION.**

This manual is for the following models:

SaVi-PL-12-50

SaVi-SL-12-50

SaVi-PL-12-100

SaVi-SL-12-100

SaVi-PL-120-50

SaVi-SL-120-50

SaVi-PL-120-100

SaVi-SL-120-100



Pictured: SaVi-PL-120 - SaVi Pool Light (120V) with beauty plate.

### RISK OF ELECTRICAL SHOCK OR INJURY



This underwater light must be installed by a licensed or certified electrician in accordance with the National Electrical Code and applicable local codes and ordinances. Improper installation will create an electrical hazard, which could result in death or serious injury to pool or spa users, installers, or others due to electrical shock, and may also cause damage to property. Read and follow the specific instructions below.



**PRODUCT INFORMATION**



SaVi Spa Light with beauty plate removed.



SaVi Pool Light with beauty plate removed.

**SaVi SPA LIGHT  
MODEL NUMBERS**

- SaVi-SL-12-50
- SaVi-SL-12-100
- SaVi-SL-120-50
- SaVi-SL-120-100

**SaVi POOL LIGHT  
MODEL NUMBERS**

- SaVi-PL-12-50
- SaVi-PL-12-100
- SaVi-PL-120-50
- SaVi-PL-120-100

**All Units Fit The Following SPA NICHES:**

**Hayward Spa Niche**

- SP0601U - concrete pools

**Pentair Spa Niche**

- 79206600 - concrete pools

**All Units Will Fit The Following POOL NICHES - Only When Used With Super Vision RETROFIT PLATE Part #: SaVi-Plate-W or SaVi-Plate-B**

**Hayward Pool Niches**

- SP0600U - concrete pools
- SP0607U - concrete pools

**Pentair Pool Niches**

- 79206700 - concrete pools
- 62004 - vinyl liner pool

**WARNING - NEVER ATTEMPT TO OPEN THIS LIGHT FIXTURE!**



NEVER ATTEMPT TO OPEN THE LIGHT FIXTURE – THERE ARE NO SERVICEABLE PARTS IN THE FIXTURE AND ANY ATTEMPTS TO OPEN THE FIXTURE MAY RESULT IN PERMANENT AND IRREPARABLE DAMAGE AND MAY CAUSE A SAFETY HAZARD IF RE-INSTALLED IN A POOL OR SPA.

# PRODUCT INFORMATION

SaVi™



**SUPER VISION**  
INTERNATIONAL

## DETAILED PRODUCT DESCRIPTION

Product	Description	Cord Length (ft)	Minimum Voltage Required (VAC)	Wattage Draw Nominal/Max (W)	Recommended Transformer	
N/A	Pool Light	20 feet	12 Volt AC	90/110 Watts	12V / 150W	PX-300
SaVi-PL-12-50	Pool Light	50 feet	13 Volt AC	90/110 Watts	13V / 150W	PX-300
SaVi-PL-12-100	Pool Light	100 feet	14 Volt AC	90/110 Watts	14V / 150W	PX-300
N/A	Pool Light	20 feet	120 Volt AC	120/145 Watts	N/A	N/A
SaVi-PL-120-50	Pool Light	50 feet	120 Volt AC	120/145 Watts	N/A	N/A
SaVi-PL-120-100	Pool Light	100 feet	120 Volt AC	120/145 Watts	N/A	N/A
N/A	Spa Light	20 feet	12 Volt AC	24/28 Watts	12V / 100W	PX-100
SaVi-SL-12-50	Spa Light	50 feet	13 Volt AC	24/28 Watts	13V / 100W	PX-100
SaVi-SL-12-100	Spa Light	100 feet	13 Volt AC	24/28 Watts	13V / 100W	PX-100
N/A	Spa Light	20 feet	120 Volt AC	34/40 Watts	N/A	N/A
SaVi-SL-120-50	Spa Light	50 feet	120 Volt AC	34/40 Watts	N/A	N/A
SaVi-SL-120-100	Spa Light	100 feet	120 Volt AC	34/40 Watts	N/A </tr	

\* Note: Max Watt Draw is on white light only. Other colors will draw less current.

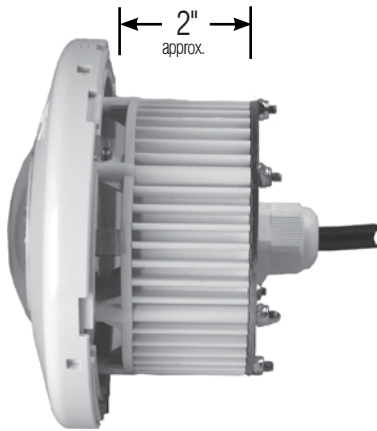

12 Volt **POOL** Fixture  
12 Volt **SPA** Fixture

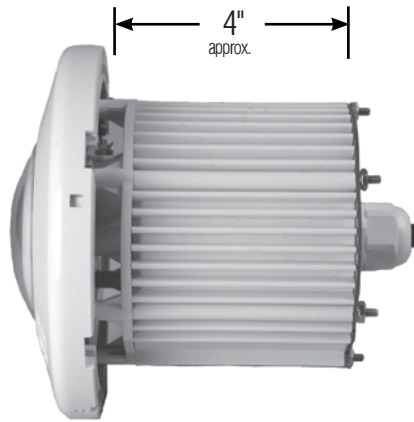

120 Volt **POOL** Fixture  
120 Volt **SPA** Fixture



SaVi **POOL** Fixture  
with Beauty Plate





SaVi **SPA** Fixture  
with Beauty Plate

## GENERAL INFORMATION - SAVE THESE INSTRUCTIONS

The underwater lighting fixture you have purchased is ETL Listed under file number 3089958CHI and must be used with an appropriate ETL or UL Listed fixture housing (niche). Installation of light and niche must be in accordance with Article 680 of the National Electrical Code (NEC) and any applicable local codes. If non-metallic conduit is used a # 8 AWG grounding conductor must be run through conduit and connected to grounding connector on inside of niche. This connection must be encapsulated using a listed potting compound in accordance with NEC Article 680.23B2 (3M Inc. Scotch Cast Wet Niche Potting Compound No. 2135 (UL File E130394 or equivalent)). The integral external connection is for the # 8 AWG bonding conductor also required by the NEC.

This fixture is equipped with an Automatic Shutdown Mode to protect the light fixture if it is operated while not submerged in water. If operating temperatures exceed the normal design temperatures expected with standard submerged installations, the light will enter the "Shutdown Mode" where the light will power down to a lower setting and glow red. Once the light has cooled down it will resume normal operation. If the light does not resume normal operation try resetting the light (turn the light off for 3-5 seconds before turning back on) to see if the over-heated condition has cleared.

### RISK OF ELECTRICAL SHOCK OR INJURY

	<p>This underwater light must be installed by a licensed or certified electrician in accordance with the National Electrical Code and applicable local codes and ordinances. Improper installation will create an electrical hazard, which could result in death or serious injury to pool or spa users, installers, or others due to electrical shock, and may also cause damage to property. Read and follow the specific instructions below.</p>
	

### IMPORTANT SAFETY INSTRUCTIONS

	<p>When installing and using this electrical equipment, basic safety precautions should always be followed, including the following: Failure to follow instructions may result in injury.</p>
---	---

### READ AND FOLLOW ALL INSTRUCTIONS

1. Warning - To reduce risk of injury, do not permit children to use this product unless they are closely supervised at all times.
2. Caution - This swimming pool / spa light is ETL Listed for permanently installed pools or spas. It is not listed for storable pools or spas. Permanently installed pools are those constructed in or partially in the ground and all others capable of holding water in a depth greater than 42 in (1.07m). Storable pools are those constructed on or above the ground and capable of holding water to a maximum depth of 42 in. (1.07 m).
3. This Light Fixture must be installed by qualified personnel in compliance with the National Electrical Code (NEC) and any applicable local codes.
4. Disconnect Electrical Power before installation.
5. Improper installation may result in death or serious injury to bathers or service personnel or others by way of electrical shock. Read and follow the instructions below

**CAUTION:** We highly recommend having a qualified professional install the product. Be sure power supply has been shut off or disconnected. Failure to do so could result in severe personal injury.

## INSTALLATION INSTRUCTIONS

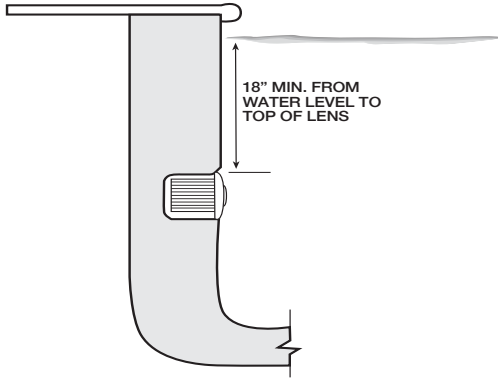

Diagram for Step 1

### STEP 1

The light fixture must be installed in or on a wall of the pool with the top of the lens opening not less than 18 inches (15.24cm) below the normal water level of the pool except when the fixture is installed in an area of the swimming pool that is not used for swimming and the lens is adequately guarded to prevent any person from contacting it.

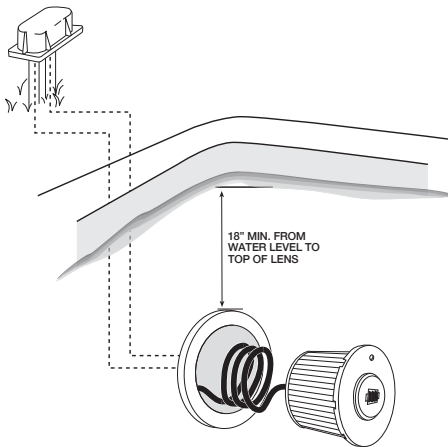

Diagram for Step 2

### STEP 2

Snake the 3-conductor electric cord and a #8 AWG ground wire (when non-metallic conduit is used) through the conduit outlet of the fixture housing (niche), into the conduit and up to the junction box. **DO NOT CUT EXCESS CORD.** Leave adequate cord in niche (Do NOT wrap cord around fixture) so that fixture will be able to be raised to deck if required. Cut off extra cord after, allowing for service and length of run to box.

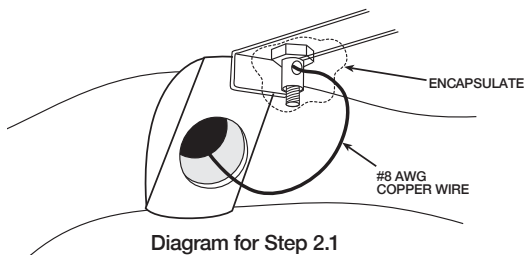

Diagram for Step 2.1

### STEP 2.1

If non-metallic conduit is used, connect the #8 AWG ground wire through conduit to connector on inside of fixture housing (niche). This termination must be encapsulated using a listed potting compound\* to a thickness of at least 1/8 inch in accordance with article 680 of the NEC.

\* 3M Inc. Scotch Cast Wet Niche Potting Compound No. 2135 (UL File E130394) or equivalent.

**INSTALLATION INSTRUCTIONS (cont.)**

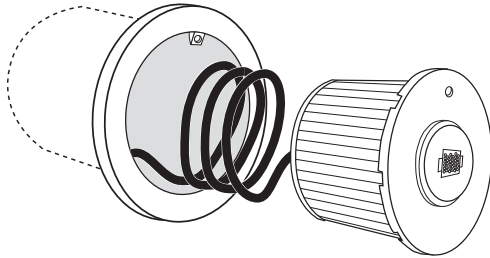

Diagram for Step 3

**STEP 3**

Coil the extra electric cord into the niche so it fits behind the lighting fixture (see diagram). Place the fixture into the niche with face rim lock-screw at top (12 o'clock). Snap the spring clip at the bottom of the face rim onto the notch in the bracket at the lower edge of the niche. Be sure it catches. Secure the fixture by threading the lock-screw into the mounting bracket at the top of the niche. Unthread lock-screw to remove fixture from niche.

**STEP 3.1**

Check the bushing space for the appropriate niche manufacturer.

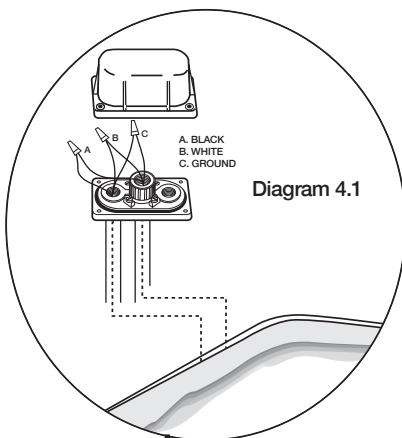
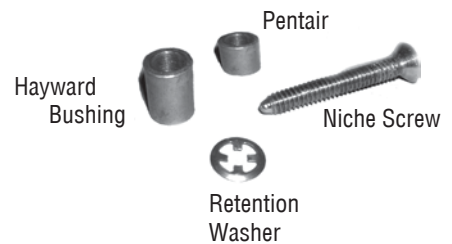

Diagram 4.1

**STEP 4**

Connect the light fixture cordset to the power supply within a listed junction box for swimming pool lighting fixtures (See Diagram 4.1). NOTE: Only a licensed electrician should perform wiring, splicing and grounding within the junction box.

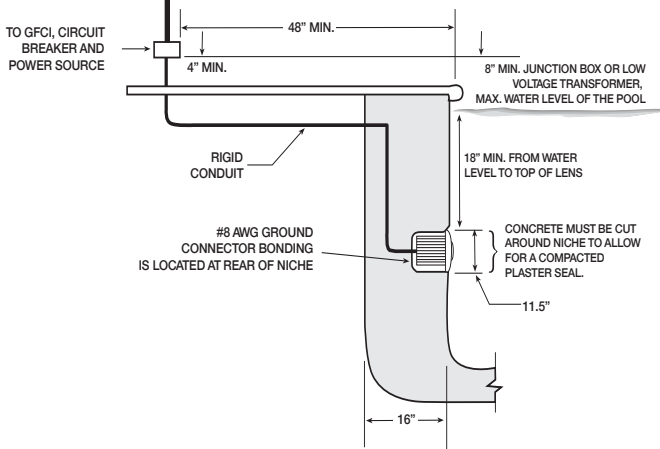

Diagram 4.2

Select a suitable location for the junction box not less than 48 inches (1.22 m) from the edge of the pool or spa. Run conduit from the niche up to the junction box such that the junction box is not less than 8 inches (20 cm) above the maximum pool or spa water level, or not less than 4 inches (10 cm) above the ground, whichever is greater. (See Diagram 4.2) Additional conduit should be run from the junction box to the power supply, switch panel, pool/spa controller, etc.

**NOTE:** See the next page (pg. 7) for diagrams on wiring 12V and 120V SaVi Pool and Spa Lights to Jandy Controllers and for wiring SaVi Pool and Spa Lights to a Time Clock.

## ADDITIONAL WIRING DIAGRAMS

12 Volt Pool & Spa Light Wiring Diagram for Jandy Controller

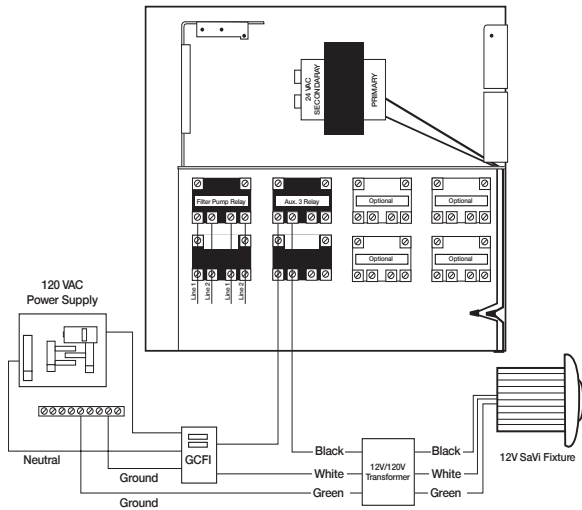

120 Volt Pool & Spa Light Wiring Diagram for Jandy Controller

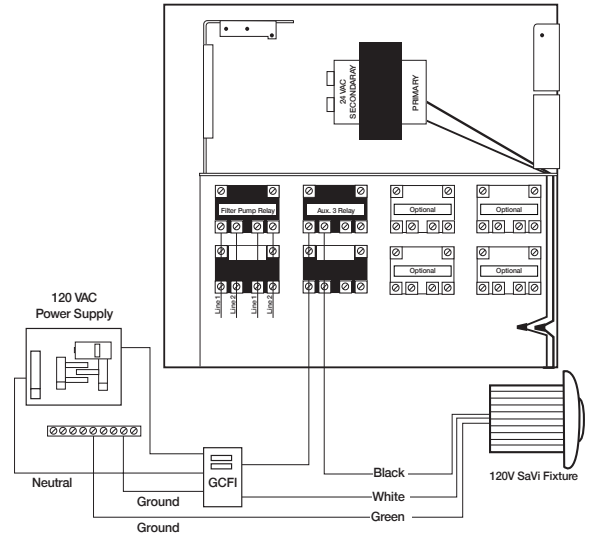

Wiring the SaVi Pool & Spa Light to a Time Clock

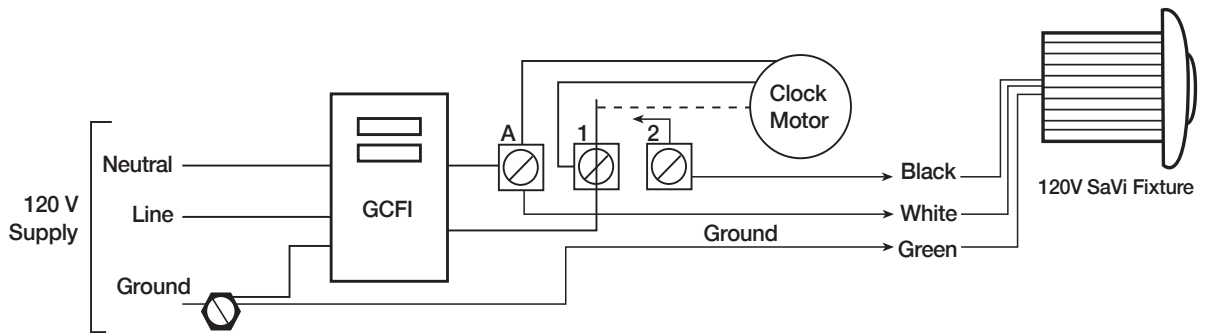

**OPERATING INSTRUCTIONS -Changing the color modes of the light.**

**PROGRAM GUIDE**

1. Treasure Island	smooth color transition
2. Moonlight White	fixed color
3. SaVi Blue	fixed color - dark blue
4. Sargassion Sea	fixed color - green
5. Blue Lagoon	fixed color - light blue
6. Passion Pink	fixed color
7. Caribbean Hues	blue - green fades
8. Copacabana	medium fast color changes
9. Dance Party	fast color changes

**I. OPERATING INSTRUCTIONS FOR POOL LIGHTS ONLY**

(SaVi-PL-12/120 - for pools without a spa)

**NOTE:** Your SaVi Pool & Spa Light will always come **ON** as white light for 13 seconds before initiating the “memory feature.” **DO NOT ATTEMPT TO CHANGE MODES DURING THIS TIME.**

How to **ADVANCE** the light(s) to the next color mode:

1. With the light(s) turned **ON**, turn the light switch to the **OFF** position.
2. Hold the light switch at the **OFF** position for 1-2 seconds and then turn the light switch back **ON**.
3. This will advance the light(s) to the next color mode. You may continue steps 1-2 in order to cycle through all the color options.

**NOTE:** If the light is **OFF** for 3-5 seconds and turned back **ON**, it will **NOT** change color modes. This is a design feature for SaVi Pool Lights combined with SaVi Spa Lights, so the lights can be unsynchronized.

<b>Pool Light Only (SaVi-PL-12/120)</b>	
<b>Time held at OFF position</b>	<b>Result</b>
1-2 seconds	<b>ADVANCE</b> light one color mode.
3-5 seconds	<b>NO</b> change (This is a design feature for Pools with SaVi Spa Lights).
6-9 seconds	<b>RESET</b> light(s) to first color mode (Treasure Island).
10 seconds or more	<b>“MEMORY FEATURE”</b> (remembers last color used).

How to **RESET** the light to the first color mode (Treasure Island):

1. With the light(s) turned **ON**, turn the light to the **OFF** position.
2. Hold the light switch at the **OFF** position for 6-9 seconds and then turn the light back **ON**.
3. The light(s) will flash green, blue & red before initiating first color mode (Treasure Island).

**MEMORY FEATURE:**

If the light is **OFF** for 10 seconds or more and turned back **ON**, it will return to the last color mode used.

**NOTE:** The light will always come **ON** as white light for 13 seconds for safety purposes before initiating the “memory feature”. **DO NOT ATTEMPT TO CHANGE MODES DURING THIS TIME.**





## OPERATING INSTRUCTIONS (cont.)

### II. OPERATING INSTRUCTIONS FOR SPA LIGHTS ONLY

(SaVi-SL-12/120 - for spas without a pool)

**NOTE:** Your SaVi Pool & Spa Light will always come **ON** as white light for 13 seconds before initiating the “memory feature.” **DO NOT ATTEMPT TO CHANGE MODES DURING THIS TIME.**

**How to ADVANCE the light to the next color mode:**

1. With the light(s) turned **ON**, turn the switch to the **OFF** position.
2. Hold the light switch at the **OFF** position for 1-5 seconds and then turn the switch back **ON**.
3. This will advance the light(s) to the next color mode. You may continue steps 1-2 in order to cycle through all the color options.

**How to RESET the light to the first color mode (Treasure Island):**

1. With the light(s) turned **ON**, turn the light to the **OFF** position.
2. Hold the light switch at the **OFF** position for 6-9 seconds and then turn the light back **ON**.
3. The light(s) will flash green, blue & red before initiating first color mode (Treasure Island).

**MEMORY FEATURE:**

If the light is **OFF** for 10 seconds or more and turned back **ON**, it will return to the last color mode used.

**NOTE:** The light will always come on as white light for 13 seconds for safety purposes before initiating the “memory feature”. **DO NOT ATTEMPT TO CHANGE MODES DURING THIS TIME.**

Spa Light Only (SaVi-SL-12/120)	
Time held at OFF position	Result
1-5 seconds	ADVANCE light one color mode.
6-9 seconds	RESET light(s) to first color mode (Treasure Island).
10 seconds or more	“MEMORY FEATURE” (remembers last color used).

### III. OPERATING INSTRUCTIONS FOR POOL & SPA LIGHT COMBINATIONS

(SaVi-PL-12/120 & SaVi-SL-12/120)

**NOTE:** Your SaVi Pool & Spa Lights will always come **ON** as white light for 13 seconds before initiating the “memory feature.” **DO NOT ATTEMPT TO CHANGE MODES DURING THIS TIME.**

**How to ADVANCE both lights to the next color mode:**

1. With the light(s) turned **ON**, turn the light switch to the **OFF** position.
2. Hold the light switch at the **OFF** position for 1-2 seconds and then turn the switch back **ON**.
3. This will **ADVANCE** both lights to the next color mode. You may continue steps 1-2 in order to cycle both lights through all the color options together.

Pool & Spa Light Combination (SaVi-PL-12/120 & SaVi-SL-12/120)	
Time held at OFF position	Result
1-2 seconds	ADVANCE <b>all</b> Lights one color mode.
3-5 seconds	ADVANCE Spa Light, FREEZE Pool Light.
6-9 seconds	RESET lights to first color mode (Treasure Island).
10 seconds or more	“MEMORY FEATURE” (remembers last color used).

## OPERATING INSTRUCTIONS (cont.)

### How to ADVANCE only the Spa Light(s) one mode and FREEZE the Pool Light(s):

1. With the light(s) turned **ON**, turn the light switch to the **OFF** position.
2. Hold the light switch at the **off** position for 3-5 seconds and then turn the switch back **ON**.
3. This will **ADVANCE** the Spa Light(s) to the next color mode while keeping the Pool Light **FROZEN**.

Here are two approaches to get multiple color and color mode combinations:

1. Continue to use the 3-5 second approach after the Pool and Spa lights are “out of sync” – in other words: keep the pool light(s) **FROZEN** and continue to **ADVANCE** the spa light(s) to an interesting color mode of your liking.

OR

2. Once the pool and spa lights are “out of sync” use the 1-2 second lapse to **ADVANCE** both the pool and Spa lights together one position at a time.

### How to RESET the lights to the first color mode (Treasure Island):

1. With the light(s) turned **ON**, turn the light switch to the **OFF** position.
2. Hold the light switch at the **OFF** position for 6-9 seconds and then turn the light switch back **ON**.
3. The light(s) will flash green, blue & red before initiating first color mode (Treasure Island).

### MEMORY FEATURE:

If the light is **OFF** for 10 seconds or more and turned back **ON**, it will return to the last color mode used. **NOTE:** The light will always come **ON** as white light for 13 seconds for safety purposes before initiating the “memory feature”. **DO NOT ATTEMPT TO CHANGE MODES DURING THIS TIME.**

## FAQ / TROUBLESHOOTING:

1. The light is white for around 13 seconds then goes to the last color used. This is a safety feature built into the “Memory Feature.” Nothing is wrong with the light. **NOTE: YOU CANNOT CHANGE MODES DURING THE FIRST 13 SECONDS OF TURNING ON THE LIGHT.**
2. Nothing happens when I turn the switch off and back on to change color modes on my SaVi Pool Light (applies to pool lights ONLY, SaVi-PL-12/120). Try shortening the amount of time you have the switch in the off position. If you have the switch off for 3-5 seconds, no change will occur. You must have the switch off for no more than 2 seconds to change color modes for the SaVi Pool Light. Refer to the operating instructions for the time delay (in seconds) that the light switch should be off.
3. My light is glowing a reddish color. This fixture is equipped with an Automatic Shutdown Mode to protect the light fixture if it is operated while not submerged in water. If operating temperatures exceed the normal design temperatures expected with standard submerged installations, the light will enter the “Shutdown Mode” where the light will power down to a lower setting and glow red. Once the light has cooled down it will resume normal operation. If the light does not resume normal operation try resetting the light (turn the light off for 6-9 seconds before turning back on) to see if the over-heated condition has cleared. If this does not resolve the problem contact a service professional.
4. My light is not working. Check the circuit breaker and /or GFI circuit breaker. You may also keep the light off overnight to allow all electrical charges to dissipate before turning it back on. If the light continues to not function correctly, contact a service professional.

## WARNING



NEVER ATTEMPT TO OPEN THE LIGHT FIXTURE – THERE ARE NO SERVICEABLE PARTS IN THE FIXTURE AND ANY ATTEMPTS TO OPEN THE FIXTURE MAY RESULT IN PERMANENT /IRREPARABLE DAMAGE AND MAY CAUSE A SAFETY HAZARD IF RE-INSTALLED IN A POOL OR SPA.

# ACCESSORIES

SaVi™



SUPERVISION  
INTERNATIONAL

## SaVi POOL & SPA ACCESSORIES

Below are some accessories you can purchase for you SaVi Pool & Spa Light.



Part Number: SaVi-FNT-KIT



Shown with SaVi Pool Light attached.

**SaVi Pool or Spa Light Fountain Bracket**

**Adaptor for Pool Niche**



Part Numbers: SaVi-Plate-W (above)  
SaVi-Plate-B (black) not shown



Shown with SaVi Pool Light inserted.

**Beauty Plate Accessory/Replacement for SaVi Pool or Spa Light**

**NOTE: Your SaVi Pool & Spa Light comes with the default White Beauty Plate.**



**Black Beauty Plate**  
Part Number: SaVi-BP-B

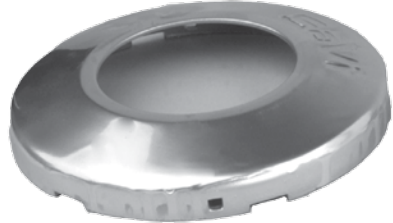

**Chrome Beauty Plate**  
Part Number: SaVi-BP-C



**White Beauty Plate**  
Part Number: SaVi-BP-W

## WARRANTY INFORMATION

### **LIMITED WARRANTY**

Super Vision International, Inc. warrants its products, excluding lamps, to be free from defects in material and/or workmanship, under normal condition, use and service, for a period of two (2) years from the original invoice date (Five (5) Years for Red, Amber and Orange FlexLED and Border Light LED products and one (1) Year for Non-UL Listed Power Supplies). If proof of purchase is provided, Super Vision will warranty the product for two (2) years from date of the purchase (Five (5) Years for Red, Amber and Orange FlexLED and Border Light products and one (1) Year for Non-UL Listed Power Supplies).

### **TERMS AND CONDITIONS:**

This warranty only applies when Super Vision products are properly wired and installed together as a system; and operated within the electrical values shown on the Super Vision specification sheets; used in lighting equipment designed and approved for the application and environmental conditions (temperature, humidity) within the normal specified operating range of the system. This warranty does not apply to any abnormal use in violation of any applicable standard, code or instructions for use in installations including those contained in the latest National Electrical Code (NEC), the Standards for Safety of Underwriters Laboratory, Inc. (UL), Standards for the American National Standards Institute (ANSI), in Canada, the Canadian Standards Association (CSA), Europe (CE), Australia (C-Tick). This warranty will not apply in the event of conditions demonstrating abnormal use or stress, including under/over voltage conditions, excessive switching cycles, excessive operating hours, alterations, accident, theft, misuse, abuse and damaged caused by negligent installation, improper maintenance or where adequate care has not been taken to prevent damage to the lighting system. Replacement of Super Vision components with any other manufacturer will void the entire warranty.

### **WARRANTY SERVICE CLAIMS:**

Super Vision must issue a Return Material Authorization (RMA) number for all requests for warranty review. To expedite service, please contact Super Vision Customer Representative: 1-407-857-9900. If you are unsure whether a situation exists that is covered by this warranty, please contact Super Vision Customer Service for assistance. In the event of a defect in material or workmanship during the warranty period, Super Vision will repair or replace (at its own discretion) its products under the conditions of the warranty.

### **RETURN OF DEFECTIVE PRODUCT:**

After contacting Super Vision and receiving the RMA#, the purchaser / user shall promptly return the product after receiving instructions regarding if, when and where to ship product. Product must be returned within 30 days of receiving RMA#, Shipping box must be clearly marked with RMA#. Failure to follow this procedure shall void this warranty. Super Vision will cover expenses for material but will not cover shipping costs. Products returned without an RMA# will be refused and returned to sender at the senders expense.

### **REPLACEMENT OF PRODUCT, LIMITS OF LIABILITY:**

The foregoing shall constitute the exclusive remedy of the purchaser and the sole liability of Super Vision International regarding its products and component warranty. **NO WARRANTY OF MERCHANTABILITY OR FITNESS FOR A PARTICULAR PURPOSE IS MADE OR IS TO BE IMPLIED.** In no event shall Super Vision be liable for any other costs or damages including labor charges, lost profits or revenues, incidental, special or consequential damages. Total liability shall not exceed the total extended purchase price for the product. Super Vision reserves the right to examine all failed Super Vision products and components to determine the cause of failure and patterns of usage and reserves the right to be the sole judge as to whether any product or component is defective and covered under this warranty.

March 30, 2005 Rev. 0

INS.PSL.0406.V01.03