

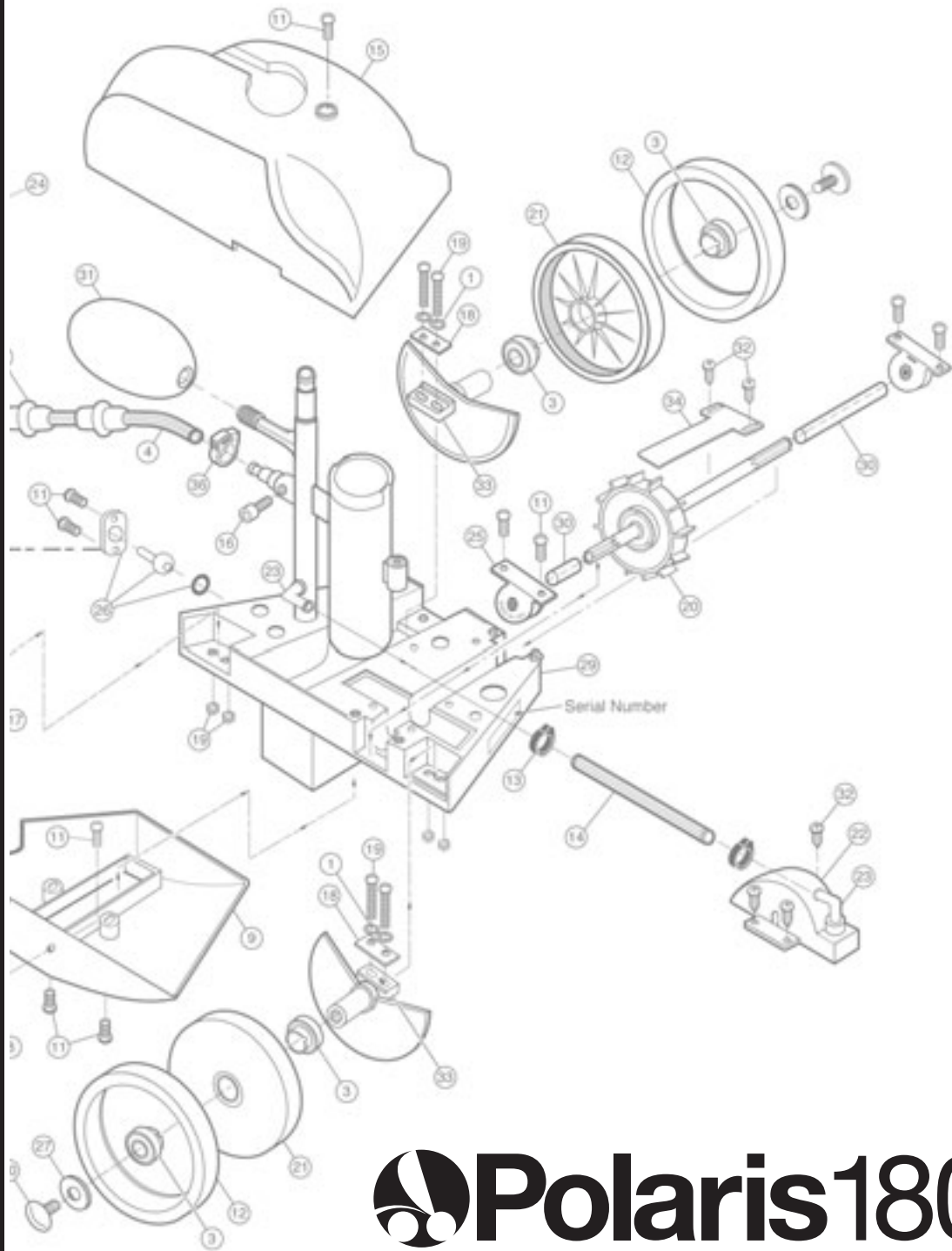

# FACTORY TUNE-UP KIT



 **Polaris180**  
 **Polaris280**

INSTALLATION INSTRUCTIONS

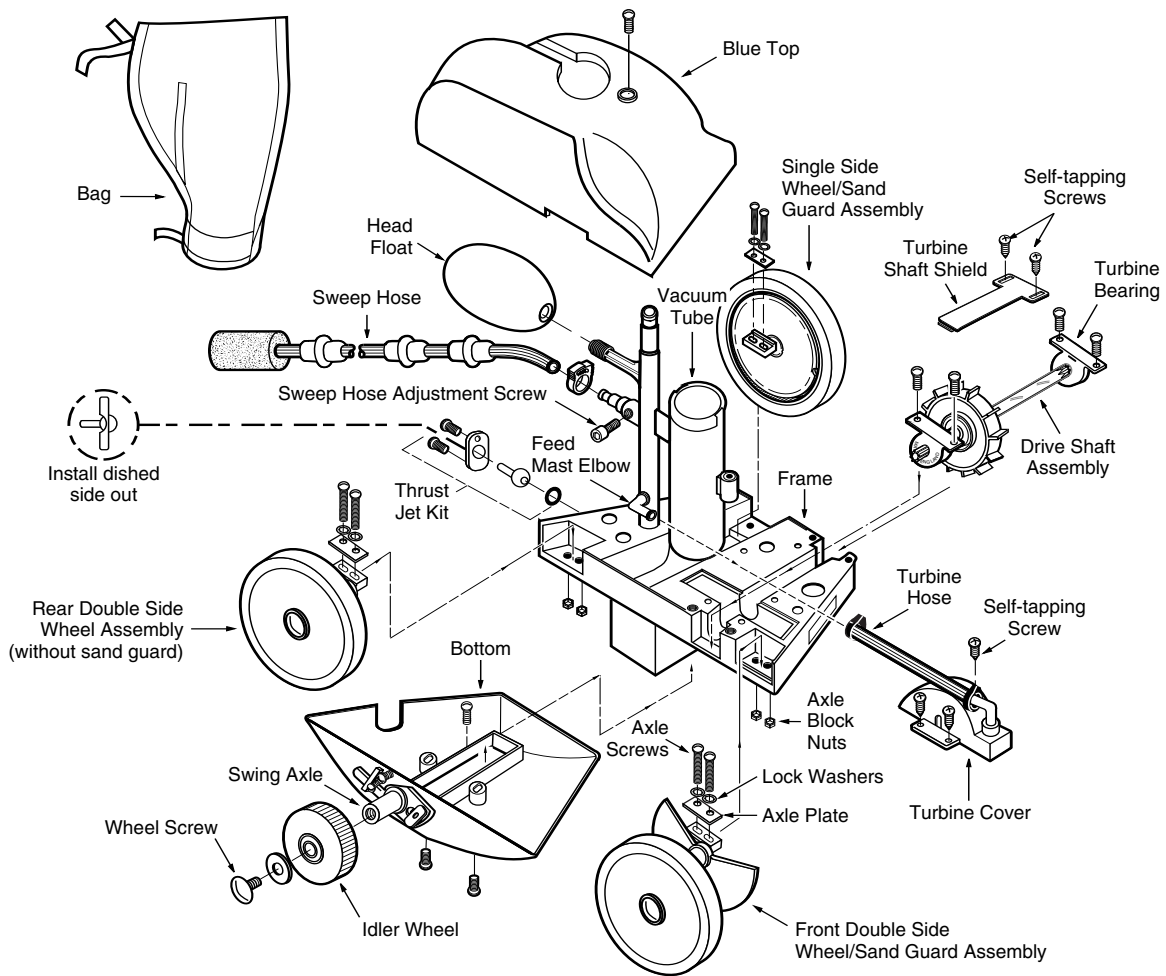

**If you have any additional questions, please contact our Customer Service Department toll-free at 1-800-822-7933.**

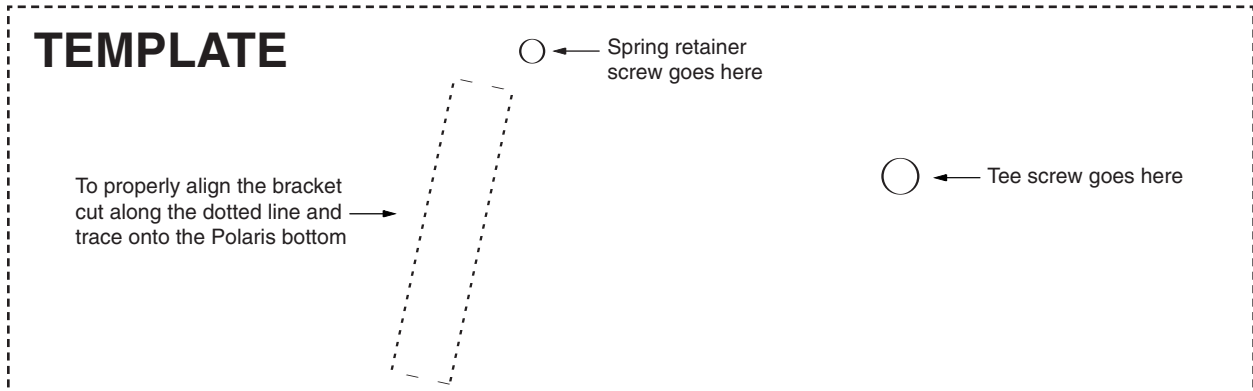

## Tools Needed:

Philips screwdriver

Needle nose pliers

Small flathead screwdriver

ABS glue

## Disassembly

1. Mark the position of the head float on the feed mast. Remove the head float.
2. Remove the bag. Mark the position of the sweep hose adjustment screw and remove. Remove the sweep hose attach clamp and sweep hose.
3. Remove the top.
4. Label the single-side wheel and the front double-side wheel so that once removed you can tell them apart. Remove the axle screws and the wheel assemblies for the three large wheels. Set the screws(6), axle plates(3) and lock washers(6) aside for reassembly.
5. Remove the three turbine cover screws and move turbine cover over (hose and cover attached to feed mast) to expose turbine/drive shaft.
6. Remove the two turbine bearings and turbine/drive shaft and discard. Retain the screws(4). Remove the shaft shield. Retain the shield and screws(2).
7. Remove the bottom of the cleaner. Retain the screws(2).
8. Remove and retain the six loose axle block nuts. If they are not in the bottom, they are still in place in the frame.
9. Remove the idler wheel, washer and plastic screw from the bottom and discard.
10. Remove the swing axle tee screw, the spring retainer screw and swing axle. **180 only:** If the retaining bracket is worn or broken, remove any remaining portion from the bottom.

## Assembly

**Please note: Do not over tighten the screws, they only need to be installed hand-tight.**

1. Place the new turbine bearings and drive shaft assembly into position and replace the four screws. **Please note: Do not remove the clear tubes on the drive shaft, they are designed to ensure proper turbine spacing.**

2. Reinstall the turbine cover using three of the screws.
3. Using two screws, reinstall the turbine shield. Note: The lip on the turbine shield goes under the turbine cover.
4. Lay the old front double-side wheel next to a new wheel/sand guard assembly. Point the axle on each wheel in the same direction (see drawing). Use needle-nose pliers to remove a notch from the new wheel in the same place as the old wheel. Repeat for single-wheel side. Discard old wheel assemblies.

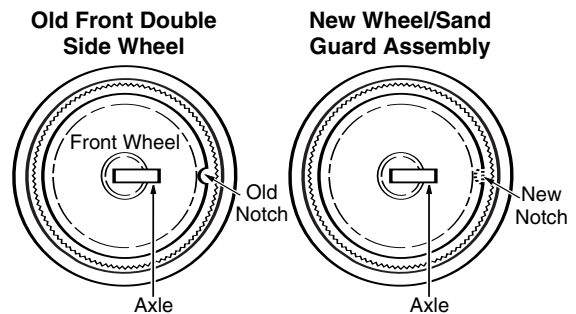

5. Install the new front double-side wheel with the axle plate and the new lock washers. Make sure the grooves in the axle line up with the ribs on the frame. Leave the screws loose enough to adjust the wheel position.
6. Adjust the wheel so the spline of the drive shaft assembly engages 3/4 of the wheel gear teeth (see drawing). It is easier to see the engagement if you peel back the tire. To test the wheel placement, spin the wheel; it should spin and turn the drive shaft. Also, hold the wheel and quickly rotate it back and forth. The gears should not slip or chatter.

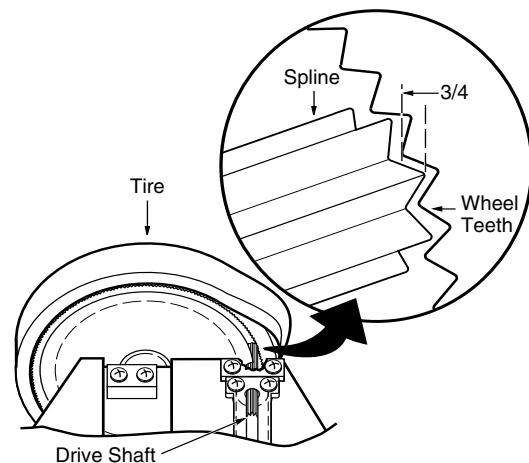

7. Repeat steps 5-7 for the single-side wheel.
8. Align the threads on the frame and install the rear wheel assembly (this wheel does not have a sand guard) using the axle plate and lock washers. The longest part of the wheel axle should point toward the rear of the cleaner. Leave the screws loose enough to adjust the wheel position.
9. **180 only:** Use the template provided to properly align the new swing axle retaining bracket. Cut out the slot indicated and align the spring retainer screw hole and the swing axle tee screw hole with the holes in the Polaris bottom. Trace the area that you cut out onto the Polaris bottom and remove the template. Using ABS glue, install the new bracket onto the Polaris bottom within the traced area. Allow approximately 12 hours for the glue to dry.
10. Install the swing axle, swing axle tee, lock washer and spring. Ensure that the tee is parallel with the retaining bracket.
11. Install the new idler wheel onto the swing axle on the bottom. Use the new wheel washer and plastic wheel screw. Do not overtighten the screw; the wheel should spin freely.
12. Install the bottom onto the frame.
13. Slide the rear wheel forward until it just contacts the idler wheel and tighten the axle block screws. When you spin the rear wheel, it should slip slightly against the idler wheel. When you spin the front wheel, all the wheels should spin together.
14. Reinstall the top. Do not overtighten the screw.
15. Screw the sweep hose adjustment screw into place, positioning at the mark made earlier. Attach the sweep hose with the attach clamp.
16. Position the head float to the mark on the feed mast.
17. Reattach the all-purpose bag.

