

SandPRO™ POOL FILTER SYSTEM OWNER'S MANUAL

MODELS 4517

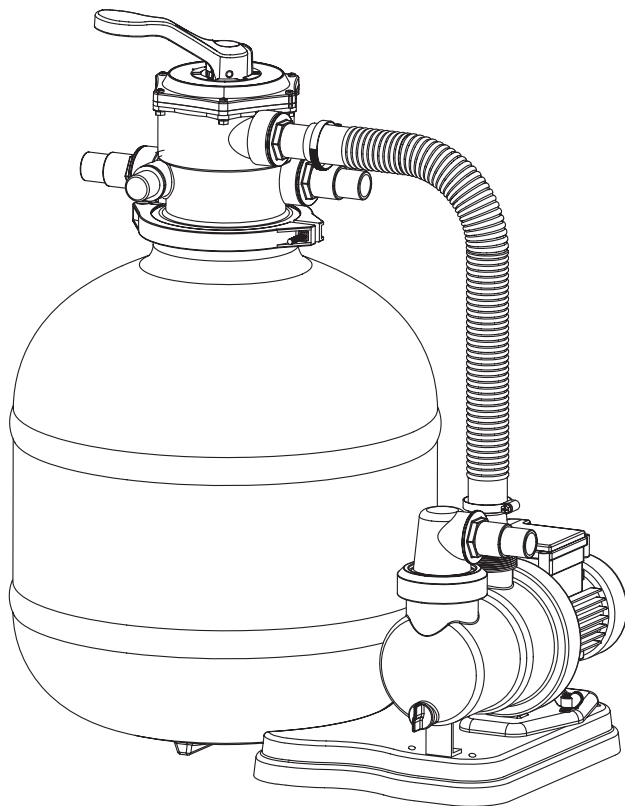

Sand not included. USE ONLY No. 20 Silica Sand with a particle size of 0.45 mm – 0.55 mm

IMPORTANT
DO NOT RETURN PRODUCT TO STORE

For technical assistance and missing parts, call Customer Service toll-free

1.888.339.2546

(press 135 at any time)

Monday through Friday, 8 am to 5:00 pm MST

Saturday, 8:00 am to 1:00 pm MST



Your Pool Filter System has been engineered and manufactured to our highest standard for dependability, ease of operation and safety. With proper care, it will give you years of durable, trouble-free performance.
Thank you for your purchase.

**PRIOR TO ASSEMBLING AND USING THIS PRODUCT,
CAREFULLY READ AND ADHERE TO ALL CAUTION AND IMPORTANT
NOTICES LOCATED THROUGHOUT THIS MANUAL.
FAILURE TO COMPLY WITH THESE INSTRUCTIONS MAY DAMAGE
TO THE PRODUCT OR CAUSE SERIOUS PERSONAL INJURY OR DEATH.**

In this manual, some of the following callouts may be used. Please pay special attention to these.
CAUTION, IMPORTANT and STOP have the following meanings:

CAUTION

Used when injury or accidents may occur if the operating instructions, work instructions, work procedures, etc. are either NOT strictly adhered to or not carried out at all.

IMPORTANT

Used when damage to the device may occur if the operating instructions, work instructions, work procedures, etc. are either NOT strictly adhered to or not carried out at all.

STOP

Calls attention to special details or information.

**NOTE: SEE WEB (www.game-group.com)
FOR INSTRUCTION UPDATES.**

SAFETY WARNINGS

READ ALL WARNINGS BELOW. FAILURE TO DO SO COULD RESULT IN SERIOUS PERSONAL INJURY OR DEATH.

- RISK OF SUCTION ENTRAPMENT HAZARD, WHICH, IF NOT AVOIDED CAN RESULT IN SERIOUS INJURY OR DEATH.
- Do not block pump suction at the pump or in the pool as this can cause severe injury or death.
- Electrical wiring MUST be installed by a trained professional and adhere to local code and regulations.
- Avoid electric shock. DO NOT USE power extension cords.
- Connect ONLY to a Ground-Fault Circuit Interrupter (GFCI) power outlet. Consult a qualified, professional electrician for safe and proper installation of the required electrical outlet.
- Incorrectly installed equipment may fail, causing severe injuries or damage to the pump-filter system.
- Never place or submerge the filter and/or pump in water.
- Trapped air in the pump-filter system may cause the tank cover to be blown off which can result in death, serious injury, or damage to the pump-filter system. Ensure all air is out of system before operating.
- NEVER use the valve lever as a handle to carry or lift the filter.
- NEVER change the position of the Multi-Port Valve while the system is operating. ALWAYS unplug the system first.
- Install this product at least 10 feet away from the pool to prevent children from using the system to access the pool.
- Never PLUG or UNPLUG this unit from an electrical source while standing in water or with wet hands.
- NEVER service this unit with the electrical power cord connected.
- Do not use any petroleum based lubricant. Petroleum based products will destroy plastic parts.
- Do NOT operate the system while the pool is in use.
- KEEP CHILDREN AWAY from all electrical equipment.
- NEVER ALLOW CHILDREN TO OPERATE THIS EQUIPMENT.

THESE SAFETY WARNINGS ARE NOT INTENDED TO INCORPORATE ALL POSSIBLE INSTANCES FOR RISK AND/OR SEVERE INJURY.

1. THE PRODUCT

The filter with pump (drawing 1) are employed in filtering above ground and in-ground pools, where careful and expert water cleaning is required.

2. FIELD OF USE

The filter/pump is positioned at least 3.5 m from the edge of the pool. The water temperature must not exceed 35° and must not go under 4°.

Disconnect the plug before starting to do any work.

3. FILTER/PUMP INSTALLATION

The filter/plug is made up of the following parts (drawing 2):

- 1 - a pump
- 2 - a valve
- 3 - a gasket
- 4 - a closing flange
- 5 - a filter tank
- 6 - a tube with a manifold
- 7 - small sand guard filters
- 8 - a drain cock
- 9 - a spigot
- 10 - a supporting base

Before installing the filter pump unit identify the position in which it is to be installed, as once it has been filled up with sand, the filter is hard to move due to its weight.

Filter part installation

Insert the tube with the manifold into the container (drawing 3) and screw the small sand guard filters to the manifold (drawing 4).

Place the completed manifold on the foundation and fill halfway with water to stabilize it.

Place the spigot on the mouth of the container, making sure the tube is centred on the manifold. Fill halfway with sand (drawing 5).

Remove the spigot, clean the filter mouth carefully and insert the 7-way valve (drawing 6), making sure there is no sand. Insert the flange and tighten the fastening screws (drawing 7).

The filter is now ready.

4. PUMP AND WALL SKIMMER CONNECTIONS

The pump must be positioned on its special seat on the supporting base and fixed to the base with the crews it is equipped with (1 drawing 8).

- 1) Connect the OUT delivery side of the pump with the PUMP union of the valve. Use the coupling and the clamps it is equipped with (1-2 drawing 9).
- 2) Connect the Skimmer union with the IN suction of the pump.(See marking on pump.)

- 3) Connect the union of the mouth for water entry into the pool with the RETURN union of the 7-way valve.
- 4) Connect an adequate tube with the WASTE mouth when the backwash function is desired so that dirty water can be drained out to a chosen site.

All tubes must be fastened with safety clamps.

Fill up the pool – make sure the water level covers about halfway the suction mouth of the wall skimmer.

Now the system can be started up. Follow the instructions below.

5. STARTING UP THE FILTER/PUMP

- 1) Make sure the plug is disconnected. Set the lever on the BACKWASH position. Switch the pump on and carry out a backwash for a few minutes to eliminate any sand that could have settled during filling up. Switch the pump off.
- 2) Now set the lever on RINSE; switch the pump on and rinse for a minute. Switch the pump off.
- 3) Set the lever on FILTER. Switch the pump on. The filter is now operating normally and is carrying out its function at an optimum level.

We recommend you to use the filter at least twice a day for 3-4 hours and to do a backwash for a few minutes after each cycle.

6. CLEANING THE BOTTOM OF THE POOL

Switch the pump off and insert the skimmer in the special brush holder (vacuum). Make sure all the air comes out.

Set the lever on FILTER. Switch the pump on and brush the bottom and the walls. Make sure no air enters as it could defuse the pump or cause damage to it by making it work without water.

When cleaning is finished, stop the pump, turn the lever to BACKWASH, switch the pump on and wash for one minute to eliminate dirt. Switch the pump off, set the lever on RINSE, switch the pump on for half a minute for a light rinse. Cleaning operations are now finished.

7. STORING IN WINTER

At the end of the summer season, disconnect the tubes, remove water from the filter by opening the tap.

Water must also be emptied from the pump and it must be placed in a dry place, where it cannot be damaged by the cold.

The sand may be left and reused during the next season.

8. SAFETY RULES

The pump must be connected to the electric network by a 30 mA differential switch.

Always disconnect the pump from the electric network before carrying out any kind of operation on the filter or pump.

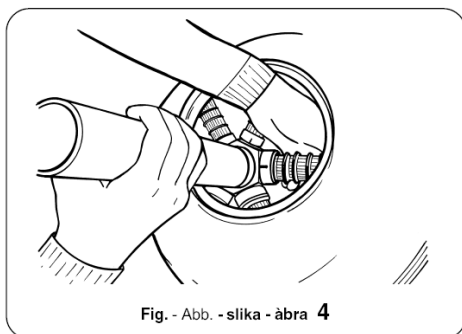
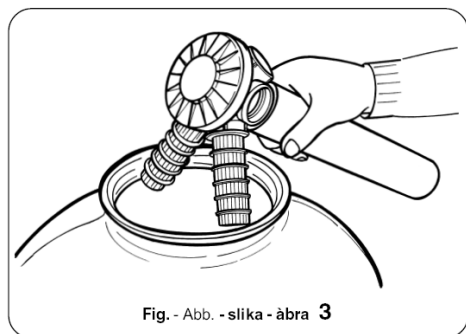
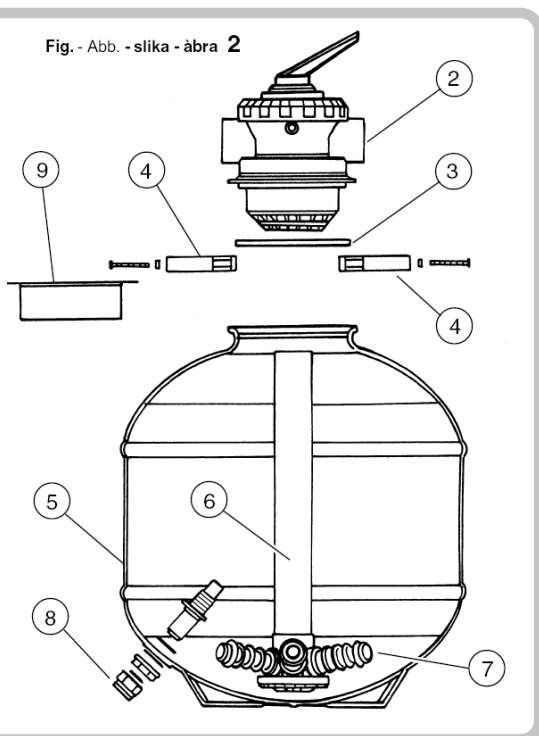
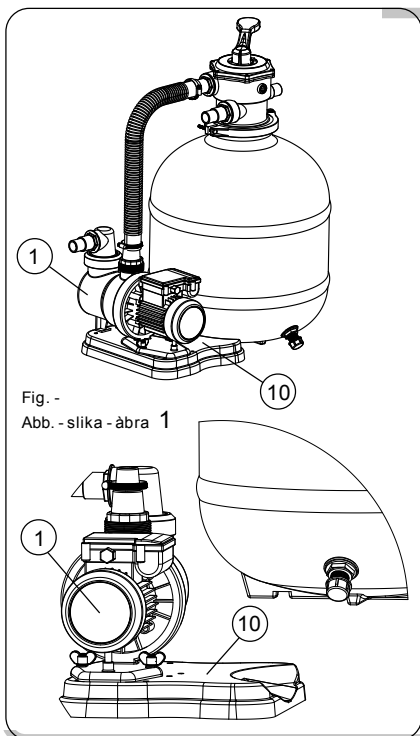

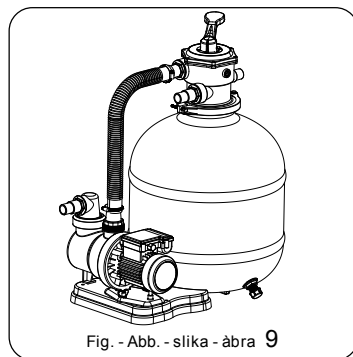
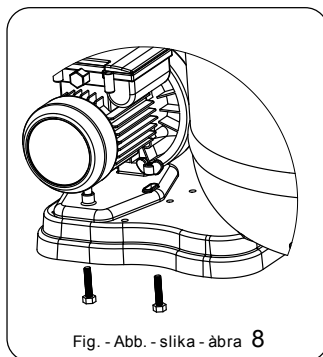
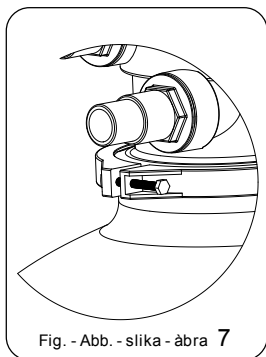
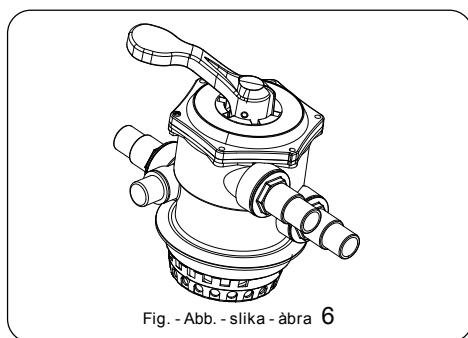
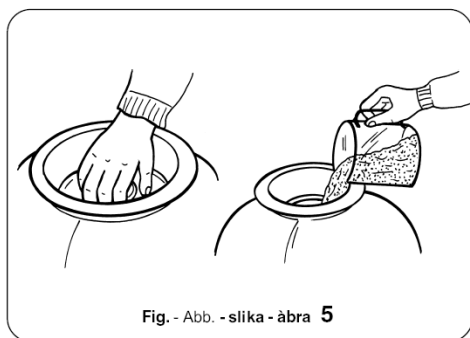

LIMITED WARRANTY STATEMENT

The manufacturer warranties safe operation and reliability only under the following conditions:
The filter system is installed and operated according to the assembly and operating instructions.
Only original replacement parts are used.

Consumable parts do NOT fall under the warranty

Expendable parts do NOT fall under the warranty. These include:

- All O-rings (40x5 mm O-ring for tank cover, 105x5 mm O-ring for pump cover, 58x6 mm O-ring for housing, 50x3 mm O-rings for hose connections, 6x2 mm O-rings for screws)
- Pressure Gauge
- Hair & Lint Strainer Basket
- Mechanical Seal, Complete
- Filter-to-Pump Hose

General Terms

This Limited Warranty applies to the enclosed product (the "Product") distributed by Great American Duck Races, Inc., an Arizona corporation (doing business as Great American Marketing and Events) ("GAME").

GAME warrants that the Product will be free from defects in materials and workmanship under normal use for a period of one (1) year from the date of purchase. (Your dated sales or delivery receipt, showing the date of your Product purchase, is your proof of the purchase date.) During the warranty period, GAME will repair or replace any defective parts at no charge.

All defective parts that are replaced by GAME will be replaced, at GAME's discretion, with either new parts or used parts that meet or exceed performance specifications for new parts. All parts removed from the Product under this warranty will become the property of GAME. Repair or replacement of any parts will not serve to extend the one (1) year warranty period.

This Limited Warranty does not apply to expendable parts. This Limited Warranty does not extend to any product (a) from which the serial number has been removed or (b) that has been damaged or rendered defective (i) as a result of accident, misuse, abuse or other external causes; (ii) by operation outside the usage parameters stated in the manual that shipped with the Product; (iii) by the use of parts not manufactured or sold by GAME; or (iv) by modification or service by anyone other than GAME or an authorized GAME distributor.

If a defect is identified within the warranty period, please contact GAME.

EXCEPT FOR THE LIMITED WARRANTY SET FORTH ABOVE, GAME EXPRESSLY DISCLAIMS ALL OTHER WARRANTIES, WHETHER EXPRESS OR IMPLIED, ORAL OR STATUTORY (INCLUDING, WITHOUT LIMITATION, WARRANTIES OF MERCHANTABILITY AND FITNESS FOR A PARTICULAR PURPOSE). ANY IMPLIED WARRANTIES THAT MAY BE IMPOSED BY LAW ARE LIMITED TO THE TERMS OF THE ABOVE LIMITED WARRANTY.

Limitation of Liability

EXCEPT FOR THE LIMITED WARRANTY DESCRIBED ABOVE, IN NO EVENT WILL GAME HAVE ANY LIABILITY OF ANY KIND WHATSOEVER (WHETHER UNDER CONTRACT, TORT, OR ANY OTHER THEORY OF LEGAL LIABILITY) TO ANY PERSON WITH RESPECT TO THE PRODUCT (INCLUDING, WITHOUT LIMITATION, (A) ANY USE OR MISUSE OF THE PRODUCT, (B) ANY FAILURE OR MALFUNCTION OF THE PRODUCT, (C) ANY BODILY INJURY, DEATH, LOSS OF OR DAMAGE TO ANY PROPERTY, OR ANY OTHER DAMAGES RELATED TO OR RESULTING FROM THE PRODUCT OR ITS USE (INCLUDING, WITHOUT LIMITATION, ANY SPECIAL, INCIDENTAL, CONSEQUENTIAL OR PUNITIVE DAMAGES, LOST PROFITS, LOSS OF USE), EVEN IF GAME OR GAME'S AUTHORIZED REPRESENTATIVES HAVE BEEN ADVISED OF THE POSSIBILITY OF ANY SUCH DAMAGES.

Severability

Any provision of this Limited Warranty which is prohibited or unenforceable in any jurisdiction will, as to such jurisdiction, be ineffective to the extent of such prohibition or unenforceability without invalidating the remaining portions hereof or affecting the validity or enforceability of such provision in any other jurisdiction.

Venue and Choice of Law

This Limited Warranty is applicable in all countries. This Limited Warranty will be governed by the laws of the State of Arizona (regardless of any conflict of laws rules), and any disputes arising from this Limited Warranty will be resolved in Phoenix, Arizona.

Entire Agreement

This Limited Warranty is understood to be the complete and exclusive agreement between GAME and the purchaser of the Product, superseding all prior agreements, oral or written, and all other communications between such parties relating to the Product. No employee or representative of GAME or any other party is authorized to make any warranty in addition to the limited warranty set forth above.

IMPORTANT
DO NOT RETURN PRODUCT TO STORE

For technical assistance and missing parts, call Customer Service toll-free

1.888.339.2546

(press 135 at any time)

Monday through Friday, 8 am to 5:00pm MST

Saturday, 8:00am to 1:00pm MST

Look for other GAME products at your favorite store
or visit our website, www.game-group.com/retailers.



Great American Merchandise & Events™
16043 N. 82nd Street
Scottsdale, AZ 85260-1800 U.S.A.

tel: 888.382.5988, 602.957.3825
fax: 602.957.7665
email: products@game-group.com
www.game-group.com/retailers