





















INSTRUCTION MANUAL

Table of Contents

Warnings2
Installation3
Water Chemistry3
Salt Instructions4
Stabilizer6
Trouble Shooting6
Startup6
Maintenance7
Winterizing8
Warranty8

IMPORTANT SAFETY INSTRUCTIONS

READ AND FOLLOW ALL INSTRUCTIONS

-  **WARNING:** To reduce the risk of injury, do not permit children to use this product unless they are closely supervised at all times
-  **WARNING:** If ambient air temperature exceeds 115° F., protect the transformer from direct sunlight with a well ventilated cover.
-  **WARNING:** To reduce the risk of fire, electrical shock, injury, or damage to your product or to bathers:
-  **WARNING:** The sole purpose of this product is for use as a salt water chlorinator; any modification or other use will void the warranty.
-  **WARNING:** Do not allow children to use, touch, or play near or around the units' power pack.
-  **WARNING:** Only connect to a GIFC outlet
-  **WARNING:** Do not connect unit to AC power until installation is complete
-  **WARNING:** Do not use if unit is damaged in any way.
-  **WARNING:** Use this product only for its intended use as described in this manual.
-  **WARNING:** Unit must be completely submerged in water or warranty is void.
-  **WARNING:** Plug only into 110 V receptacles protected by a ground fault circuit interrupter.
-  **WARNING: DO NOT USE EXTENSION CORDS, DEATH OR INJURY CAN RESULT.**
-  **WARNING:** Make sure ChlorEase is unplugged from its power supply before opening the unit or performing any other maintenance.
-  **WARNING:** To protect risk of electrical shock, do not put the transformer in water or other liquid.
-  **WARNING:** To avoid damage to the transformer and cord, never carry the transformer by the cord or yank to disconnect from an outlet. Instead, disconnect by pulling the plug itself from the outlet. Do not pull cord around sharp corners or edges.
-  **WARNING:** Do not operate with a damaged cord or transformer.
-  **CAUTION:** Disconnect transformer from outlet when not in use.
-  **CAUTION:** If ChlorEase is not working as it should or has been dropped or damaged in any way, contact RecWaterTec customer service before using at (561) 805-7778.

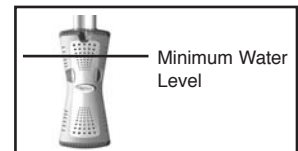

SAVE THESE INSTRUCTIONS

Introduction

ChlorEase is an automated chlorine generation system that has been specifically designed to operate in the above ground or storable pool environment. The system requires a low concentration of salt (sodium chloride) in the pool water. The salt levels are generally below the taste level of most people, but have the effect of softening the water so it feels silkier and leaves hair and skin feeling much smoother than with other chlorine chemical products.

The ChlorEase unit sanitizes your water by converting the sodium chloride (salt) in your pool to chlorine ions by electrolysis. The chlorine ions generated form hypochlorous acid, killing bacteria and algae in the pool that are then removed mechanically by the pool filter. The chlorine then reconstitutes itself as sodium chloride and begins the process from the beginning, in a virtually unending cycle, resulting in rarely having to add sanitizer to your pool again. The only way that salt is lost from the pool is through backwashing, splash out or drainage. Thus, salt replenishment is needed only periodically.

ChlorEase has been designed to introduce sanitizer 24 hours a day 7 days a week to keep your pool sparkling clear. It has been designed to work on a wide variety of pools with minimal installation time.

Installation

1) First insure that chemical levels of the pool are correct. If the composition is not correct, the unit will not be able to maintain sanitizer conditions.

2) Locate an area of the pool that will allow for convenient access to a reliable steady supply of electricity with a GFCI socket.

Note that the unit cannot be plugged into a circuit that is on a timer! This unit must have electrical supply 24hrs a day 7 days a week.

DO NOT PLUG IN YET!

3) Install ChlorEase in reasonably close proximity to filter return fitting to maximize circulation of the chlorine being produced.

4) Remove screws and caps securing the top ledge of the pool in the desired area.

5) Gently lift one end of the ledge and slide the ChlorEase unit onto the pool wall. For best results position the ChlorEase unit in the middle of the top ledge.

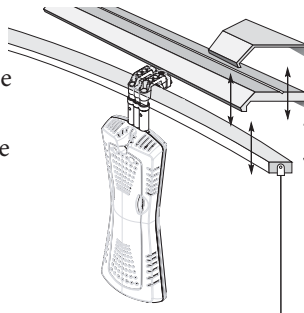

6) Turn screws on back of mounting bracket in to secure the unit against the top of the pool wall using Allen wrench provided. Simple grounding of your pool using a metal stake in the ground and a wire attached to the ground wire screw provided on the metal bracket is recommended to further minimize the risk of corrosion to metal pool parts.

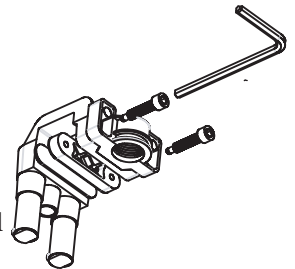

7) Replace the top rail and all hardware.

8) Plug ChlorEase in to 120vac GFCI socket.

9) Place the transformer in a protected area at least 3 feet from the pool. Bubbles should rise from submerged cell. Initially a soft milky cloud may appear around the ChlorEase unit. This will stop after a few days of use. This is normal and a good indicator that the unit is working properly.

WARNING: DO NOT OPERATE CHLORINATOR IF SALT LEVEL IS BELOW 2,500 ppm. FAILURE TO MAINTAIN PROPER SALT LEVELS IN POOL WATER MAY VOID WARRANTY.

Water Chemistry

The ChlorEase system will automate the introduction of sanitizer into your pool, but it is very important that you check and regularly maintain the chemical make up of your pool water. Table 1 shows the recommended levels to be maintained in your pool.

It is essential to maintain these levels to reduce corrosion and scaling and to maximize the life of your product. Test your water weekly or bring a sample to your local pool store so they may assist you in maintaining proper pool chemistry.

Be sure to inform the pool professional testing your water that you are using a ChlorEase salt water system. Cyanuric acid or conditioner takes a few days to totally dissolve and level off. Please monitor it closely for the first few days of operation. Cyanuric acid stabilizes the presence of chlorine in your pool water and is essential for proper disinfection.

Table 1
Optimum Water Chemistry

ITEM	RECOMMENDED LEVEL
Salt	3400 to 4000 ppm
Free Chlorine	1.0 to 4.0 ppm
pH	7.2 to 7.6
Total Alkalinity	80 to 120 ppm
Calcium Hardness	150 to 300 ppm
Cyanuric Acid	80 ppm
Metals	0 ppm

Salt Level

Refer to table 2 to determine how much salt should be added to your pool for proper performance. Use the equation below to determine the gallons or liters of water in your pool.

How to Calculate Pool Size

Pool Type	Gallons	Liters
Rectangular	Length (ft.) x Width (ft.) x Average Depth (ft.) x 7.5	Length (m) x Width (m) x Average Depth (m) x 1000
Round	Diameter (ft.) x Diameter (ft.) x Average Depth (ft.) x 5.9	Diameter (m) x Diameter (m) x Average Depth (m) x 785
Oval	Length(ft.) x Width(ft.) x Average Depth (ft.) x 6.7	Length (m) x Width (m) x Average Depth (m) x 840

The optimum salt level is between 3600 and 4000ppm. The salt level can easily be checked using test strips commonly sold at your local pool store. If the salt level is low, use Table 2 to determine how much salt must be added to achieve the desired level.

On Table 2 first locate on the top row the gallonage of your pool. Then look in the first column marked current salt level and find your current salt level. Follow that row over to where it intersects with your pool gallon column. The number in that box shows the number of pounds of salt you must add in order to achieve the ideal salinity.

Remember that the only way that your pool will lose salt is if:

- You backwash your filter • Splash out • Overfill the pool • Drain the pool

Type of Salt to Use

It is imperative that you use only sodium chloride (NaCl) that is 99% pure. This is commonly available at most reputable pool stores or home centers in 50lbs bags. Do not use rock salt, salt with more than 1% yellow prussiate of soda, salt with more than 1% anti caking additives. DO NOT USE IODIZED SALT.

Adding Salt

Turn pool filter on and add salt directly to the pool. Use a brush to dissolve and disperse salt throughout pool. A pool vacuum or robotic pool cleaner will serve the same purposes. Run the pump for the next 24 hours using the main drain for suction. If no main drain is available, use the pool vacuum. Do not add salt through your skimmer; add directly into pool and brush to dissolve.

Removing Salt

The only way to remove salt or lower salinity is to drain water off and fill with fresh water.

Table 2

**LBS OF SALT REQUIRED TO RAISE LEVELS 4000ppm
(KG) OF SALT REQUIRED TO RAISE LEVELS 4000ppm**

Current Salt level	6,000 gal (22,500 L)	8,000 Gal (30,000 L)	10,000 Gal (37,500 L)	12,000 Gal (45,000 L)	14,000 Gal (52,500 L)	16,000 Gal (60,000 L)	18,000 Gal (67,500 L)
0	200 (93)	256 (115)	335 (153)	400 (181)	465 (214)	535 (242)	600 (274)
200	190 (88)	243 (109)	318 (145)	380 (172)	442 (203)	508 (230)	570 (260)
400	180 (83)	230 (103)	301 (137)	360 (163)	419 (192)	481 (218)	540 (246)
600	170 (78)	227 (97)	284 (129)	340 (154)	396 (181)	454 (206)	510 (232)
800	160 (73)	213 (97)	267 (121)	320 (145)	373 (170)	427 (194)	480 (218)
1000	150 (69)	200 (91)	250 (114)	300 (136)	350 (159)	400 (182)	450 (205)
1200	140 (64)	187 (85)	233 (106)	280 (127)	327 (148)	373 (170)	420 (191)
1400	130 (59)	173 (79)	217 (98)	260 (118)	303 (138)	347 (158)	390 (177)
1600	120 (55)	160 (72)	200 (91)	240 (109)	280 (127)	320 (145)	360 (164)
1800	110 (51)	147 (66)	183 (83)	220 (100)	257 (117)	293 (133)	330 (150)
2000	100 (46)	133 (60)	167 (76)	200 (91)	233 (106)	267 (121)	300 (136)
2200	90 (41)	120 (54)	150 (68)	180 (82)	210 (95)	240 (109)	270 (123)
2400	80 (36)	107 (48)	133 (61)	160 (73)	187 (85)	213 (97)	240 (109)
2600	70 (32)	93 (42)	117 (53)	140 (64)	163 (74)	187 (85)	210 (95)
2800	60 (27)	80 (36)	100 (45)	120 (55)	140 (64)	160 (73)	180 (82)
3000	50 (23)	67 (30)	83 (38)	100 (45)	117 (53)	133 (61)	150 (68)
3200	40 (18)	53 (24)	67 (30)	80 (36)	93 (42)	107 (48)	120 (55)
3400	30 (14)	40 (18)	50 (23)	60 (27)	70 (32)	80 (36)	90 (41)
3600	20 (9)	27 (12)	33 (15)	40 (18)	47 (21)	53 (24)	60 (27)
3800	10 (4)	13 (6)	17 (8)	20 (9)	23 (11)	27 (12)	30 (14)
4000	0	0	0	0	0	0	0
4200	Dilute	Dilute	Dilute	Dilute	Dilute	Dilute	Dilute

 **WARNING:** DO NOT OPERATE CHLORINATOR IF SALT LEVEL IS BELOW 2,500 ppm. FAILURE TO MAINTAIN PROPER SALT LEVELS IN POOL WATER MAY VOID WARRANTY.

Stabilizer (Cyanuric Acid)

When checking salt level, always check the level of Cyanuric acid as well since it is likely that they will decline together. Use chart 3 to determine how much stabilizer must be added to raise levels to the optimum level of 80ppm. First find the column that represents the gallons or liter of your pool. Then locate the row that shows your current level of Cyanuric Acid. The box that intersects those two will tell you the lbs or (kg) needed to raise levels in your pool to 80ppm. Remember that Cyanuric Acid or conditioner takes some time to dissolve so check levels for several days after adding, or before adding more.

Chart 3
POUNDS AND (KG) OF STABILIZER (CYANURIC ACID)
NEEDED TO RAISE LEVELS TO 80 PPM

Current Stabilizer	6,000 gal (22,500 L)	8,000 Gal (30,000 L)	10,000 Gal (37,500 L)	12,000 Gal (45,000 L)	14,000 Gal (52,500 L)	16,000 Gal (60,000 L)	18,000 Gal (67,500 L)
0 ppm	4.0 (1.8)	5.3 (2.4)	6.7 (3.0)	8.0 (3.6)	9.4 (4.3)	10.7 (4.9)	12.0 (5.4)
10 ppm	3.5 (1.6)	4.7 (2.1)	5.8 (2.6)	7.0 (3.2)	8.2 (3.7)	9.4 (4.3)	10.5 (4.8)
20 ppm	3.0 (1.4)	4.0 (1.8)	5.0 (2.3)	6.0 (2.7)	7.0 (3.2)	8.0 (3.6)	9.0 (4.2)
30 ppm	2.5 (1.1)	3.3 (1.5)	4.2 (1.9)	5.0 (2.3)	5.9 (2.7)	6.7 (3.0)	7.5 (3.4)
40 ppm	2.0 (0.9)	2.7 (1.2)	3.3 (1.5)	4.0 (1.8)	4.7 (2.1)	5.4 (2.4)	6.0 (2.7)
50 ppm	1.5 (0.7)	2.0 (0.9)	2.5 (1.1)	3.0 (1.4)	3.5 (1.6)	4.0 (1.8)	4.5 (2.0)
60 ppm	1.0 (0.5)	1.3 (0.6)	1.7 (0.8)	2.0 (0.91)	2.4 (1.1)	2.7 (1.2)	3.0 (1.4)
70 ppm	0.5 (0.2)	0.7 (0.3)	0.8 (0.4)	1.0 (0.45)	1.2 (0.54)	1.4 (0.64)	1.5 (0.68)
80 ppm	0.0	0.0	0.0	0.0	0.0	0.0	0.0

Startup and Spring Opening

Add ChlorEase Boost or another saltwater- compatible chlorinating product initially to bring chlorine level to 3 ppm. This is likely the only time you'll need to add chlorine to your pool. This will charge the water with chlorine as the ChlorEase begins to generate chlorine in the pool. ChlorEase will then maintain your chlorine level after the initial shock treatment.

Troubleshooting

If bubbles are not rising from the submerged part of the unit, follow these troubleshooting tips:

1. Unplug the unit and verify that you have power at the socket. Use a voltmeter to determine that you have 115vac output from the socket. If a voltmeter is not available, use a lamp or other appliance to verify that there is enough voltage being supplied to the socket. If there is no supply voltage, either repair the socket or plug the ChlorEase in elsewhere.
2. If the socket is active, call 1-561-805-7778 for service.

Maintenance of your ChlorEase System

Adding Salt

Begin by testing the salt levels of the pool using saline test strips available at your local pool store. The salt level must be above 3600ppm. If the salt level is low, refer to Table 2 for amount of salt to add.

Cleaning the Cell DO NOT REMOVE THE MESH COVERING THE CELL! INSIDE ELEMENT IS SHARP!

If proper chlorine levels cannot be maintained, and if salt levels and pH readings are correct, the cell must be cleaned. **FIRST UNPLUG THE CHLOREASE UNIT FROM THE AC SOCKET. THE UNIT SHOULD ONLY BE SERVICED AFTER IT HAS BEEN UNPLUGGED.**

Remove the ChlorEase housing from the pool by pushing in the retaining clips to unlock the housing from the metal bracket, using the plastic tool provided. Grasp the housing and pull down, detaching it from the metal bracket. Remove the front cover from the housing by first unscrewing the two plastic screws on the front using the plastic key provided, and then grasp the two side clips to remove the front cover. Next, pull out the wire spool and unwind the excess cord allowing the housing to be pulled over outside of pool. Visually inspect the metal elements inside the mesh covering of the chlorinating cell. If heavy scale is present, the scale should be removed (see next section).

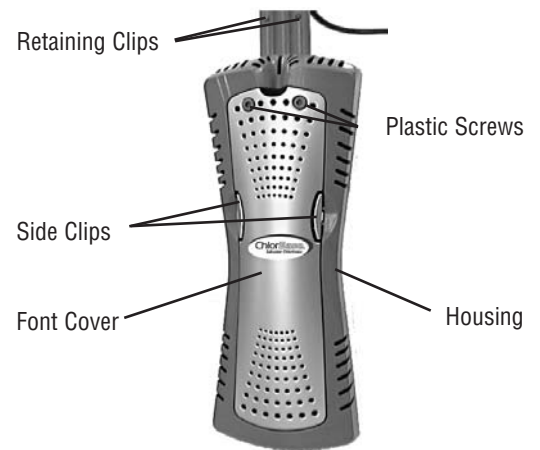

Removing Scale from Elements

Unsnap chlorinating cell from housing. Fill a deep container such as the milk carton with ChlorEase Clean or a similar mildly acidic product. Immerse the chlorinating cell only (NOT the housing) and let it set for 45 minutes. Hose off and inspect cell.

All scale (cake-like white mineral buildup) should have dissolved. If scale remains, change cleaning solution and repeat process. **DO NOT SCRAPE SCALE WITH ANY TYPE OF TOOLS OR BRUSHES AS IT WILL DAMAGE TITANIUM COATING AND VOID WARRANTY!**

To reinstall, rewind extra wire around spool neatly. Replace cell into housing. Replace locking pin and replace front cover. Plug unit into GFCI outlet.

Pushing in retaining clips with plastic tool (provided)



Detaching housing from bracket

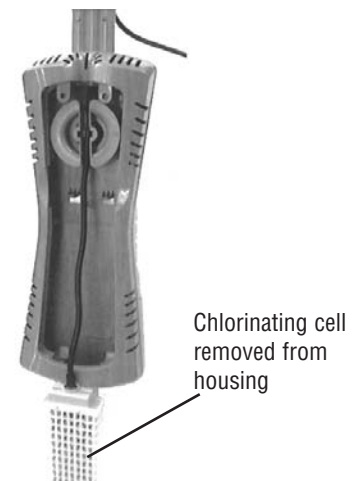

Winterizing

It is preferable to remove the entire ChlorEase system for winter. Simply reverse the installation procedure and store the system in a shed or garage. ALWAYS CLEAN THE CELL BEFORE WINTER!

If you do not remove the entire system for winterization, the ChlorEase housing and cell **must** be removed from the pool. The unit will be damaged if left in freezing water and should be removed following the instructions for cleaning the cell (above).

Use some twine or wire ties to attach the housing and cell securely to the cable that holds the cover onto the pool. Secure it in a way that the housing and cell will not swing around in the wind and cause damage.

NOTE: FAILURE TO REMOVE CELL FROM WATER FOR WINTERIZATION WILL VOID WARRANTY

Regular Water testing

Test your pool water weekly just as you would with any chemical maintenance program for your pool. The production of chlorine by ChlorEase is directly affected by how well water balance is maintained (pH, Total Alkalinity and Calcium Hardness). IF PROPER WATER BALANCE IS NOT MAINTAINED, CORROSION AND/OR SCALING CAN OCCUR IN THE ENTIRE POOL ENVIRONMENT.

ChlorEase Chemicals

RecWaterTec Offers a full line of ChlorEase brand salt water-compatible pool chemicals. See your swimming pool dealer or visit our website at www.recwatertec.com for more information.



THREE YEAR LIMITED WARRANTY ChlorEase

Three year limited warranty from date of original purchase for manufacturing defects under normal and reasonable use, and subject to the maintenance requirements and installation guidelines set forth in the product instruction manual. This warranty covers full replacement of the product for one year from the original purchase date of the product; 50% of the MSRP will be payable by the purchaser towards replacement of the product after one year from original purchase date until the end of the second year; 75% of the MSRP will be paid by the purchaser towards replacement of the product after two years from original purchase date until the end of the third year.

THIS WARRANTY IS SUBJECT TO THE TERMS, LIMITATIONS AND EXCLUSIONS DESCRIBED BELOW, AND THERE ARE NO OTHER WARRANTIES OR REPRESENTATIONS, EITHER EXPRESS OR IMPLIED, WHETHER OF MERCHANTABILITY, FITNESS FOR A PARTICULAR PURPOSE, OR OTHER, MADE BY THE MANUFACTURER, OTHER THAN THOSE SPECIFICALLY SET FORTH IN THIS WRITTEN WARRANTY

What is Covered: Recreational Water Technologies, LLC (RecWaterTec) warrants its electronic product to be free from defects in material and workmanship when leaving the factory.

What is not Covered: Any type of damage to the product due to improper installation, maintenance, or failure to provide necessary and reasonable maintenance; any damage or injury caused by misuse and/or unreasonable use of the product; batteries (if applicable); damage due to or related to improper draining, winterizing, storage or Acts of God; RecWaterTec will not honor any claims for damage to any products in transit unless damage to the shipping container is noted at the time of delivery on the transfer company's delivery bill.

THE WARRANTY OBLIGATIONS OF RECWATERTEC ARE LIMITED TO REPAIR OR REPLACEMENT OF THE PRODUCT OR OF ANY DEFECTIVE COMPONENT, AT THE OPTION OF RECWATERTEC. UNDER NO CIRCUMSTANCES WILL RECWATERTEC BE LIABLE OR RESPONSIBLE FOR ANY CONSEQUENTIAL OR INCIDENTAL DAMAGES, AND/OR CHARGES FOR LABOR. RECWATERTEC SHALL NOT BE LIABLE OR RESPONSIBLE UNDER ANY CIRCUMSTANCES OR ANY AMOUNT FOR ANY CONSEQUENTIAL OR INCIDENTAL DAMAGES, OR FOR ANY INJURIES OR DAMAGES TO PERSON OR PROPERTY USING OR USED IN CONNECTION WITH THE PRODUCT, OR FOR ANY OTHER LOSS OF PROFITS OR OTHER COSTS OR EXPENSES OF ANY KIND OR CHARACTER. IF RECWATERTEC DETERMINES THAT EITHER REPAIR OR REPLACEMENT OF THE PRODUCT IS NECESSARY, RECWATERTEC MAY EITHER REPAIR THE PRODUCT AT A NOMINAL CHARGE TO THE OWNER OR REPLACE THE PRODUCT AS PER THE REPLACEMENT COST SCHEDULE DESCRIBED ABOVE. RECWATERTEC RESERVES THE RIGHT TO SUPPLY REFURBISHED PRODUCTS OR PARTS. THE OWNER BEARS THE SOLE RESPONSIBILITY FOR PRE-PAID RETURN OF THE PRODUCT TO RECWATERTEC, AND ALL REPAIRED OR REPLACED PRODUCTS WILL BE RETURNED AT THE OWNER'S EXPENSE.

NO PERSON, FIRM, OR CORPORATION IS AUTHORIZED TO MAKE REPRESENTATIONS OR INCUR ANY OBLIGATIONS IN THE NAME OF OR ON BEHALF OF RECWATERTEC, EXCEPT AS STATED HEREIN. THE REMEDIES SET FORTH IN THIS WARRANTY ARE EXPRESSLY UNDERSTOOD TO BE THE EXCLUSIVE REMEDIES AVAILABLE TO THE OWNER, AND THIS WARRANTY CONTAINS THE FULL AND COMPLETE AGREEMENT BETWEEN RECWATERTEC AND THE OWNER. THIS WARRANTY SETS FORTH THE ONLY OBLIGATIONS OF RECWATERTEC, WITH REGARD TO THIS PRODUCT, AND THERE ARE NO WARRANTIES WHICH EXTEND BEYOND THE DESCRIPTION ON THE FACE HEREOF.

The representations set forth herein are the only representations made by RecWaterTec, with respect to the product, and this warranty does not constitute either a performance or satisfaction guarantee. It is the responsibility of the product owner to regularly test and check the product for proper function and safety.

This warranty gives the original owner specific legal rights. You may have other rights depending on where you live.

What you must do to file a claim: Call 1-561-805-7778 to initiate a claim.