

VEGA™

Battery Rechargeable Umbrella Light

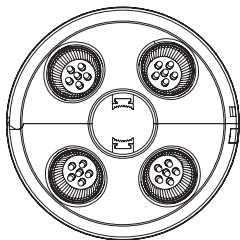

8" VEGA

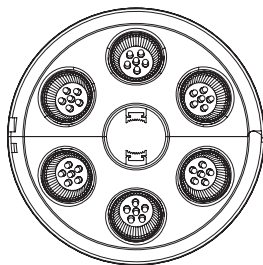

9" VEGA-L

ASSEMBLY AND OPERATION

Thank you for your purchase of either **Treasure Garden's VEGA or VEGA-L** battery rechargeable umbrella light. Please remove all contents from the package, inspect and review checklist for all parts. **CAUTION:** To reduce personal injury and damage to your umbrella light, read and follow this Assembly and Operation information.

C H E C K L I S T :

- A** - On/Off Button
- B** - Clamp Release Button
- C** - Battery Pack (Batteries included)
- D** - Battery Charger

VEGA™

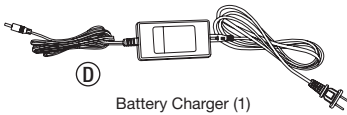
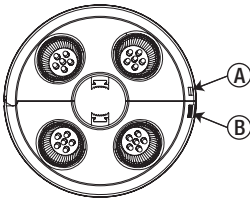
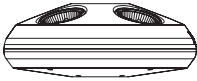

Size: 8" diameter
 Available colors:
 Champagne or Bronze
 Lights: 24 LED lights
 AC Charger: 110V
 Charge time: 6 Hrs.
 (Lights up to 5 hrs. with a fully charged battery.)

VEGA-L

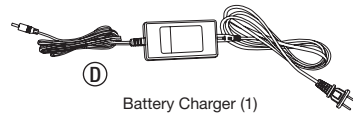
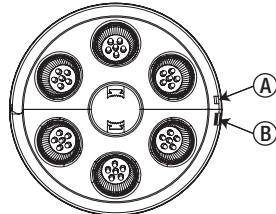
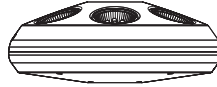

Size: 9" diameter
 Available colors:
 Champagne or Bronze
 Lights: 36 LED lights
 AC Charger: 110V
 Charge time: 6 Hrs.

ASSEMBLY :

No assembly is required for the VEGA™ battery rechargeable light however, you must fully charge the VEGA battery prior to first use.

To OPEN the VEGA Umbrella Light:

1. Open the VEGA umbrella light by holding firmly with one hand and then depress the clamp release button with the other hand to release the clamp lock (Fig. 1).

To CHARGE/RECHARGE the VEGA Umbrella Light:

1. With the VEGA umbrella light opened, slide back the battery release button to remove the battery pack from its compartment (Fig. 2).
2. After removing the battery pack, plug the charger into the battery input (Fig. 3), then plug charger into 110V electrical outlet for 6 hours to fully charge.
3. After battery charging is complete, gently slide battery pack back into compartment until battery pack snaps into place.

NOTE: Only use the supplied battery charger, charging the light with a substitute charger may damage the battery pack or cause overheating, which could result in personal injury and/or other damages.

To TURN ON and TURN OFF the VEGA Umbrella Light:

1. Depress the On/Off button to turn on and turn off LED lights.

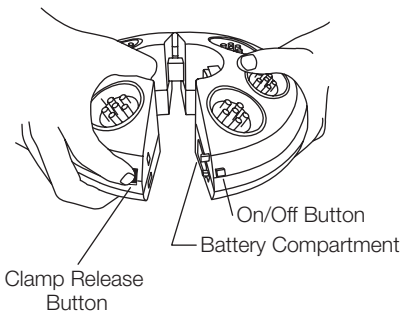

(Fig. 1)

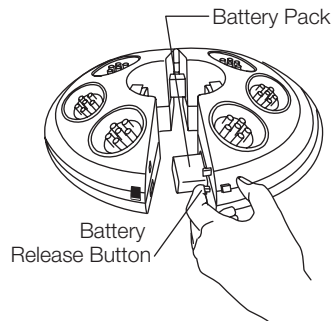

(Fig. 2)

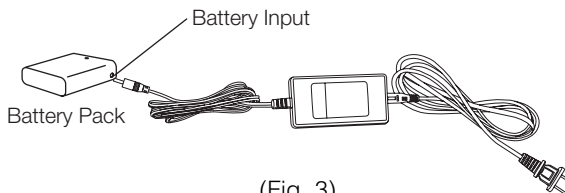

(Fig. 3)

O P E R A T I O N :

To OPEN and ATTACH the VEGA™ Umbrella Light:

1. Open the VEGA umbrella light by holding the light firmly with one hand and then depress the clamp release button with the other hand to release the clamp lock.
2. Open up the VEGA light and clasp around the mid pole.
3. Snap to close.

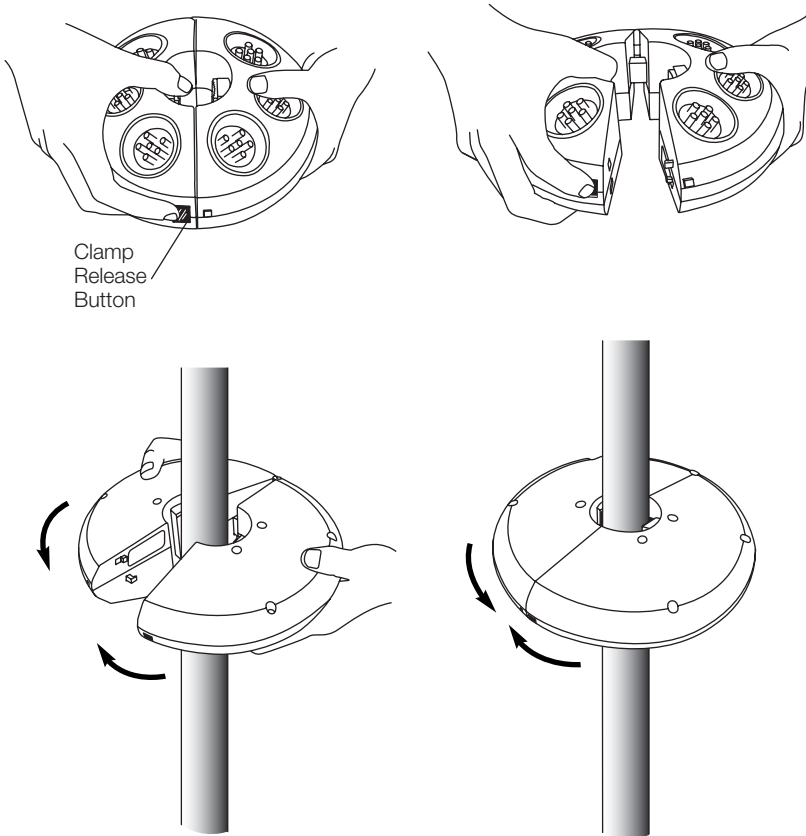

FEATURE :

TWO LIGHT DISPLAY OPTIONS:

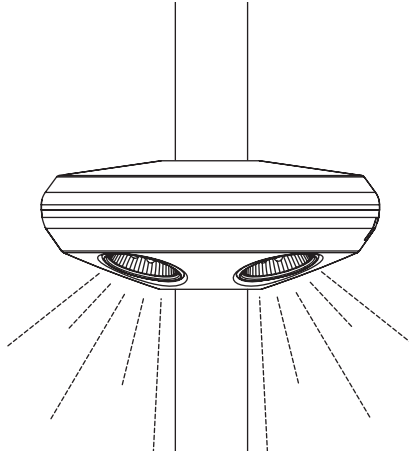

DOWNLIGHT Position:

Place the VEGA™ with LED lights facing down for dining, games, and casual reading.

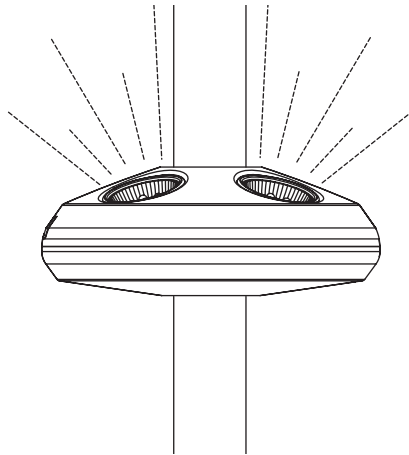

UPLIGHT Position:

Place the VEGA with LED lights facing up for indirect lighting and mood setting.

ADDITIONAL FEATURE :

In addition, starting in Spring 2008 the VEGA™ umbrella light can be attached to the VEGA™ (Pull-down) light adapter available on Treasure Garden cantilever umbrellas.

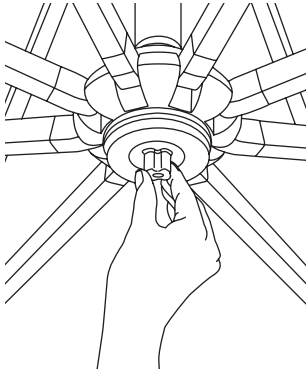

(Fig. 4)

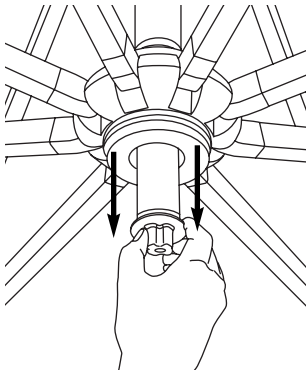

(Fig. 5)

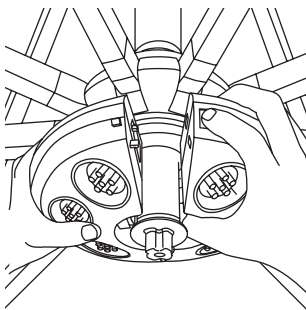

(Fig. 6)

To ATTACH VEGA Umbrella Light:

1. Loosen the VEGA light adapter built into the umbrella runner by turning counter-clockwise (Fig. 4).
2. After loosening, pull down light adapter post (Fig. 5) to attach the VEGA umbrella light.

To OPEN and ATTACH VEGA:

1. Open the VEGA umbrella light by holding firmly with one hand and then depress the clamp release button with the other hand to release the clamp lock.
2. Open up the VEGA light and clasp around the light adapter post (Fig. 6).
3. Snap to close (Fig. 7).

To REMOVE VEGA and CLOSE adapter:

1. Hold the VEGA umbrella light, depress the clamp release button to release the clamp lock.
2. Remove VEGA umbrella light, and gently push up the light adapter post back into umbrella runner and tighten turning clockwise (Fig. 4).

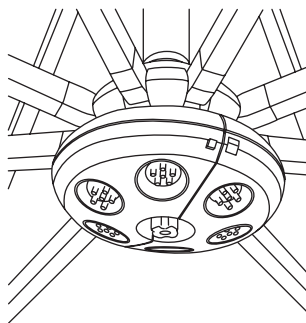

(Fig. 7)

WARRANTY:

Treasure Garden warrants this product (in residential use) to be free from defects in original materials and workmanship for a period of 1 year from the date of purchase.

If a defect in the original material or workmanship appears during the warranty period; Treasure Garden will (at its option) repair or replace the product without charge.

Simply contact your original authorized Treasure Garden dealer with a description of the defect. The dealer will verify the defect and work closely with Treasure Garden to obtain the necessary service. In many cases, simple problems can be solved with a replacement part that can be shipped directly to the dealer for professional installation / repair.

In the event that warranted factory service is required, Treasure Garden will assume the responsibility of the return freight charges on warranted product for the first year only.

Returned product that (upon receipt and inspection) is deemed to be "not covered" under our warranty, will be shipped / billed at your expense.

This warranty gives you specific legal rights, and you may have other rights which vary from state to state.

NOTE: Failure caused by unreasonable or abusive use, or failure caused by neglect of reasonable and necessary care are not covered by this warranty.

Additionally, acts of nature (including but not limited to wind, hurricanes, tornadoes, and storms) are not covered by this warranty.

S A F E T Y P R E C A U T I O N S :

- If unit is exposed to light moisture, light to medium rain; allow unit to air dry for 24 hours before reuse.

WARNING: *The VEGA™ umbrella light is not waterproof.* If the light is immersed in a pool or spa or exposed to heavy rain the unit will be damaged and negate the 1 year warranty.



www.treasuregarden.com