

AQUA SOLAR™

Electronic Solar Control Center



Operation and Installation Manual

for models

AQ-SOL-LV

AQ-SOL-LV-TC

AQ-SOL-LV-SP

GOLD LINE
CONTROLS INC.

www.goldlinecontrols.com
888-921-7665

IMPORTANT SAFETY INSTRUCTIONS

When using this electrical equipment, basic safety precautions should always be followed, including the following:

- **READ AND FOLLOW ALL INSTRUCTIONS**
- Disconnect all AC power during installation.
- Warning – To reduce the risk of injury do not permit children to use this product unless they are closely supervised at all times.
- A green colored terminal marked “EARTH” is located inside the wiring compartment. To reduce the risk of electrical shock, this terminal must be connected to the grounding means provided in the electrical supply service panel with a continuous copper wire equivalent in size to the circuit conductors supplying the equipment.
- All field installed metal components such as rails, ladders, drains, or other similar hardware within 3 meters of the pool, spa or hot tub shall be bonded to the equipment grounding bus with copper conductors not smaller than 8 AWG US/ 6 AWG Canada.

SAVE THESE INSTRUCTIONS

Table of Contents

SPECIFICATIONS

Specifications	1
----------------------	---

OPERATION

Controls	2
Temperature Display	3

INSTALLATION

Mounting	4
Wiring	4
Jumper Settings	9

TROUBLESHOOTING

Troubleshooting	10
-----------------------	----

WARRANTY

Five Year Limited Warranty.....	12
---------------------------------	----

Aqua Solar Digital Solar Control System

The Aqua Solar Digital Solar Control System is a differential temperature control for solar heating of pools, spas, and hot tubs. The Aqua Solar is available in 3 models; AQ-SOL-LV, AQ-SOL-LV-TC and AQ-SOL-LV-SP. These models provide differential temperature control with an adjustable calibrated water temperature high limit. Both offer a built-in digital display for solar, water, and ambient temperature information as well as programmable set point temperature. Automatic nocturnal cooling (for pools that overheat in hot climates) and recirculate freeze protection functions can be enabled/disabled via internal jumpers. The AQ-SOL-LV-TC additionally provides a filter pump time clock, programmable in 15-minute intervals with multiple ON/OFF times. The AQ-SOL-LV-SP model provides a solar priority function—one of the optional high voltage relays can be used to remove power from the conventional heater whenever solar heating is available. This maximizes the heat contribution from solar. Front panel indicator LED's also provide immediate feedback of system state such as heating, cooling, and sensor fault.

Specifications

Power: 105-130VAC, .5A 50/60Hz. or
195-250VAC, .3A 50/60Hz

Valve Output: 24VAC, 20VA, .85A max.
Industry standard 3 pin connector

Relay Outputs: DPST isolated contacts; 3HP@240V, 1.5HP@120V, booster pump, pool sweep interlock, or filter pump; 1 relay supplied with AQ-SOL-LV-TC, maximum of 2; order relays separately (part no. AQ-RELAY); relays are industry standard

Sensors: 2 required for "SOLAR" and "POOL" temperatures; 3rd sensor ("AUX") is optional—for display and/or recirculate freeze protection; (all sensors are thermistor type, 10K@25°C/77°F, additional freeze snap switches may be wired in series with the "AUX" sensor when used for recirculate freeze protection)

Field Selectable options

C/F	Temperature display in Celsius or Fahrenheit (factory default)
Cooling	Enables or disables (factory default) operation to cool the pool
Recirc. Frz.	Enables or disables (factory default) recirculate freeze protection
Solar Override	Enables or disables (factory default) override of the filter pump relay when solar heat is available.

Control Logic

Heat diff.:	4°F on, 1.5°F off
High Limit:	70-104°F calibrated scale
Recirc. freeze:	On when AUX sensor less than or equal to 34°F Off when AUX sensor greater than or equal to 36°F
Cool diff.:	-8°F on, -3°F off

OPERATION

The Aqua Solar is a fully automatic solar heating control which requires minimal set up or adjustment under normal operating conditions. Typically the following is required:

1. Set the main switch to AUTO
2. Set the “Desired Temperature” knob to the desired temperature for the pool
3. Set the time clock for the correct time, the desired hours of filtration, and “auto” operation (model AQ-SOL-LV-TC only)

The “Heating” LED will show when the pool is being solar heated. If your pool has a pool sweep, the Aqua Solar will turn it off for approximately 6 minutes when solar heat is turned on. This will allow air to be purged from the system.

Controls and Displays

MAIN SWITCH

ON: The Aqua Solar directs water through the solar collectors regardless of desired temperature setting. Both the “Heating” and “Cooling” LED’s will be on. For model AQ-SOL-LV-TC, this also turns on the filter pump.

AUTO: For normal operation. In this position, the Aqua Solar will operate automatically based on the solar and pool temperatures.

OFF: The Aqua Solar ceases solar heating or cooling (if enabled). Recirculate freeze protection (if enabled) will still operate normally. This switch does NOT remove power from the unit--to service the equipment, disconnect power at the main circuit breaker.

DESIRED TEMPERATURE

Set the desired pool temperature. The digital display will show the exact temperature while rotating the Desired Temperature knob. The display reverts back to the default pool temperature display a few seconds later.

TIMECLOCK (model AQ-SOL-LV-TC only)

The time clock controls the hours of operation for the filter pump. The pump can be programmed in 15-minute intervals with multiple on/off periods per day. Per NSPI standards, the pump should run long enough each day to filter all of the water in the pool each day.

Set the Aqua Solar timeclock to the correct time by rotating the clock dial in a clockwise direction. The internal “hands” show time at a glance and the arrow (approximately 2 o’clock on dial) point indicates AM/PM. Set the pump on/off time using the series of small slide “trippers” located around the outside of the timeclock. Each tripper controls a 15-minute interval.

OFF - Push trippers IN (toward center)

ON - Pull trippers OUT (away from center)

TIME CLOCK--MANUAL CONTROL

The manual control can override the timer and is located at approximately the 4 o'clock position.

- “1” (up) - pump ON
- “ ” (center) - timer controls pump
- “0” (down) - pump OFF

NOTE: If the solar override function is enabled, then the Aqua Solar may keep the filter pump running even though the time clock is “off”

TEMPERATURE DISPLAY

The temperature display normally displays the pool temperature. Push the small button next to the display to cycle through the various displays. If a temperature sensor is not wired to the Aqua Solar, or the sensor is not functioning properly, the error message "Err" will be displayed for that sensor. If the button is not pushed for 30 seconds, the display will automatically revert back to pool temperature. The example below shows a typical display:

Normal, default display indicates **P**ool temperature:

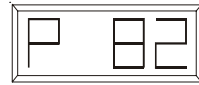

1st button push will show **S**olar Collector temperature:

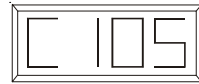

2nd button push will show **A**ux temperature (if used):

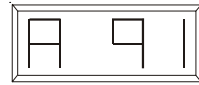

3rd button push will show "Desired Temperature":

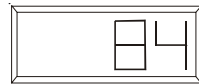

4th button push will show software revision number:

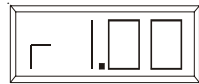

5th button push will loop back to show Pool temperature.

LED INDICATORS

- Power:** Input power is applied to the Aqua Solar.
- Heating:** Solar heating is active. If both Heating and Cooling are on, the switch is in the ON position.
- Cooling:** Nocturnal Cooling is active. If both Heating and Cooling are on, the switch is in the ON position.
- Sweep Interlock:** The pool sweep is turned OFF for approximately 6 minutes to allow air to purge from the system.
- Pool Sensor:** A problem is detected with the pool sensor (open or short circuit).
- Solar Sensor:** A problem is detected with solar sensor (open or short circuit).
- Aux Sensor:** A problem is detected with the AUX sensor (short circuit, only when used for recirculate freeze protection).

INSTALLATION

Mounting

The Aqua Solar is designed for outdoor use. Mount the enclosure vertically with the knockouts facing downward. For safety, the Aqua Solar must be a minimum of 5 feet (horizontally) from the pool or spa.

Power input

Turn off power at circuit breaker before wiring. Follow NEC and all local electrical codes. Wire to either 120VAC or 240VAC per the diagram below. If the Aqua Solar is being powered from the same circuit as one of the pumps, wire to the relay first and then jumper over the Aqua Solar terminal block. Do NOT use the Aqua Solar terminal block as a junction for pump power, the terminal block is not rated for high amps. Be sure to connect the earth ground to the green terminal.

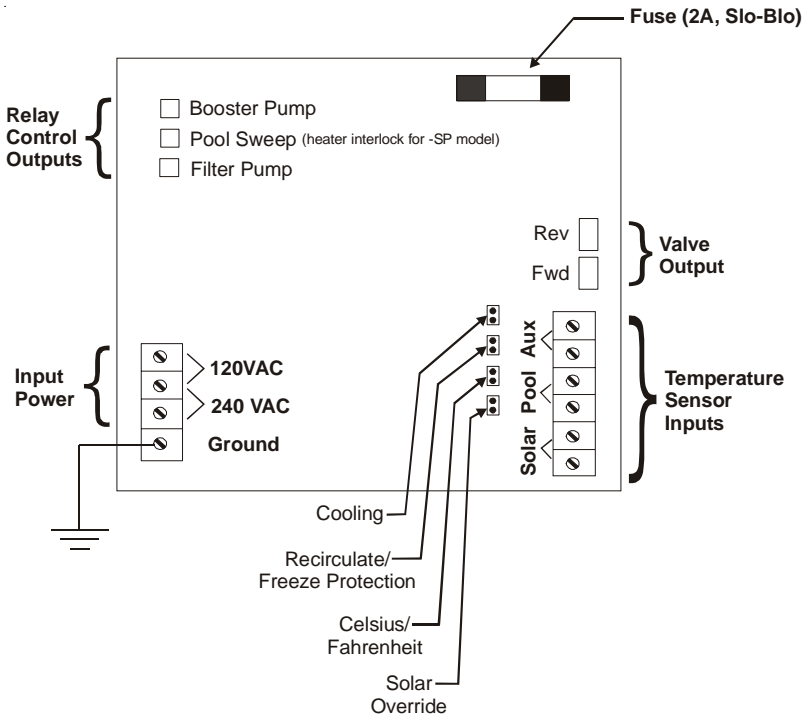

Output wiring to solar diverter valve

Most installations use a solar valve, which diverts water through the collector panels when solar heat is available. For Goldline[®], Jandy[®], and Compool[®] valve actuators (with wire end connectors), two 3-pin connectors are supplied. Plug the actuator into one of the Aqua Solar's two 3-pin connectors (see diagram above for location of connectors). If the valve operates opposite to the way it is supposed to, disconnect and plug into the other connector.

Jandy[®] is a registered trademark of Waterpik Technologies, Inc.

Compool[®] is a registered trademark of Pentair Pool Products, Inc.

Sensor Mounting and Wiring

Most installations use a Goldline "PC" type sensor for both the "SOLAR" sensor and "POOL" sensors. **The "AUX" sensor is required for optional recirculate freeze protection (see description of this function on page 9).** Otherwise, the "AUX" sensor can simply display the ambient air temperature.

Any 10K ohm Goldline sensors may be used. Wire should be twisted pair 20AWG. Sensor wiring run outdoors must be rated for outdoor use and ensure that the wire connectors are protected from the weather. For long runs or runs near other electrical wiring use shielded cable (Belden 8428 for outdoor use). Ground the shields to the Aqua Solar's ground screw.

High Voltage Relay Output Wiring

A maximum of two high voltage relays (industry standard) may be added to the AQ-SOL-LV. The AQ-SOL-LV-TC model comes with one relay for the filter pump control already installed and one additional relay may be added. Order additional relays separately (Goldline p/n "AQ-RELAY"). The relays are industry standard and are double pole, single throw meaning that they can make/break both legs of a 240VAC circuit. Screw the relays into the mounting bracket and connect the coil to the proper connector for these desired functions:

BOOST: This relay controls a booster pump for systems where the main filter pump does not have enough power to pump water through the collector array. The boost pump turns on 30 seconds after solar heating/cooling turns on.

AQ-SOL-LV: For most systems, simply connect the Aqua Solar power to the LOAD side of the filter pump timer. If the Aqua Solar is connected to LINE power (typically when "Recirculate Freeze" or "Solar Override" features are also being used), then the input power to the boost pump relay should be connected to the LOAD side of the filter pump timer. See wiring diagram on page 6 (bottom).

AQ-SOL-LV-TC: The Aqua Solar will automatically ensure that the filter pump is running before turning on the boost pump. See wiring diagram on page 7.

SWEEP INTERLOCK: The relay is wired in series with the pool sweep and turns the pool sweep off for approximately 6 minutes whenever the solar turns on. This prevents the pool sweep pump from losing prime while air is being purged from the solar collector array. For model, AQ-SOL-LV-TC the relay will also turn the pool sweep off whenever the filter pump is turned off. See wiring diagrams on page 6 (top) and on page 8 for typical wiring.

FILTER PUMP: The function of this relay varies with the model of the Aqua Solar. If the "Solar Override" is enabled (see "Jumper Settings"), the Aqua Solar will **override** the time clock and turn the filter pump on when there is a call for solar heating. If "Recirculate Freeze" protection is enabled, the Aqua Solar will turn the pump and solar valve on during freezing conditions.

AQ-SOL-LV: This relay should be wired in parallel with the filter pump timeclock contacts as shown on page 6. Be careful to make sure the phases do not get reversed.

AQ-SOL-LV-TC: This relay is the primary control for the filter pump—there is no other timer. The Aqua Solar will operate the filter pump according to the "trippers" set on the built-in timeclock in addition to the optional "Solar Override" and "Recirculate Freeze" options.

AQ-SOL-LV

with Solar Override & Pool Sweep Interlock

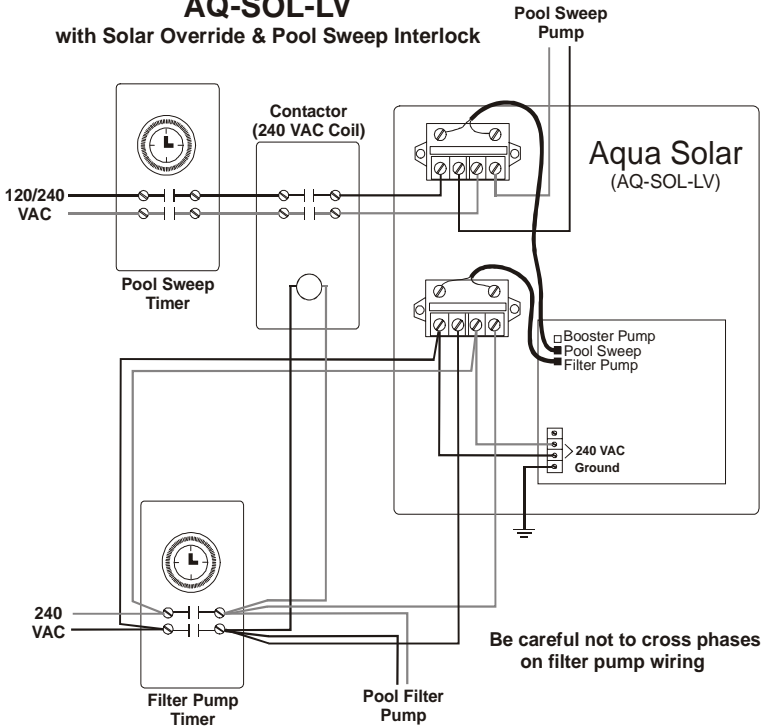

AQ-SOL-LV

with Solar Override & Boost Pump

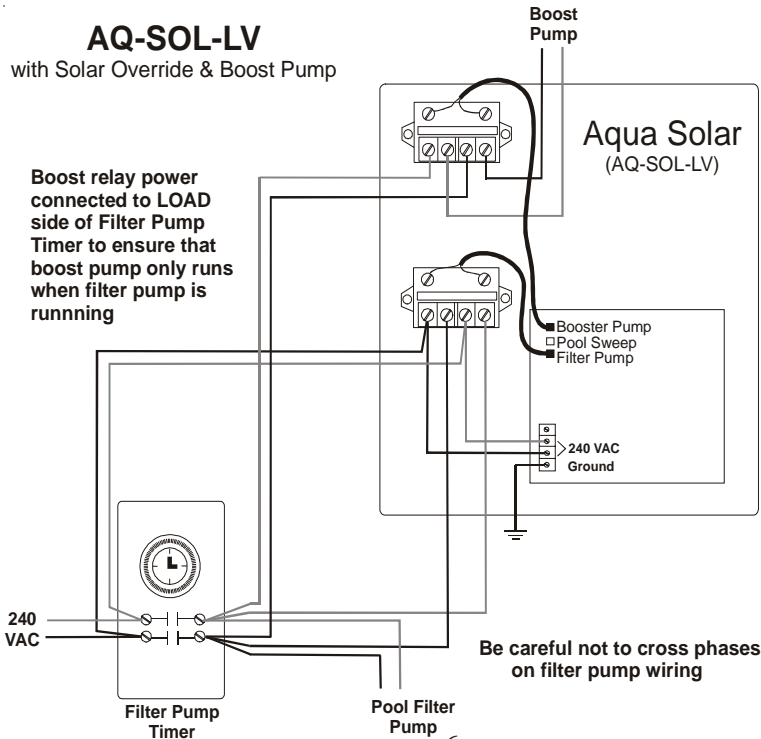

AQ-SOL-LV-TC

with filter pump & booster pump relays

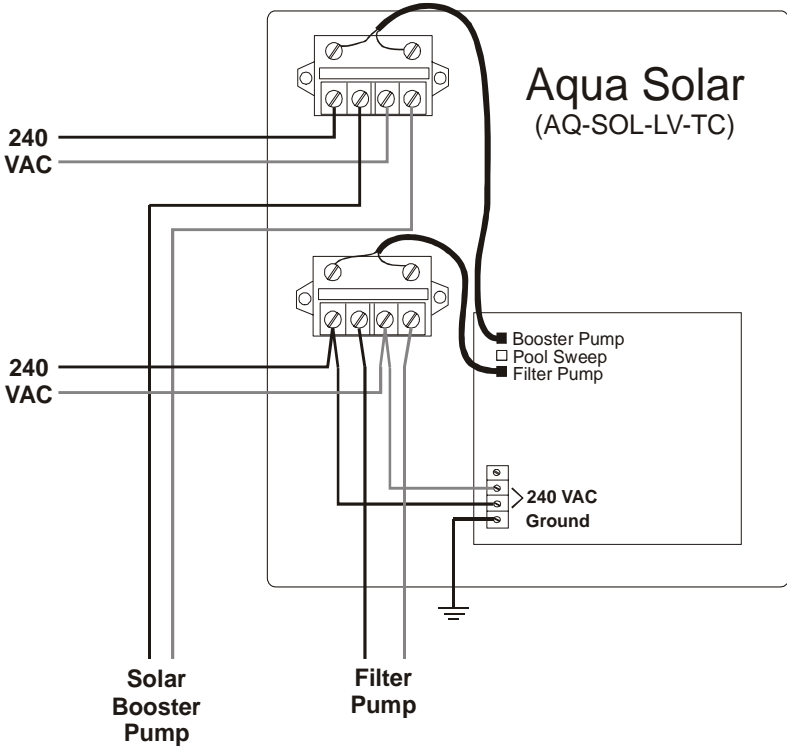

NOTES:

- 1) Do not use Aqua Solar terminal block as a junction for pump wiring.
- 2) Most codes require that each pump be on a separate circuit.

AQ-SOL-LV-TC

with filter pump & pool sweep relays

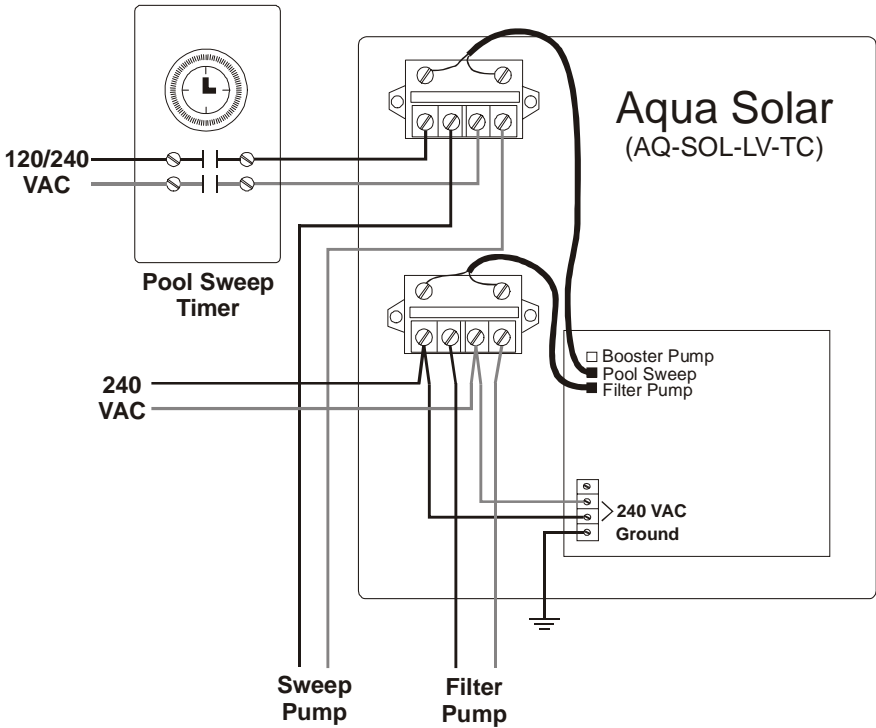

NOTES:

- 1) Do not use Aqua Solar terminal block as a junction for pump wiring.
- 2) Most codes require that each pump be on a separate circuit.
- 3) Aqua Solar will ensure sweep pump runs only when filter pump is running.
- 4) Sweep pump will turn off for approximately 5 minutes when solar turns on.

Jumper Settings

The jumpers that enable/disable optional control features are located on the right side of the main circuit board (see page 4). The factory default for all functions is "disabled" (each jumper will be on a single pin). To "enable" a function, simply take the designated jumper and place it over both pins.

COOLING: A high voltage relay for filter pump control is usually required to implement this function. If Cooling is enabled, the Aqua Solar will cool the pool by turning on the filter pump and diverting the flow through the collector array whenever the "POOL" temperature is WARMER than the "Desired Temperature" setting AND the "SOLAR" sensor is COOLER than the pool water.

RECIRCULATE FREEZE PROTECTION: A high voltage relay connected to the "FILTER PUMP" output and the AUX temperature sensor are required to implement this function. If enabled, the Aqua Solar will turn the filter pump on and operate the solar diverter valve whenever freezing conditions are detected (AUX sensor below 35°F). See diagram on page 6 for typical relay wiring. When recirculate freeze protection is enabled and the Aqua Solar senses a freeze condition at the AUX sensor, it will circulate the pool water continuously through the entire filtration plumbing loop including the solar collector panels. While this type of freeze protection is usually adequate in relatively mild climates, it is extremely important that the AUX sensor be properly placed and that the homeowner realize that the system is unprotected in the event of a power failure. Goldline Controls highly recommends that one or more "freeze snap switches" (models GC-1 or GC-2) be placed in areas with susceptible plumbing (example: areas that may be shaded, or get more wind exposure) and that these sensors be wired in series with the AUX sensor. **Recirculate freeze protection is NOT recommended in climates where freezing temperatures are common or last for extended periods.**

WARNING--If recirculate freeze protection is NOT selected, then you are relying on the collectors naturally draining to provide freeze protection. It is very important that you use a non-positive seal valve or drill a hole in the diverter of a positive seal valve to allow the collectors to drain. This will NOT work if the collectors are located below the water level of the pool.

CELSIUS DISPLAY: This will change the temperature display to degrees--Celsius. The factory default is degrees--Fahrenheit.

SOLAR OVERRIDE: A high voltage relay connected to the "FILTER PUMP" output is required to implement this function. When "Solar Override" is enabled, the Aqua Solar will **override** the filter pump timeclock (external timeclock for AQ-SOL-LV or internal timeclock for AQ-SOL-LV-TC) and turn the filter pump on whenever there is a call for solar heating or cooling. During periods of on/off cloudy days this may result in the pump turning on and off multiple times. It is also possible that the pump could turn on during hot night conditions. To prevent rapid on/off cycling of the filter pump during cloudy conditions, the pump will also remain on for a minimum of 10 minutes, and will remain off for a minimum of 2 hours.

Troubleshooting

1. "Power" LED off:

Check main power circuit breakers. Check to see if the Aqua Solar power is connected to the LOAD side of the filter pump timer, in which case the Aqua Solar will only be on when the filter pump is on. Lastly, check the internal fuse which is located on the right upper side of the main circuit board. If necessary, replace the fuse with a type 3AG, 2 amp, slo-blo fuse, which is available in most electrical or electronics stores.

2. "Heating" LED is always on:

Check that the switch is in the "AUTO" position. Check the sensor temperatures: The "Heating" LED should go off if the pool temperature is less than the "Desired Temperature" OR if the solar temperature is less than the pool temperature. If the sensors appear to giving incorrect readings, check the sensors using the temperature/resistance/voltage chart on the back cover.

3. "Heating" LED never comes on:

Verify that the switch is in the "AUTO" position. Check the sensor temperatures: The "Heating" LED should turn on when the pool temperature is less than the "Desired Temperature" AND the solar temperature is warmer than the pool temperature. The exception is when solar override is being used (typically when the pool is filtered at night, but the solar override function is used to turn the filter pump on during the day when solar heat is available): In this case, there is a 2 hour minimum off time to prevent rapid on/off cycling of the filter pump. If the sensors appear to giving incorrect readings, check the sensors using the temperature/resistance/voltage chart on the back cover.

4. "Heating" and "Cooling" LEDs on simultaneously

This indicates that the main switch is in the "ON" position. The Aqua Solar will operate the solar valve and the booster pump (if installed) regardless of the sensor temperatures. Set the switch back to "AUTO" to resume normal operation.

5. "Heating" and "Cooling" LEDs flashing simultaneously

This indicates that recirculate freeze protection is active (solar valve on, boost pump on (if used), and filter pump on) due to the "AUX" sensor being less than 35°F OR the "AUX" sensor being disconnected OR any freeze snap switches wired in series with the "AUX" sensor being open. If the "AUX" sensor is not connected OR a freeze snap switch is open, the "AUX" temperature display will be "LO". The Aqua Solar will continue this operating mode until the "AUX" sensor rises above 35°F AND all freeze snap switches wired in series with the "AUX" sensor are closed. This function operates regardless of the position of the "ON / AUTO / OFF" switch.

6. "Pool Sensor" LED on or flashing

"Err" on the pool temperature display:

On continuously indicates a probable open circuit in the "POOL" sensor or wiring. Flashing indicates a probable short circuit in the "POOL" sensor or wiring. In either case digital pool temperature display will show as "PErr". The solar heating and cooling functions will remain off until this problem is fixed, however, the recirculate freeze protection (if enabled by the jumper) will still operate properly. Use the chart on

the back cover to check the "POOL" sensor with a voltmeter (you don't need to disconnect the sensor). Alternatively, you can disconnect the sensor and measure the sensor resistance. Replace the sensor or fix the wiring as required. If the sensor and wiring are both good, then the main circuit PCB may have a problem.

7. "Solar Sensor" LED on or flashing

"Err" on the solar temperature display:

On continuously indicates a probable open circuit in the "SOLAR" sensor or wiring. Flashing indicates a probable short circuit in the "SOLAR" sensor or wiring. In either case digital pool temperature display for the "SOLAR" sensor will show as "CErr". The solar heating and cooling functions will remain off until this problem is fixed, however, the recirculate freeze protection (if enabled by the jumper) will still operate properly.

Use the chart on the back cover to check the "SOLAR" sensor with a voltmeter (you don't need to disconnect the sensor). Alternatively, you can disconnect the sensor and measure the sensor resistance. Replace the sensor or fix the wiring as required. If the sensor and wiring are both good, then the main circuit PCB may have a problem.

8. "Aux Sensor" LED flashing

"Err" on the Aux temperature display:

Flashing indicates a probable short circuit in the "AUX" sensor or wiring. The digital pool temperature display for the "AUX" sensor will show as "AErr". This error indication only occurs when the "AUX" sensor is being used for recirculate freeze protection. When the Aux sensor is shorted, the Aqua Solar will use the "SOLAR" sensor as a backup freeze sensor and turn the recirculate freeze protection on when the temperature is less than 60°F.

Use the chart on the back cover to check the "AUX" sensor with a voltmeter (you don't need to disconnect the sensor). Alternatively, you can disconnect the sensor and measure the sensor resistance. Replace the sensor or fix the wiring as required. If the sensor and wiring are both good, then the main circuit PCB may have a problem.

Technical Help

For help in installing, operating, or troubleshooting this control, you may call for technical assistance at 888-921-POOL (7665). Goldline technicians are available from 8AM to 8PM Eastern Time, Monday through Friday. You may call at other times and leave a message and a technician will call you back as soon as possible.

Limited Warranty - Solar Controls

11/1/2001

This warranty statement is applicable to all solar control products manufactured by Goldline Controls, Inc., previously known as Independent Energy, Inc. (Goldline) **on or after November 1, 2001**. See the appropriate warranty statement for other Goldline products or for solar controls produced prior to November 1, 2001.

Solar Controls installed in USA or Canada:

Goldline warrants its solar control products installed within the USA or Canada to be free from defects in material or workmanship, under normal use and service for **five years** from date of the initial system installation, provided it is installed in accordance with the Goldline installation instructions and specifications provided with the product. If written proof of the date of the initial system installation is not provided to Goldline, the manufacturing datecode on the product will be the sole determinant of the date of the initial system installation.

If a product is defective, in workmanship or materials and is removed and returned freight prepaid within three (3) years after the date of the initial system installation, Goldline Controls will, at its option, either repair or replace the defective product and return it freight prepaid. If the defective product is returned freight prepaid to Goldline more than three (3) years but within five (5) years of the date of the initial system installation, Goldline, at its option, will either repair or replace the defective product and will charge sixty percent (60%) of the current list price for such repairs or replacements, plus shipping charges. The costs incurred in removal and/or reinstallation of the product are NOT covered under this warranty.

Solar Controls installed outside of the USA or Canada:

Goldline warrants its solar control products installed outside of the USA or Canada to be free from defects in material or workmanship, under normal use and service for **one year** from date of the initial system installation, provided it is installed in accordance with the Goldline installation instructions and specifications provided with the product. If written proof of the date of the initial system installation is not provided to Goldline, the manufacturing datecode on the product will be the sole determinant of the date of the initial system installation.

If a product is defective, in workmanship or materials and is removed and returned freight prepaid within one (1) year after the date of the initial system installation, Goldline will, at its option, either repair or replace the defective product and return it freight prepaid. The costs incurred in removal and/or reinstallation of the product are NOT covered under this warranty.

Warranty exclusions:

1. Material supplied or workmanship performed by others in the process of installation
2. Damage resulting from improper installation or control of loads exceeding the product rating.
3. Problems resulting from failure to operate the products in accordance with recommended instructions contained in product's owners manual.
4. Problems resulting from tampering, accident, abuse, negligence, unauthorized repairs or alterations, fire, flood, lightning, freezing, external water, war, or acts of God.

THE EXPRESS LIMITED WARRANTY ABOVE CONSTITUTES THE ENTIRE WARRANTY OF GOLDLINE CONTROLS, INC. WITH RESPECT TO ITS SOLAR CONTROL PRODUCTS AND IS IN LIEU OF ALL OTHER WARRANTIES, EXPRESSED OR IMPLIED, INCLUDING WARRANTIES OF MERCHANTABILITY OR FITNESS FOR A PARTICULAR PURPOSE. IN NO EVENT SHALL GOLDLINE CONTROLS, INC. BE RESPONSIBLE FOR ANY CONSEQUENTIAL, SPECIAL OR INCIDENTAL DAMAGES OF ANY NATURE WHATSOEVER.

NO WHOLESALE, AGENT, DEALER, CONTRACTOR, OR OTHER PERSON IS AUTHORIZED TO GIVE ANY WARRANTY ON BEHALF OF GOLDLINE CONTROLS, INC. THIS WARRANTY IS VOID IF THE PRODUCT HAS BEEN ALTERED IN ANY WAY AFTER LEAVING THE FACTORY.

Temperature/Resistance /Voltage

All Goldline controls use a 10K thermistor sensors. When disconnected from the control, the sensor will read 10K ohms at 25°C/77°F. Refer to the chart below for the resistance at other temperatures. For a given temperature, the resistance reading should be accurate to $\pm 1\%$. For a given resistance reading, the temperature reading should be accurate to $\pm 0.5^\circ\text{F}$. All voltage measurements (DC) must be made with the sensor connected to the control and should be accurate to $\pm 2\%$.

°F	Ohms	Volts	°F	Ohms	Volts	°F	Ohms	Volts	°F	Ohms	Volts
1	82,719	4.46	41	25,391	3.59	81	9,076	2.38	121	3,679	1.34
2	80,142	4.45	42	24,704	3.56	82	8,861	2.35	122	3,602	1.32
3	77,656	4.43	43	24,037	3.53	83	8,651	2.32	123	3,527	1.30
4	75,255	4.41	44	23,391	3.50	84	8,447	2.29	124	3,454	1.28
5	72,937	4.40	45	22,764	3.47	85	8,249	2.26	125	3,382	1.26
6	70,698	4.38	46	22,156	3.45	86	8,056	2.23	126	3,312	1.24
7	68,535	4.36	47	21,566	3.42	87	7,867	2.20	127	3,244	1.22
8	66,447	4.35	48	20,993	3.39	88	7,684	2.17	128	3,177	1.21
9	64,428	4.33	49	20,438	3.36	89	7,506	2.14	129	3,112	1.19
10	62,479	4.31	50	19,900	3.33	90	7,333	2.12	130	3,049	1.17
11	60,595	4.29	51	19,377	3.30	91	7,164	2.09	131	2,987	1.15
12	58,774	4.27	52	18,870	3.27	92	6,999	2.06	132	2,926	1.13
13	57,014	4.25	53	18,377	3.24	93	6,839	2.03	133	2,867	1.11
14	55,313	4.23	54	17,899	3.21	94	6,683	2.00	134	2,809	1.10
15	53,669	4.21	55	17,435	3.18	95	6,530	1.98	135	2,752	1.08
16	52,078	4.19	56	16,985	3.15	96	6,382	1.95	136	2,697	1.06
17	50,541	4.17	57	16,548	3.12	97	6,238	1.92	137	2,643	1.05
18	49,054	4.15	58	16,123	3.09	98	6,097	1.89	138	2,591	1.03
19	47,616	4.13	59	15,711	3.06	99	5,960	1.87	139	2,539	1.01
20	46,225	4.11	60	15,310	3.02	100	5,827	1.84	140	2,489	1.00
21	44,879	4.09	61	14,921	2.99	101	5,697	1.81	141	2,440	0.98
22	43,577	4.07	62	14,543	2.96	102	5,570	1.79	142	2,392	0.97
23	42,318	4.04	63	14,176	2.93	103	5,446	1.76	143	2,345	0.95
24	41,099	4.02	64	13,820	2.90	104	5,326	1.74	144	2,299	0.93
25	39,919	4.00	65	13,473	2.87	105	5,208	1.71	145	2,254	0.92
26	38,777	3.97	66	13,136	2.84	106	5,094	1.69	146	2,210	0.90
27	37,671	3.95	67	12,809	2.81	107	4,982	1.66	147	2,167	0.89
28	36,601	3.93	68	12,491	2.78	108	4,873	1.64	148	2,125	0.88
29	35,565	3.90	69	12,182	2.75	109	4,767	1.61	149	2,084	0.86
30	34,561	3.88	70	11,882	2.72	110	4,664	1.59	150	2,044	0.85
31	33,590	3.85	71	11,589	2.68	111	4,563	1.57	151	2,005	0.84
32	32,648	3.83	72	11,305	2.65	112	4,464	1.54	152	1,966	0.82
33	31,737	3.80	73	11,029	2.62	113	4,368	1.52	153	1,929	0.81
34	30,853	3.78	74	10,761	2.59	114	4,274	1.50	154	1,892	0.80
35	29,998	3.75	75	10,500	2.56	115	4,183	1.47	155	1,856	0.78
36	29,169	3.72	76	10,246	2.53	116	4,094	1.45	156	1,821	0.77
37	28,365	3.70	77	9,999	2.50	117	4,007	1.43	157	1,787	0.76
38	27,587	3.67	78	9,758	2.47	118	3,922	1.41	158	1,753	0.75
39	26,832	3.64	79	9,525	2.44	119	3,839	1.39	159	1,720	0.73
40	26,100	3.61	80	9,297	2.41	120	3,758	1.37	160	1,688	0.72