

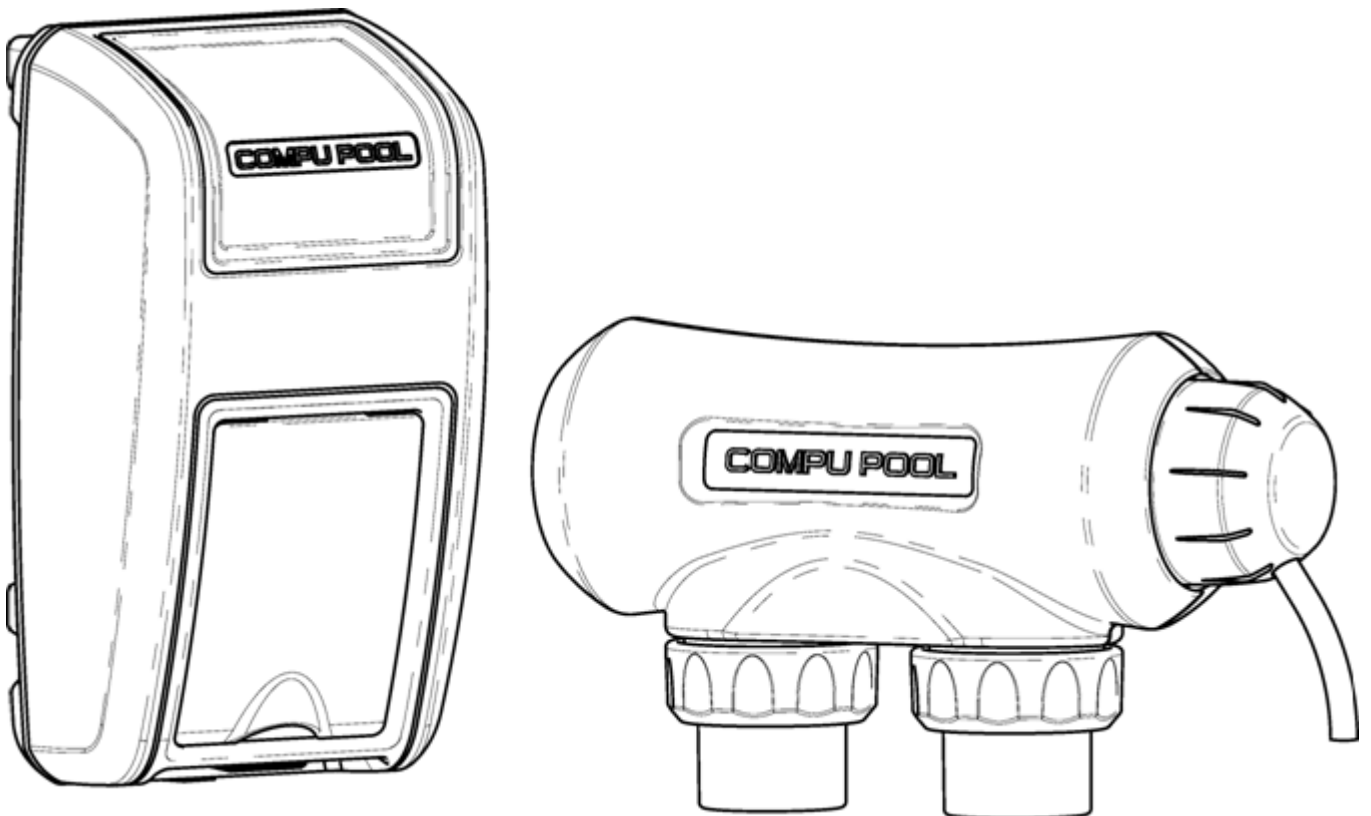

*'Technology in Harmony with Nature'*

## CPSC Series Saltwater Chlorine Generator Owner's Manual





*'Technology in Harmony with Nature'*

## CPSC Series Saltwater Chlorine Generator Owner's Manual

1.0	INTRODUCTION.....	3
2.0	GETTING STARTED .....	3
3.0	SAFETY INSTRUCTIONS .....	3
4.0	THE CHEMISTRY INVOLVED.....	4
5.0	WATER CHEMISTRY .....	4
6.0	ADDING SALT TO POOL OR SPA.....	7
7.0	INSTALLATION .....	9
8.0	INSTALLATION CHECKLIST.....	14
9.0	USING THE CONTROL PANEL.....	15
10.0	MAINTENANCE .....	17
11.0	TROUBLESHOOTING .....	19
12.0	WARRANTY.....	20

---

## 1.0 INTRODUCTION

- 1.1.1 Congratulations on your recent purchase of a Compu Pool Products CPSC Series Saltwater Chlorine Generator. Please take a moment to read through the entire manual before installing your new unit. Your generator must be installed and operated as specified.

## 2.0 GETTING STARTED

- 2.1.1 **READ THIS FIRST.** As with any electrical device it is very important that the installation and service of this equipment be performed by a qualified person with the skills and experience required to do it safely and correctly. Improper installation or service can result in severe electrical shock to the installer or user of the equipment or pool. Please choose your installer with great care.

## 3.0 SAFETY INSTRUCTIONS

### 3.1 IMPORTANT SAFETY INSTRUCTIONS, READ AND FOLLOW ALL INSTRUCTIONS. SAVE ALL INSTRUCTIONS.

- 3.1.1 **WARNING:** To reduce the risk of injury, do not permit children to operate this device.
- 3.1.2 **NOTE:** One bonding lug is provided on the external surface of the CPSC Series Chlorine Generator. Some local codes may require external grounding source. Check your local ordinances.
- 3.1.3 **WARNING:** Heavy pool (and/or spa) usage, and higher temperatures may require higher chlorine output to maintain proper free available chlorine residuals.
- 3.1.4 If additional chlorine is required due to heavy bather loads, use Sodium Hypochlorite to maintain an appropriate chlorine residual in the water. **NOTE:** For outdoor pools, chlorine residuals can be protected from destruction by sunlight by addition of stabilizer (cyanuric acid).
- 3.1.5 Maintaining high chlorine and very high salt levels above the recommended range can contribute to corrosion of pool (and/or spa) equipment.
- 3.1.6 The life of the electrolytic cell is 12,500 hours, under normal use conditions.
- 3.1.7 **DO NOT** add chemicals directly to the skimmer. This may damage the cell.
- 3.1.8 Check the expiration date of any test kits as test results may be inaccurate if used after that date.

- 
- 3.1.9 When replacing the cell, only use replacement cells having a label that clearly states that it is a replacement cell for this model.
  - 3.1.10 Follow all aspects of the local and National Electrical Code(s) when installing the CPSC Series Chlorine Generator.
  - 3.1.11 For proper sanitation, spas must be completely drained periodically. The number of days between COMPLETE SPA DRAINAGE is equal to the volume of the spa water in gallons, divided by 10 times the maximum number of daily spa users. Refill spa with water and repeat DIRECTIONS OF USE of this device.

## **3.2 Health and Hyperthermia warnings for spa devices**

- 3.2.1 People with a medical condition should consult a physician before entering pool or spa water.
- 3.2.2 Maximum spa water usage temperature is 104°F. Bathing time in spa water at 104°F should not exceed 15 minutes.

## **4.0 THE CHEMISTRY INVOLVED**

- 4.1.1 The CPSC Series Chlorine Generator by electrolysis creates chlorine to sanitize your pool using the salt molecules (NaCl) in your water. A small electric charge is applied across a set of titanium plates inside the Electrolytic Cell. This produces Sodium Hypochlorite (NaOCl). In water, Sodium Hypochlorite dissociates into sodium (NA+) and hypochlorite (OCI-) ions.
- 4.1.2 It is the hypochlorite ions that form with the hydrogen (H+) ions (from the water) to form hypochlorous acid (HOCl), which is the active agent that destroys bacteria and algae, and oxidizes organic matter. This form of chlorine works quickly in the pipe, leaving only a mild residual in the pool.

## **5.0 WATER CHEMISTRY**

- 5.1 **WARNING: Prior to turning on your CPSC Series Chlorine Generator for the first time (including reopening your pool for the new pool season) your water chemistry must be balanced according to the following guidelines.**

## 5.2 Recommended Salt and Pool / Spa Chemistry Readings

	Swimming Pools	Spas
<b>Free Available Chlorine</b>	1.0 – 3.0 ppm	3.0 – 5.0 ppm
<b>pH</b>	7.2 – 7.8	7.2 – 7.8
<b>Total Alkalinity</b>	100 – 120 ppm	100 – 120 ppm
<b>Calcium Hardness</b>	200 – 300 ppm	150 – 200 ppm
<b>Stabilizer (Cyanuric Acid)</b>	30 – 60 ppm	30 – 60 ppm
<b>Total Dissolved Solids</b>	< 1,200 ppm	< 1,200 ppm

- 5.2.1 **Chlorine Stabilizer (Cyanuric Acid).** Chlorine Stabilizer is needed to maintain proper levels of chlorine. Unstable chlorine can be destroyed by the sun's UV radiation within two hours. Chlorine stabilizer must be maintained between 30 – 60 ppm.
- 5.2.2 **Nitrates and Phosphates.** These chemicals can cause extremely high chlorine demands and will deplete chlorine from your pool. In some cases, they may even lower your chlorine levels to zero. Your local pool professional can test for Nitrates and Phosphates.
- 5.2.3 **Metals.** Metals can cause loss of chlorine. Also, metals can stain your pool and tint your water. Have your local pool professional check for metals and recommend methods of removal.
- 5.2.4 **Chloramines.** Chloramines should not be present in pool water. When organic materials are not fully oxidized by Free Chlorine, Chloramines are formed. This ties up the Free Chlorine in your pool, and does not allow the chlorine in your pool to disinfect. Chloramines also cloud pool water and burn the eyes. Shock the pool with chlorine to remove Chloramines at the initial startup of the pool.
- 5.2.5 **pH Levels.** pH produced by a chlorine generator is close to neutral pH. However, other factors usually cause the pH of the pool water to rise. Therefore, the pH in a pool chlorinated by a chlorine generator tends to stabilize at approximately 7.8. This is within national standards. If the pool pH rises above 7.8, have a pool professional test to see if other factors such as high Calcium Hardness or Total Alkalinity are the cause, and then balance accordingly.
- 5.2.6 **Total Dissolved Solids (TDS).** Adding salt to pool water will raise the TDS level. While this does not adversely affect the pool water chemistry or clarity, the pool water professional testing for TDS must be made aware that salt has been added for a chlorinator system. The individual performing the TDS test will then subtract the salinity level to arrive at the correct TDS level.

---

## 5.3 Water Chemistry Helpful Hints

- 5.3.1 Proper operation of the chlorine generator can be easily verified by inspecting the Electrolytic Cell. The chlorine being produced will appear as a fog at one end of the plates. However, if the pool remains cloudy, or the chlorine residual tests low, then the chlorine being produced is being lost due to high chlorine demand or improper water conditions.
- 5.3.2 To reduce the chlorine demand, check the pH and Stabilizer (Cyanuric Acid) reading. If tests show correct, then a shock treatment with an oxidizer agent is advised. Generally, superchlorination is not necessary if the pool is maintained at correct levels.

## 5.4 Recommended List

- 5.4.1 Read and keep your manual in a safe place.
- 5.4.2 Increase chlorine production when temperature goes up.
- 5.4.3 Increase chlorine production when number of guests go up.
- 5.4.4 Use Stabilizer (Cyanuric Acid) to protect free chlorine in pool
- 5.4.5 Mount Control Module in shade or out of the direct sunlight whenever possible.
- 5.4.6 Decrease chlorine production when temperature goes down.
- 5.4.7 Take pool water sample to a Pool Professional once per month.

## 5.5 Not Recommended List

- 5.5.1 Do not allow fertilizer anywhere near your pool. Fertilizers contain Nitrates or Phosphates which cause severe chlorine demand in pool water.
- 5.5.2 Never use dry acid to adjust pH. A build up of by-products can damage the Electrolytic Cell.
- 5.5.3 Do not add any pool water balancing chemicals (including salt) unless the Power Unit is turned off.
- 5.5.4 Do not add any chemicals (including salt) to the skimmers.
- 5.5.5 Do not let salinity level drop below 3000 ppm.

## 5.6 Definitions

- 5.6.1 **Algae.** Plant-like organisms which grow in water. Especially active in summer conditions, where chlorine disinfectant level is too low to destroy them. Algae may be green, yellow, brown or black (Black Spot) in color.
- 5.6.2 **Chlorine Demand.** The amount of chlorine that should be added to the water to provide proper bacteria and algae control.

- 
- 5.6.3 **Chlorine Residual.** The amount of chlorine left over, after the “demand” has been met.
  - 5.6.4 **Combined Chlorine.** Weak chlorine which is combined with the contaminants in the water.
  - 5.6.5 **Free Chlorine.** Active chlorine in the water with the potency to destroy contaminants.
  - 5.6.6 **Shock Treatment.** The removal by means of oxidation of those materials that have chlorine demand.
  - 5.6.7 **Superchlorination.** An extra large amount of chlorine added to the water.

## 6.0 ADDING SALT TO POOL OR SPA

### 6.1 Adding Salt

- 6.1.1 DO NOT add pool/spa chemicals directly to the skimmer. This may damage the cell. Maintaining high salt levels above the recommended range can contribute to corrosion of pool/spa equipment. If the chlorinator has already been installed, it must be turned off before adding salt. The recommended salt concentration for the CPSC Series is 3500 ppm.
- 6.1.2 For pools it is best to empty the required salt into the shallow end of the pool and run the filter and pump simultaneously while the CPSC Series chlorinator is off or in manual mode to circulate the water and dissolve the salt. Do not throw the salt bag into the pool or spa as chemicals and inks on the bag can interfere with the water balance.
- 6.1.3 Salt may take 24 – 48 hours to dissolve in the summer and longer in the winter. Finer granules of salt will dissolve faster than compressed pellets.

### 6.2 Type of Salt to Use

- 6.2.1 The purer the salt the better the life and performance of the electrolytic cell. Use a salt that is at least 99.8% pure NaCl. The preferred salt is an evaporated, granulated, food quality, non-iodized salt. Consult your local pool store.
- 6.2.2 Avoid using salt with anti-caking agents (sodium ferrocyanide, also known as YPS or yellow prussiate of soda) that could cause some discoloration of fittings and surface finishes in pool.
- 6.2.3 Water conditioning salt pellets are compressed forms of evaporated salt and may be used but will take longer to dissolve.
- 6.2.4 Do not use calcium chloride as a source of salt (use sodium chloride only).

---

6.2.5 Do not use Rock salt. Insoluble impurities mixed with the rock salt can shorten the life of the unit.

### 6.3 Salt Level

6.3.1 The Compu Pool CPSC Series chlorinator can work with a broad salinity range, from a minimum of 3000 ppm (parts per million), up to 6000 ppm. However, the ideal level for operation is 3500 ppm. To achieve this level of salinity, add 30 lbs. of salt for every 1000 gallons of water. If you are unsure of the number of gallons in your pool, double-check with the equations below.

	<b>Gallons (Measurements in Feet)</b>
<b>Rectangular</b>	Length x Width x Average Depth x 7.5
<b>Round</b>	Diameter x Diameter x Average Depth x 5.9
<b>Oval</b>	Length x Width x Average Depth x 6.7

6.3.2 The ideal salt level is 3500 ppm. If the salt level is low, determine the number of gallons in the pool and add salt according to the chart below. A low salt level will reduce efficiency of the chlorinator and result in low chlorine production. A high salt level can cause a salty taste to your pool. In addition, operating the unit outside the recommended salt range will rapidly reduce the longevity of the cell. The salt in your pool/spa is constantly recycled and the loss of salt throughout the swimming season should be small. This loss is due primarily to the addition of extra water to replace water lost from splashing, backwashing, and draining (because of rain). Salt is not lost due to evaporation.

6.3.3 If salt content is too high you will need to reduce the level of water in your pool/spa and refill the pool/spa with fresh water that has not been diluted with salt.

6.3.4 To initially start a pool with the correct amount of salt, add salt to the pool at a rate of 0.03 pounds of salt for every 1 gallon of water.



### Salt Level before addition (ppm)

		0	500	1000	1500	2000	2500	3000	3500
		How Much Salt to Add in pounds							
Volume of Water in thousands of gallons	4	117	100	83	67	50	33	17	0
	6	175	150	125	100	75	50	25	0
	8	234	200	167	133	100	67	33	0
	10	292	250	209	167	125	83	42	0
	12	350	300	250	200	150	100	50	0
	14	409	350	292	234	175	117	58	0
	16	467	400	334	267	200	133	67	0
	18	525	450	375	300	225	150	75	0
	20	584	500	417	334	250	167	83	0
	22	642	550	459	367	275	183	92	0
	24	701	600	500	400	300	200	100	0
	26	759	651	542	434	325	217	108	0
	28	817	701	584	467	350	234	117	0
	30	876	751	626	500	375	250	125	0
	32	934	801	667	534	400	267	133	0
	34	992	851	709	567	425	284	142	0
	36	1051	901	751	600	450	300	150	0
	38	1109	951	792	634	475	317	158	0
	40	1168	1001	834	667	500	334	167	0
	42	1226	1051	876	701	525	350	175	0
44	1284	1101	917	734	550	367	183	0	
46	1343	1151	959	767	575	384	192	0	
48	1401	1201	1001	801	600	400	200	0	
50	1460	1251	1043	834	626	417	209	0	

6.4.1 **Table 1 - Salt Table.** Locate the column that contains your pool's current salt concentration in parts per million at the top of the chart. Then locate the row that contains the size of your pool in gallons at the left of the chart. Where the column and row intersect within the chart is the number of pounds of salt required to be added to your pool.

## 7.0 INSTALLATION

### 7.1 Overview

7.1.1 The Power Unit is to be mounted at least 3 feet above ground level, and if possible protected from direct weather. The Electrolytic Cell is to be plumbed in the return line to the pool after the pump and filter (and heater, if applicable). Water flow through the cell can be in either direction, however ideal installation is horizontal, with the inlet and the outlet pointing down. The three cell lead connectors from the Power Unit are to be connected to the head of the cell.

---

## 7.2 Wiring

- 7.2.1 Power must be shut off at the circuit breaker before performing any wiring. Be sure to follow local and NEC electrical codes. The Compu Pool CPSC Series chlorinator has been designed to easily wire into typical in-ground pool systems. To provide safe operation, the unit must be properly grounded.
- 7.2.2 The Power Unit comes with a terminated power cord which is typically connected to an external timer, which will turn the pump and Power Unit on and off together. As all individual wiring set ups are unique, have the Power Unit wired to the load side of the external timer by a qualified person.
- 7.2.3 In Canada and in some parts of the United States, the Power Unit must be connected to a circuit protected by a Class A ground fault interrupter (GFI). Check local codes before connecting.
- 7.2.4 The Compu Pool CPSC Series is shipped from the factory with a 240 VAC configuration.

## 7.3 Changing the Wiring to 120 VAC

- 7.3.1 Power must be shut off at the circuit breaker.
- 7.3.2 Remove the six screws from the rear of the Power Unit.
- 7.3.3 Lift the housing cover off the backing plate.
- 7.3.4 Refer to Figure 1 for the 120 VAC configuration, moving only the wire on J12 to J11 and the wire on J8 to J14.
- 7.3.5 Ensure that the gray ribbon cable is secure at both ends.
- 7.3.6 Replace the housing cover. All wires must be enclosed within the housing so that they are not pinched between the housing cover and the backing plate.
- 7.3.7 Replace the six screws in the base of the Power Unit.

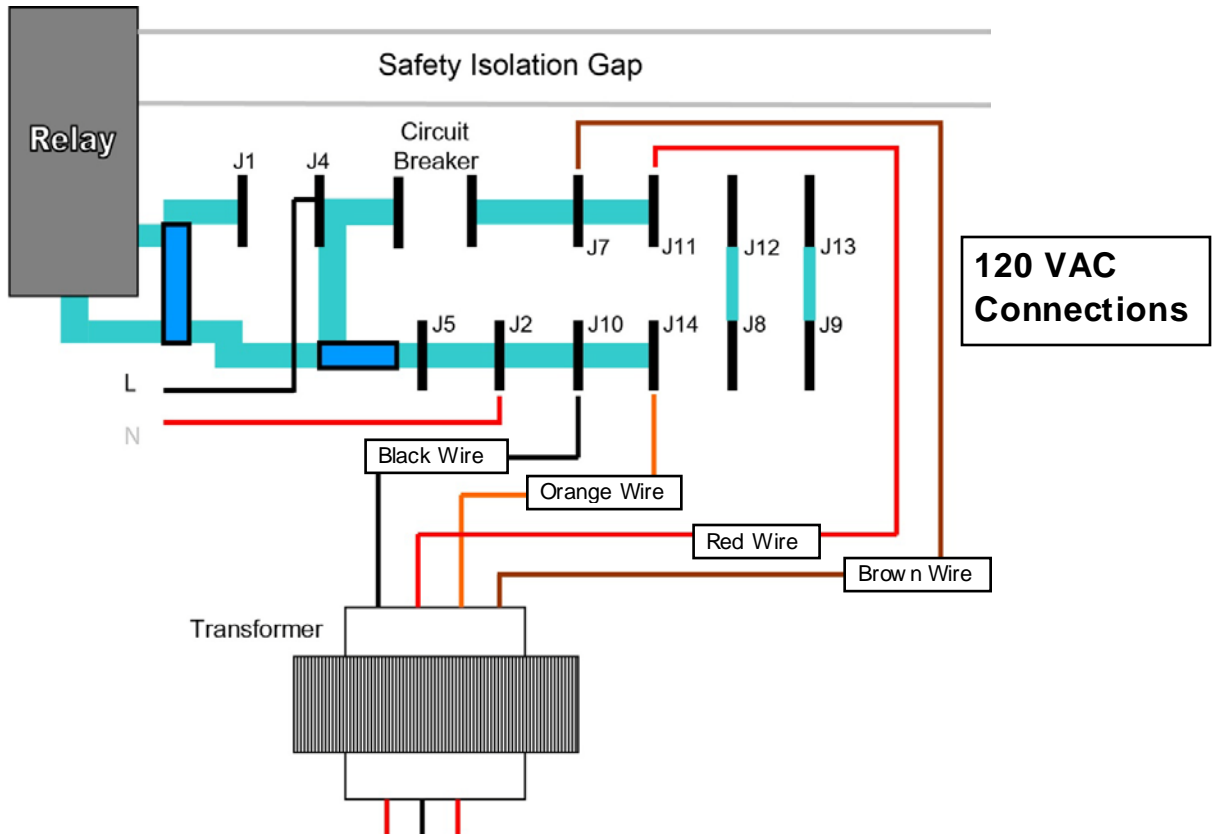

7.3.8 **Figure 1** - Internal Transformer Connections - 120 VAC Connections.

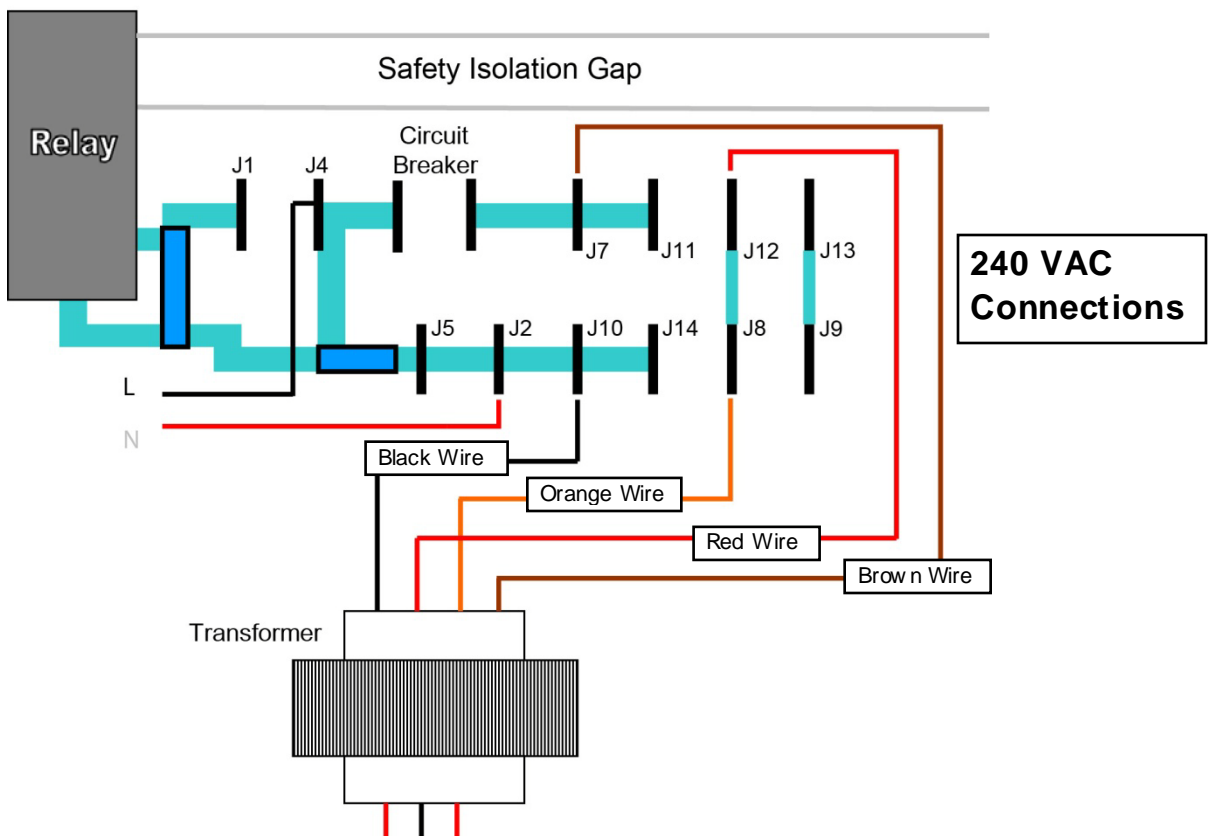

7.3.9 **Figure 2** - Internal Transformer Connections - 240VAC Connections.

---

## 7.4 Installing the Power Unit

- 7.4.1 Mount the Power Unit as close to the pump and filtration system as possible. Make sure the 6' DC cell power cord can reach the section of pipe selected for the cell. **Do not install the Power Unit within 10 feet of the pool edges.**
- 7.4.2 Using the provided screws and anchors, secure the mounting bracket at eye level. Once the mounting bracket is tightly secured, lift the Power Unit onto the mounting bracket and secure with the provided screws.
- 7.4.3 A lug for bonding is attached to the bottom of the Power Unit (see Figure 4). Connect to the pool bonding system using minimum 8 AWG copper wire if required by code.

## 7.5 Installing the Electrolytic Cell (Recommended Horizontal Installation)

- 7.5.1 Be sure the pool pump is turned off.
- 7.5.2 The cell is to be fitted into the return line to the pool after the pump, filter and heater (if applicable). Water flow should come from the filtration system through the socket marked "inlet" and back out through the hole marked "outlet".
- 7.5.3 Make sure that the 6 foot cell power cord reaches from the power unit to the area where you will be installing the cell. Compu Pool also has units available that come with 15 foot cell cords (must be requested at time of purchase).
- 7.5.4 Taking into consideration your existing plumbing, measure and cut the pipe before the last entry to the pool accordingly.
- 7.5.5 Install 90 degree elbows and vertical pipe to meet both the inlet and outlet barrel unions.
- 7.5.6 Position the cell on the vertical pipes (use pressure solvent cement to glue the piping to the barrel unions), making sure that the inlet and outlet are positioned correctly and that the cell is level.
- 7.5.7 Ensure the barrel union collar nuts are secured tightly to the cell housing.
- 7.5.8 Remove the Blue UV covers.
- 7.5.9 Connect the three cell lead connectors to the cell terminal posts as follows:
- Connect the red lead to the top terminal post
  - Connect the blue lead to the middle terminal post
  - Connect the black lead to the bottom terminal post
- 7.5.10 Slide the clear connector cap up the cell cord and position against the cell head.
- 7.5.11 Slide the collar nut over the clear connector cap and tighten.

7.5.12 Replace the Blue UV covers

7.5.13 NOTE: The cell measures 6 7/8" from the outside inlet barrel union to the outside outlet barrel union. The barrel union will accept 1 1/2" PVC to the inside and 2 " PVC to the outside.

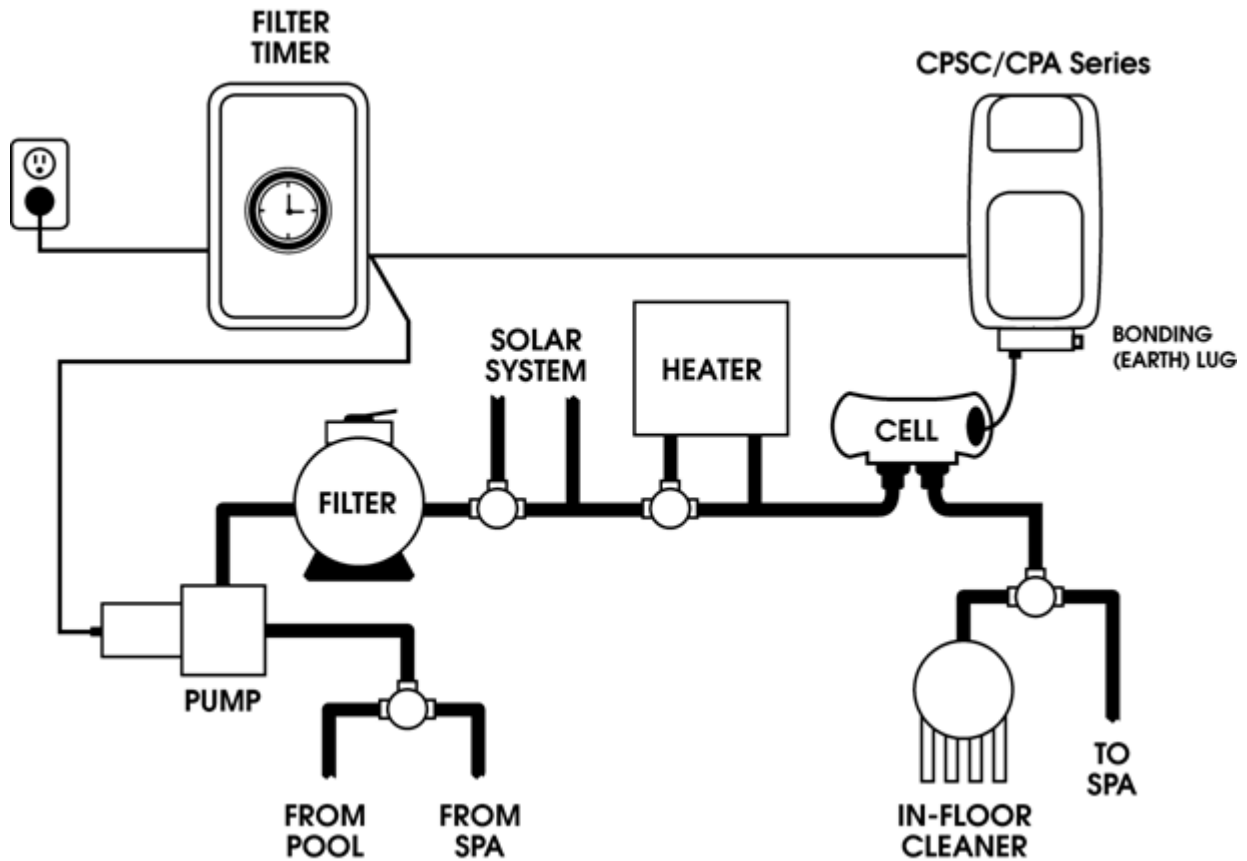

7.5.14 **Figure 3** - Installation Schematic.

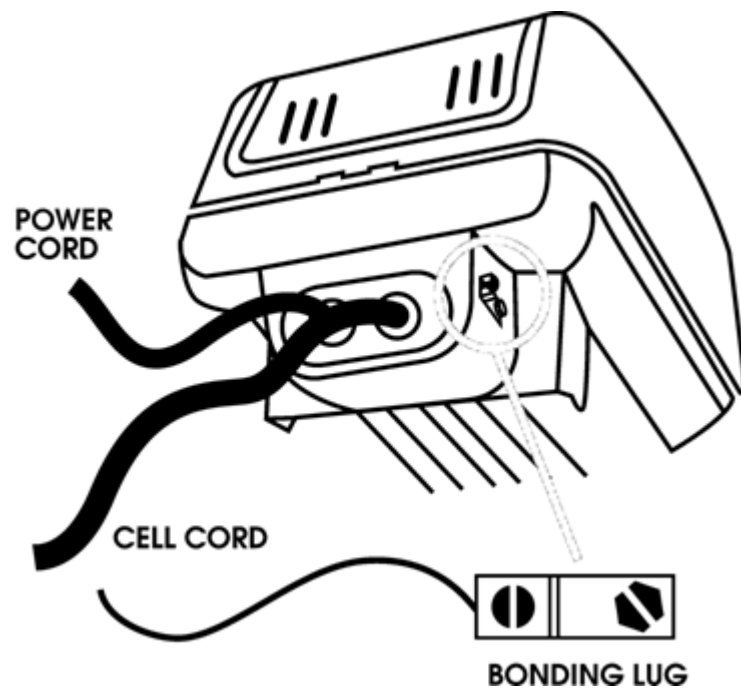

7.5.15 **Figure 4** - Bonding.

## 8.0 INSTALLATION CHECKLIST

- 8.1.1 Barrel unions installed and glued into pipe work
- 8.1.2 Barrel unions tightly connected into the cell housing.
- 8.1.3 Titanium blade assembly is tightly fitted into the clear cell housing.
- 8.1.4 The mounting bracket is securely affixed to wall or support.
- 8.1.5 The power unit is mounted in place to the metal backing bracket.
- 8.1.6 The power unit is connected to correct power source.
- 8.1.7 The cell cord from the Power Unit is connected to the cell.
- 8.1.8 Sufficient salt has previously been added and fully dissolved into pool water.
- 8.1.9 You have checked and confirmed that the Power Unit switches ON and OFF with the filter pump.
- 8.1.10 You have checked all connections and joints for leaks.

## 9.0 USING THE CONTROL PANEL

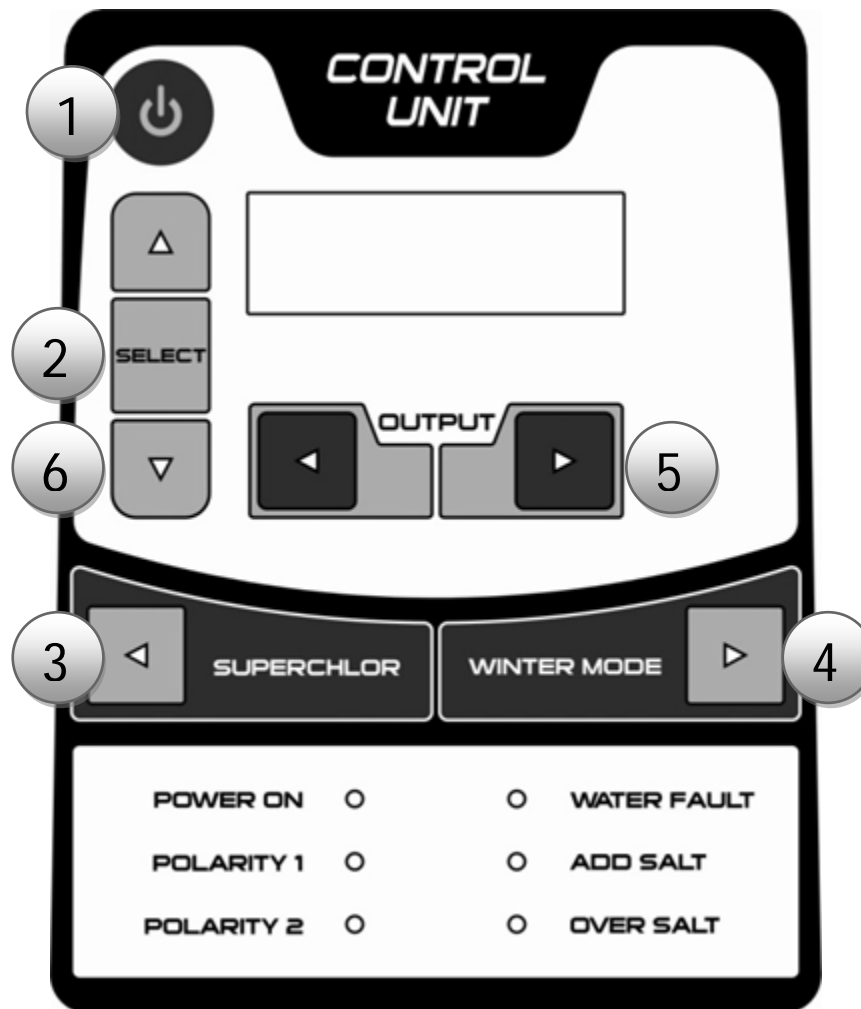

9.1.1 Note: Each time the unit is powered on, the LCD display will perform a 3 minute self-test, and then show the system's Time and Output Percentage.

### 9.2 Control Panel Buttons

1. **On / Off.** For normal operation, the system should be left in the "On" position. In this position the Compu Pool CPSC Series will produce chlorine according to the desired output %. Simply press the button again to turn the unit off.
2. **Select Button.** Holding this button in for 5 seconds will open the Timing/Readout menu that provides the following options:
  - a. Language (factory setting "English"): To change the language simply press the up or down arrow to scroll through the language options.
  - b. Which Timer (factory setting "Use External"): Use the down arrow to select "Use Internal".

- 
- c. **Set Clock:** When setting the clock time use the up and down arrow buttons to select the hour and minutes. Use the left and right arrow buttons to move the cursor between hour and minutes.
  - d. **Water Temp:** This displays an approximate water temperature.
  - e. **Salt Result:** This displays an approximate (10% variance) salinity concentration in ppm (parts per million). Note: Salt results can vary depending on water current and water temperature. It is recommended that a manual salt test is performed by a pool professional.
- 3. Super Chlor.** When you have an abnormally high bather load, a large amount of rain, a cloudy water condition which needs a large amount of purification to be introduced, simply press the SUPERCHLOR button. This electronically “super chlorinates” the water for 24 hours of physical run time. If the unit is turned off by pressing the On/Off button or if the SUPERCHLOR button is pressed again, the unit will return to normal operation.
- 4. Winter Mode.** When you are not using your pool during the winter months, it is advisable to activate the winter mode. Simply press the WINTER MODE button. The Winter Mode will reduce the output of chlorine to 50% of the set chlorine output. For example: If chlorine output is set to 80%, it will change to 40% when the WINTER MODE button is pressed. To deactivate winter mode, simply press the WINTER MODE button. Note: Reducing the chlorine output during periods when the pool is not in use will help maximize the life of the cell.
- 5. Output.** Pressing left or right arrow buttons will change the CHLORINE PRODUCTION output in 10% increments. NOTE: When initially starting up your CPSC Series Chlorine Generator it is recommended that the output be set at 100%, decreasing in 10% increments ensuring that the unit is maintaining the appropriate chlorine level in your pool/spa.
- 6. Up and Down Arrows.** Pressing the Up or Down arrow will enable navigation through the menu options.

## 9.3 Control Panel LED Indicators

- 9.3.1 **Power On.** When illuminated, the CPSC Series unit has input power activated.
- 9.3.2 **Polarity 1 & 2.** One Polarity LED at a time will be illuminated indicating which operation cycle the unit is on. The system automatically switches polarities in order to inhibit the buildup of calcium and other minerals on the cell as part of the self-cleaning feature.
- 9.3.3 **Water Fault.** When illuminated, the flow sensor has detected no water flowing. The display will read “No Flow”. The system will have stopped producing chlorine as a safety measure. Severe low salt conditions will also activate the “Water Fault” warning light.



- 
- 9.3.4 **Add Salt.** The Compu Pool CPSC Series will automatically let you know if the salinity concentration has fallen below acceptable levels. When illuminated for more than two hours, add more salt as needed. The amount required varies with pool size. Refer to Table 1 to determine additional amount of salt needed.
- 9.3.5 **Over Salt.** When illuminated, the salt content is more than sufficient. The CPSC Series has a built-in regulating system that enables it to continue to produce chlorine with the increased salt content. At this point do not add any further salt and allow the salt content to return to desirable levels.

## 10.0 MAINTENANCE

### 10.1 Water Chemistry

- 10.1.1 It is recommended that a pool water sample be taken to a Pool Professional once per month for analysis. Please refer to the section entitled "Water Chemistry" for additional information.

### 10.2 Electrolytic Cell

- 10.2.1 The cell operates most efficiently when it is clean. As a natural result of the electrolytic process which creates chlorine from salt molecules, calcium build up is attracted to the titanium plates in the cell. The self-cleaning feature helps to inhibit such build up and scaling. However, the attraction of calcium and other minerals is inevitable and eventually it must be removed. The cell only needs cleaning to ensure that build up does not cause individual plates to come in contact with each other. The clear housing of the cell allows easy visual inspections, and with correct water chemistry, the cell will only need cleaning once or twice a season (about every 6 months).

### 10.3 Removing the Cell for Cleaning

- 10.3.1 Turn off all power and close return line valves, if applicable.
- 10.3.2 Remove the Blue UV covers.
- 10.3.3 Remove the collar nut from the cell head, releasing the clear cap that houses the cell lead connections.
- 10.3.4 Disconnect the three cell lead connections from the cell terminal posts.
- 10.3.5 Pull entire cell away from the cell housing.

### 10.4 Cleaning the Cell

- 10.4.1 With the cell removed use a high pressure hose nozzle to spray off as much loose scale and debris as possible. Use a plastic or wooden tool to remove deposits off the plates.

- 
- 10.4.2 Do not use any sharp or metallic objects to remove scale. Scraping or scratching the cell plate's edge or surface will allow chemical attack of the plate, cause premature failure of the cell and will void the warranty.
  - 10.4.3 If further cleaning is required the cell needs to be cleaned in a mixture of one (1) part Hydrochloric (Muriatic) Acid into four (4) parts water (always add acid to the water). When using the acid ensure to use rubber gloves and appropriate eye protection.
  - 10.4.4 Mix the acid and water in a bucket and place the cell into the bucket. Ensure that the acid fill line is below the cell head area, submerging of this area will damage the cells electronics and void the warranty.
  - 10.4.5 Clean the cell until the foaming action stops (typically 5 to 10 minutes). Rinse the cell with fresh water and re-install into the plumbing line.
  - 10.4.6 Note: Excessive cleaning will reduce the lifespan of the cell.

## **10.5 Winterizing the Cell**

- 10.5.1 The Electrolytic Cell will be damaged by freezing water just as your pool plumbing would. In areas which experience severe or extended periods of freezing temperatures, be sure to drain all water from the pump, filter, supply and return lines before any freezing conditions occur. The Power Unit is capable of withstanding any winter weather and does not need to be removed.

## **10.6 Replacing the Cell**

- 10.6.1 When the titanium blades inside the Electrolytic Cell have reached the end of their lifespan, replacements are available so that the whole system does not have to be removed. Replacements are easily switched out. To ensure quality and value, only genuine Compu Pool replacement parts may be used.

## **10.7 Removing the Cell for Replacement**

- 10.7.1 Turn all AC power off.
- 10.7.2 Remove the Blue UV covers.
- 10.7.3 Remove the collar nut from the cell head, releasing the clear cap that houses the cell lead connections.
- 10.7.4 Disconnect the three cell lead connections from the cell terminal posts.
- 10.7.5 Remove the cell from the clear housing.

---

## 11.0 TROUBLESHOOTING

### 11.1 Power LED and LCD Screen Not Turning On

11.1.1 Check to make sure either 120 VAC or 240 VAC input power is connected to the proper screw terminals at the control. Verify input voltage with a voltmeter. If there is input power, the circuit breaker may have tripped. The CPSC Series is protected by a 5 amp circuit breaker located at the base of the power pack. To reset the circuit breaker press the small yellow pin back in. Main power to the unit must be turned off prior to resetting the circuit breaker. Should the circuit breaker continue to trip after this exercise then you should consult Compu Pool for assistance.

### 11.2 Water Fault LED Illuminated

11.2.1 The power unit has sensed a no-flow condition and has stopped generating chlorine. Check that there is water in the cell enclosure. If there is adequate flow and the LED is still on, determine if salt has been added to the pool. If no salt has been added, the no flow light will be illuminated. If the LED is still illuminated check the connection between the cell plug connectors and the brass cell terminal posts.

### 11.3 Low or No Chlorine Residual

11.3.1 The possible cause may be one or more of the following:

- Insufficient chlorine output %
- Insufficient running times
- Insufficient or excessive stabilizer
- pH too high
- Salt content below 2500 ppm
- Check wire connections
- Check circuit breaker on Power Unit
- Check that filter pump running
- Check that water flow through Cell is sufficient
- Cell needs cleaning

### 11.4 Water Flow Through Cell is Low

11.4.1 The possible cause may be one or more of the following:

- Check for air in system
- Check operation of pump
- Check filter is clean
- Check water level in pool
- Check for blockage in skimmers and/or plumbing

---

## 12.0 WARRANTY

### 12.1 Warranty Terms

- 12.1.1 Compu Pool CPSC Series chlorine generators carry the following **three year warranty** should fault occur due to faulty manufacturing or materials.
- 12.1.2 For residential use, Compu Pool warrants the original purchaser that the equipment shall be free of manufacturer defects at the time of sale and upon examination, shall provide replacement parts or repair in accordance with the following schedule:
- 12.1.3 **First 60 Days.** Parts supplied at no cost.
- 12.1.4 **First Year.** Parts supplied from our facility or returned for repair to our facility at no cost. Compu Pool reserves the right to determine whether or not a part will be replaced with a new or refurbished part or repaired.
- 12.1.5 **Second Year.** Parts supplied from our facility or returned for repair to our facility at no cost. Compu Pool reserves the right to determine whether or not a part will be replaced with a new or refurbished part or repaired.
- 12.1.6 **Third Year.** Parts supplied from our facility or returned for repair to our facility at 66% of normal cost of parts and repair labor. Compu Pool will cover the cost of return freight only.
- 12.1.7 For Commercial use in any “regulated pool”, all parts are warranted against defect for a period of one year, without pro-ration.

### 12.2 Void Warranty

- 12.2.1 The warranty may be void if the following occurs:
- 12.2.2 Damage to the unit beyond Compu Pool's control.
- 12.2.3 Damage due to improper pool chemistry.
- 12.2.4 Damage due to improper installation.
- 12.2.5 Damage due to failure to properly maintain unit.
- 12.2.6 Damage due to improper service.
- 12.2.7 Damage caused by insects or natural elements.

### 12.3 Warranty Coverage

- 12.3.1 This warranty is applicable to workmanship and materials only and Compu Pool, its agents, employees, and affiliates expressly disclaim responsibility for loss, damage, or injuries to persons or property arising from warranty failure, or installation of equipment. Warranty claims must be initiated in a timely manner by calling (888) 989-SALT.

---

## 12.4 Customer Warranty Information

12.4.1 Please complete the information below at time of installation and retain in the event you need to file a warranty claim

Model Number	
Voltage (240v or 120v)	
Pump Socket (Yes or No)	
Power Unit Serial Number	
Cell Serial Number	
Purchase Date	
Purchased From	
Installation Date	
Installer	