



SAND FILTERS

HIGH SPEED FILTERING

INSTALLATION AND MAINTENANCE MANUAL

The manual of 20" Platinum Super-Flow Sand Filter Pump System

MODELS:

75032 (Dia. 20inch filtering)

SAFETY INFORMATION

1. The sand filters are designed to work with water at temperature >than 0 °C and <than 45 °C .The filter should never be operated outside of these temperatures or damage may occur.
2. The installation should be carried out in accordance to the safety instructions of swimming pools and the specific instructions for each facility
3. The user should make sure that the installation is carried out by qualified authorized persons and that these persons have first carefully read the following instructions. Incorrectly installed equipment may fail, causing severe injury or property damage
4. The operating safety of the filter is only guaranteed if the installation and operation instructions are correctly followed.
5. To reduce the risk of injury, do not permit children to use this product.
6. Chemical spills and fumes can weaken Swimming Pool/ Spa. Corrosion can cause filters and other equipment to fail, resulting in severe injury or property damage. Do not store pool chemicals near your equipment.
7. Any modification of the filter requires the prior consent from the supplier's original replacement parts and accessories authorized by the manufacturer ensure a high level of safety. The supplier assumes no liability for the damage and injuries caused by unauthorized replacement parts and accessories.
8. In the event of defective operation or fault, contact the supplier or its nearest authorized service agent

Sand Filtration system working principle

Incoming water from the piping system is automatically directed by the Multiport Valve to the top of the filter bed. As the water is pumped through the filter sand, dirt and debris are trapped by the filter bed, and filtered out. The filtered water is returned from the bottom of the filter tank, through the Multiport Valve and back through the piping system.

Sand Filtration system working principle

1. Position the filter as close to the Swimming Pool/ Spa as possible.
2. The filter should be placed on a level concrete slab, very firm ground, or equivalent. Ensure that the ground will not subside, preventing any strain from the attached plumbing.
3. Position the filter under consideration of the piping connections, so that it is convenient for operating and servicing.
4. Ensure that the compliance label is facing the front to allow easy identification in the case of service difficulties.

How to install the filter tank

INSTALLATION

1. Mount the pump to sand filter support by using bolts and nuts.

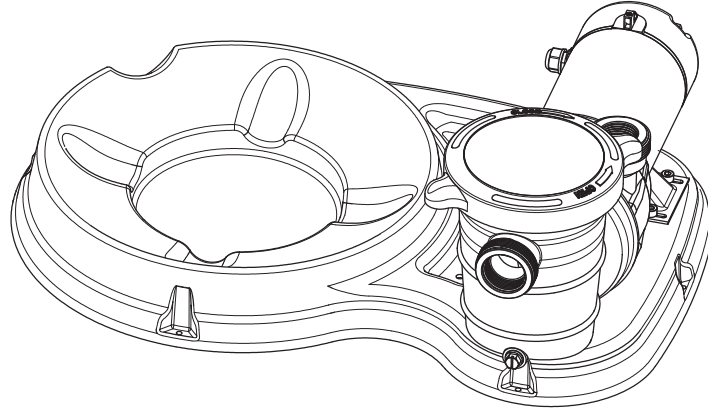

2. Place the tank onto sand filter support with correction direction (drain plug is at outside as below picture).

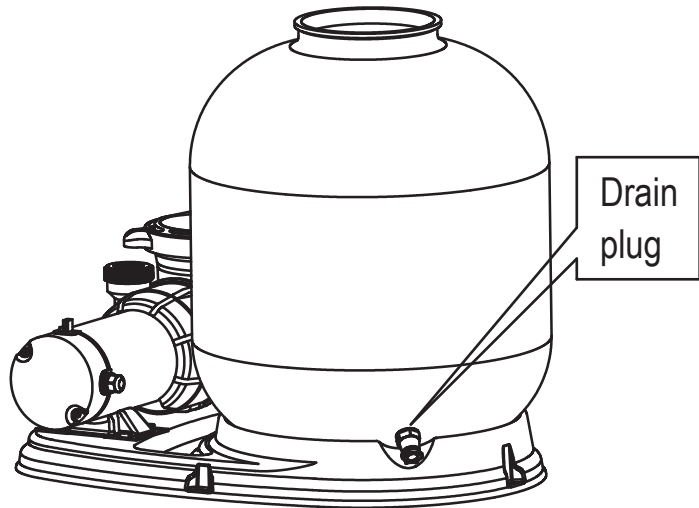
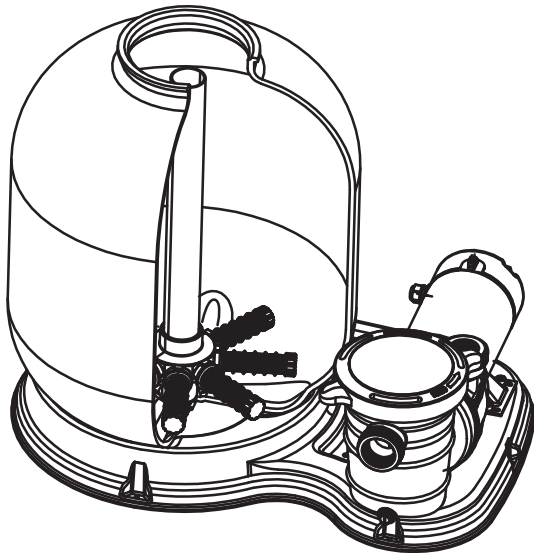

3. Insert the tube with the diffuser body inside the tank as above picture, then place the funnel on the tank's mouth and pour the quartz sand into the tank (sand weight 85kg).

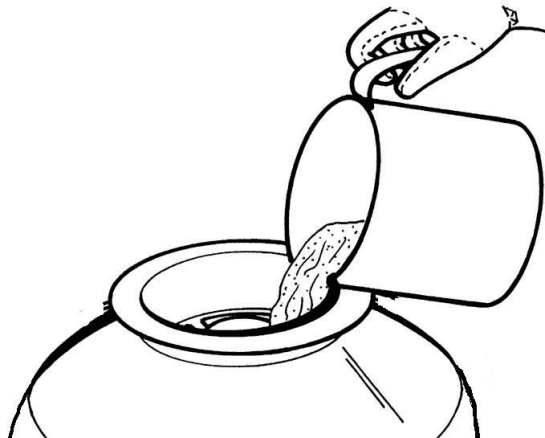
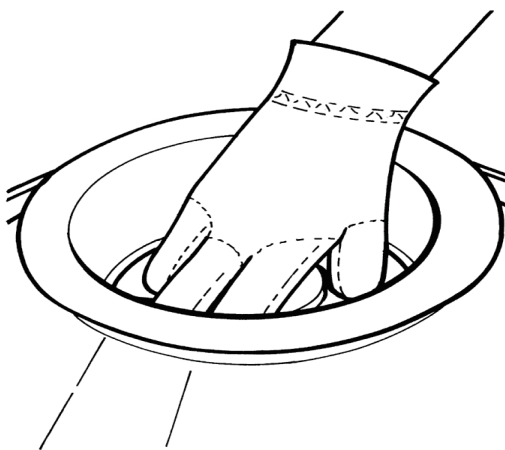

4. Take away the funnel, and then clean really carefully the tank's neck and fix the valve with O-ring through flange clamp set. (the direction of "PUMP" port on valve needs to face pump out port)

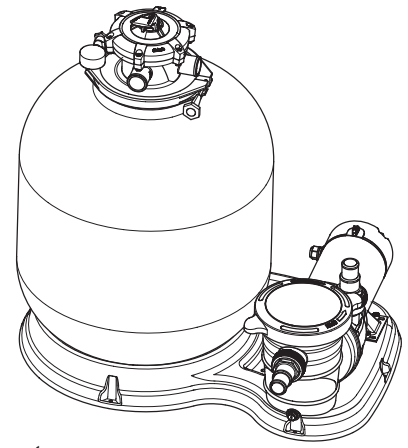
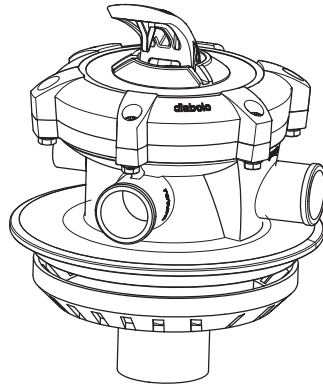
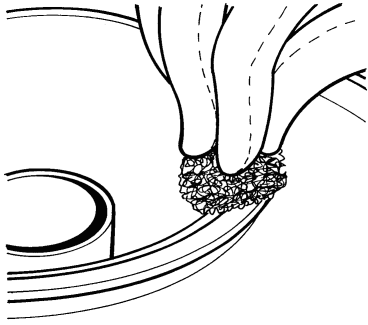

5. Connect the sand tank to pump with hose, hose clamps and hose adaptors.

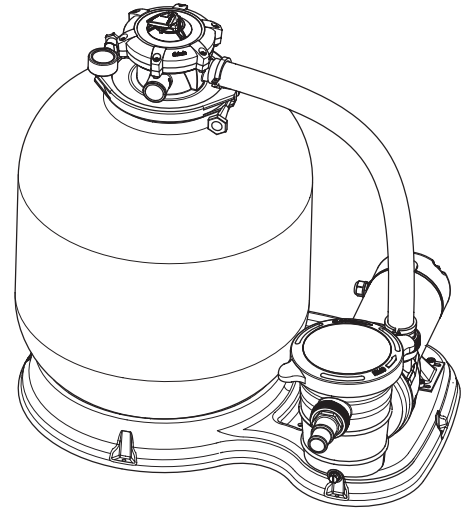
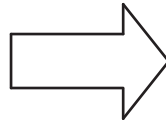
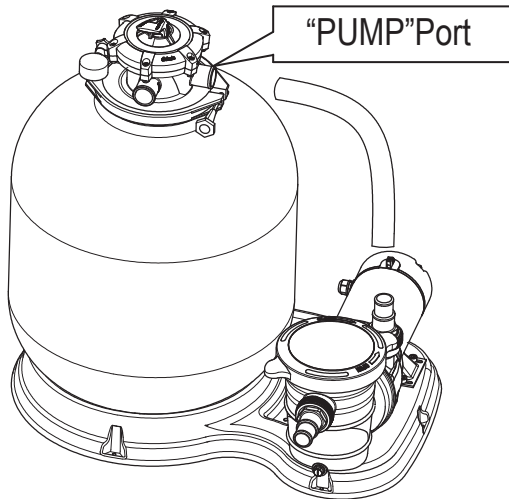

INSTALLATION NOTES:

1. Make sure the filter is worked under the work pressure, and using a pressure control valve when the system using a booster pump.
2. If the pump position is higher than the water level, it requires to install the back water control valve.
3. If the pump position is lower than the water level, it requires installing an isolation valve. It could stop the water return back when people do the general inspection.
4. Reducing the connect adaptors and hose connecting bending as less as possible. Decreasing the water flow scrub, it could reach the maximum effective.
5. Ensure solvents are not excessively applied to fittings as this could run into O-ring and create sealing problems.
6. Do not over tighten fittings or adaptors

HOW TO USE

1. Inspect all the connections have been made correct and are secure.
2. Depress top mount valve handle and rotate to BACKWASH position.
3. Prime and start pump according to pump instructions.

NOTE: ALL SUCTION AND DISCHARGE VALVES MUST BE OPENING WHEN STARTING THE SYSTEM. FAILURE TO DO SO COULD CAUSE SEVERE PERSONAL INJURY.

MAKE SURE THE FILTER VESSEL ARE FULL FILL THE WATER BEFORE START UP THE PUMP. OR IT WILL CAUSE THE PUMP DAMAGED.

4. Once water flow is steady out the waste line, run the pump for at least 2 minutes. The initial back-washing of the filter is recommended to remove any impurities of fine sand particles in the sand media.
5. Turn pump off and set valve to RINSE position. Start pump and operate until water in sight glass is clear ---about 1/2 to 1 minute. Turn pump off, set valve to FILTER position and restart pump. Your filter is now operating in the normal filter mode, filtering particles from the pool water.

NOTES:

1. Note the initial pressure gauge reading when the filter is clean. (it will vary from pool depending upon the pump and general piping system). As the filter removes dirt and impurities from the pool water, the accumulation in the filter will cause the pressure to rise and flow to diminish. When the pressure gauge reading is 8-10 PSI(0.55-0.69 BAR) higher than the initial "clean" pressure you noted, it is the time to backwash (clean) the filter.
2. **IMPORTANT:** To prevent unnecessary strain on piping system and valving, always shut off pump before switching filter control valve position.
3. To prevent damage to the pump and filter and for proper operation of the system, clean pump strainer and skimmer baskets regularly.

FILTER CONTROL VALVE FUNCTIONS :

FILTER - Set valve to FILTER for normal filtering. Also use for regular vacuuming.

BACKWASH - For cleaning filter. When filter pressure gauge rises 8-10 PSI (0.55-0.69 BAR) above start-up (clean pressure):

Stop the pump, set valve to BACKWASH. Start pump and backwash until water in sight glass is clear. Approximately 2 minutes or less depending on dirt accumulation. Proceed to RINSE.

RINSE - After backwashing, with pump off, set valve to RINSE. Start pump and operate for about 1/2 to 1 minute. This ensures that all dirty water from backwashing is rinsed out of the filter to waste, preventing possible return to the pool. Stop pump, set valve to FILTER and start pump for normal filtering.

WASTE - To bypass filter for draining or lowering water level and for vacuuming heavy debris directly to waste.

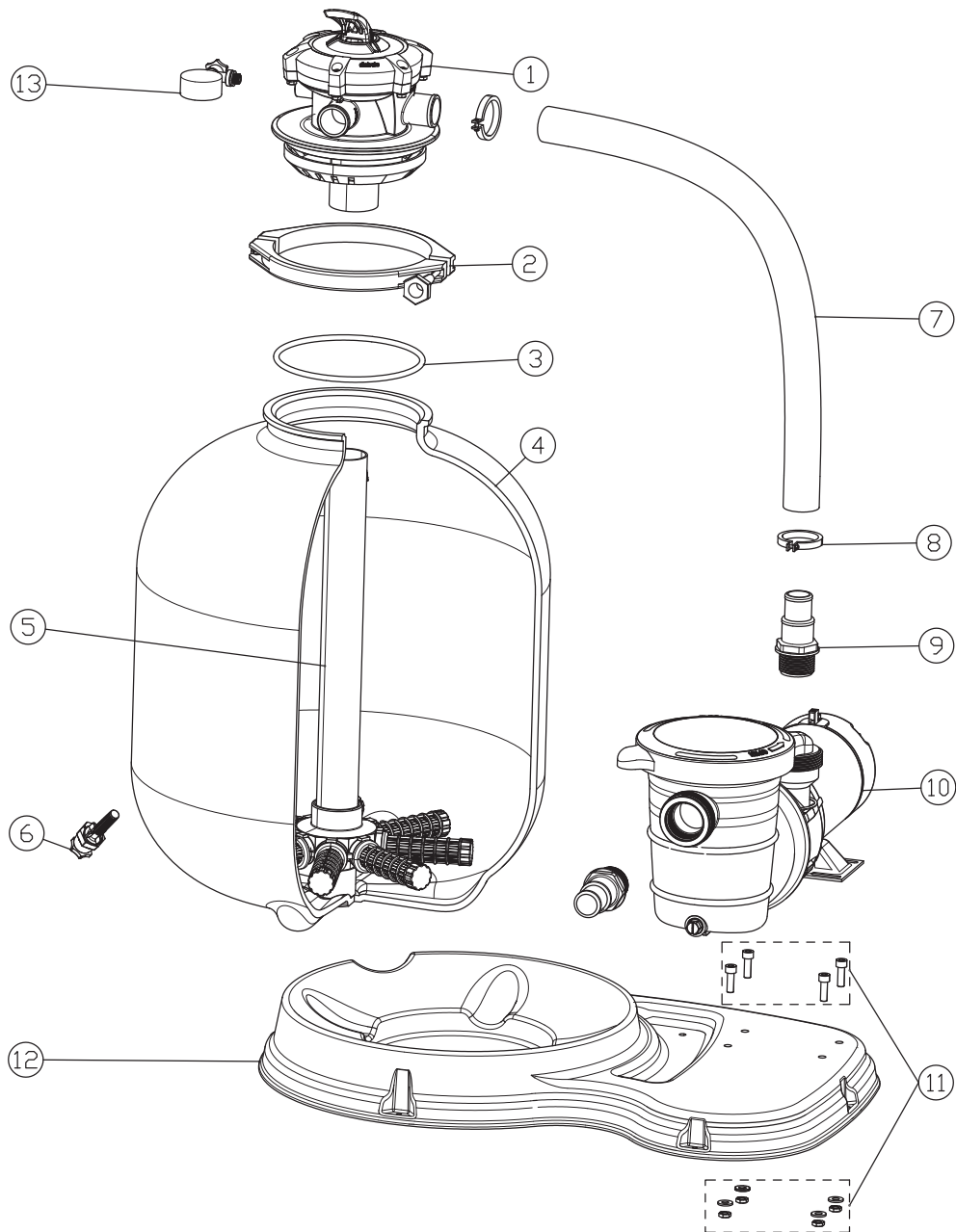

Parts Listing

No.	Description	quantity
1	1.25"top valve	1
2	Clamp assembly	1
3	O ring	1
4	Dia.500 sand tank	1
5	Diffusor assembly	1
6	Drain plug	1
7	Dia.38*720mm PVC pipe	1
8	Hose clamp	2
9	Hose adaptor	2
10	1HP STARK pump	1
11	Nut and bolt	4
12	Sand filter support	1
13	Gauge assembly	1

TROUBLESHOOTING AND TECHNICAL SERVICE

This filter and its instructions are designed for domestic use, with no need for professional supervision, except for exceptional cases. Here we shall describe the problems and causes which may arise after years of service of the filter that you can repair yourself. If you cannot solve the problem, contact the pool manufacturer at the telephone indicated in the instructions.

PROBLEM	CAUSE	SOLUTION
The filter leaks through the hose terminals	Improper connection between the terminals and the hoses.	Place Teflon in the housings. Insert the hose terminals up until the bottom of the housing and tighten the clamps.
After the filter has started up, there is no flow in the feedback nozzle.	The valve is not on the filtration setting.	Disconnect the filter and place the valve on the correct setting.
	The filter is above the level of the unprimed water.	Place the filter in the correct position and prime it.
	The suction cover or the skimmer plug have been inserted.	Remove the suction cover or the skimmer plug.
Intermittent operation	Low water level on skimmer	Fill the pool and prime the filter.
	The filter is not primed.	Prime the filter.
The flow rate of the filter is low.	Due to use, the filter is dirty.	Perform a backwash.
	The filter is not primed.	Prime the filter.
Water comes out through the filter opening.	The connection between the valve and the filter is dirty.	Clean the sand from the opening. Insert the coupling on the valve properly and tighten the metal band firmly.
	Metal band is loose.	
The filter valve leaks through the drain terminal.	Inner coupling damaged due to improper use of chemical product.	Change the top valve cover. Do not put chemical products in the preliminary filtration skimmer basket.
	Valve head broken due to improper use. (over tightening)	Change the valve head. Do not over tighten.
The motor will not start up. There is no noise or vibration.	No current in the electric line.	Check that there is current in the electric line.
The motor does not start up but a buzzing sound can be heard.	Motor damaged	Contact the After-Sales Service of the pool manufacturer.
Water leakage.	Find out where the water is leaking.	Check the hose clamps.
		If the leak is between the pump and the motor, contact the After-Sales Service of the pool manufacturer.